

Structure and Reactivity

Fall Semester 2025

Lecture Notes

Prof. Nicolai Cramer
BCH 4305
nicolai.cramer@epfl.ch

Assistant:
Andrea Brugnetti
andrea.brugnetti@epfl.ch

Table of Content

1. Introduction and Literature (p. 3-16)

- 1.1 Goal and structure of the lecture
- 1.2 Basic concepts in organic chemistry

2. Repetition of the Chemistry of Olefins and Carbonyls (p. 17-31)

- 2.1 Stereoselective synthesis of olefins
- 2.2 Hydroboration of olefins
- 2.3 Oxidation of olefins
- 2.4 Addition to carbonyls
- 2.5 Enolate generation and reactivity
- 2.6 Aldol reaction
- 2.7 Reactions of imines, enamines and conjugates systems
- 2.8 Limitations of classical methods involving olefins and carbonyls

3. Rearrangements (p. 32-51)

3.1 Sigmatropic rearrangements

3.1.1 [3,3] rearrangements

3.1.1.1 Cope rearrangements (Cope and Oxy Cope)

3.1.1.2 Claisen Rearrangements (Claisen, Ireland Claisen, Johnson Claisen, Eschenmoser Claisen, Carroll)

3.1.1.3 Other heterocyclic variations (Overman, Aza-Cope, Fischer Indole synthesis,...)

3.1.2 [3,2] rearrangements (Wittig, Evans-Mislow, Sommelet-Hauser,...)

3.2 Rearrangements via reactive intermediates

3.2.1 Cationic rearrangements

3.2.1.1 1,2-Shift on Carbon (Wagner-Meerwein, Pinacol, Tiffeneau-Demjanov, Prins-Pinacol, benzylic)

3.2.1.2 1,2-Shift on oxygen or nitrogen (Bayer-Villiger, Beckmann)

3.2.1.3 Dissociative rearrangements (Pummerer, Polonovski)

3.2.2 Rearrangement involving carbenes and nitrenes-like intermediates

3.2.2.1 Carbenes (Wolf, Arndt-Eistert homologation,)

3.2.2.2 Nitrenes (Hoffmann, Lossen, Curtius, Schmidt)

3.2.3 Other intermediates (Stevens, Favorskii, Neber)

4. Cyclization and Cycloaddition Reactions (p. 52-78)

4.1 Cyclization reactions using classical methods

4.1.1 Repetition of the Baldwin rules

4.1.2 (Macro)lactonization

4.2 Electrocyclic Reactions

4.2.1 Repetition of the Woodward-Hoffman rules

4.2.2 Electrocyclic ring-opening and closing

4.3 Ene Reactions

4.4 Cycloadditions

4.4.1 Diels-Alder Cycloadditions

4.4.1.1 General Mechanism

4.4.1.2 Normal electron demand Diels-Alder reactions

4.4.1.3 Inverse electron demand Diels-Alder reactions

4.4.1.4 Retro-Diels Alder reactions

4.4.1.5 Hetero-Diels Alder reactions (carbonyl, imines, SO₂, ...)

4.4.1.6 Stereoselectivity in the Diels-Alder reaction

4.4.2 [3+2] Cycloaddition reactions

4.4.2.1 1,3-Dipoles

4.4.2.2 Cycloaddition with azides and "Click" chemistry

4.4.3 Other cycloadditions

4.4.3.1 Cheletropic reactions (cyclopropanation, epoxidation, Corey-Winter reaction)

4.4.3.2 Others

5. Radical Methods and Photochemistry (p. 79-87)

5.1 Principles of radical reactions (Initiation, propagation, termination)

5.2 Radical-based cyclization and cascade reactions

5.3 Photochemistry in organic synthesis ([2+2] cycloadditions and other reactions)

6. Umpolung and Other Unusual Reactivity (p.88-89)

6.1 Principle of Umpolung and use of dithianes

6.2 Umpolung using nitro compounds

6.3 Catalytic Umpolung

7. Transition Metals in Organic Chemistry (p. 90-115)

7.1 Cross-coupling

7.1.1 Preparation of coupling partners

7.1.2 C-X/C-M couplings

7.1.3 Sonogashira coupling

7.1.4 Heck coupling

7.1.5 C-X coupling

7.2 Metathesis

7.3 Olefins and carbonyl functionalization

7.3.1 Nozaki Hiyama Kishi coupling

7.3.2 Allylic alkylation

7.4 C-H Functionalization

7.4.1 General Mechanism

7.4.2 Important Examples

7.5 Synthesis of carbocyclic and heterocyclic systems using metal catalysts

7.5.1 Annulation (cycloaddition) reactions

7.5.2 Cyclization reactions

1. Introduction

1.1 Goal and Structure of the Lecture

1.1.1 Goal of the Lecture

Scientific goals:

- Realize the limitation of classical carbonyl and olefin chemistry in organic synthesis
- Understand the synthetic potential of rearrangement and cycloaddition reactions in organic chemistry. The focus is on a qualitative understanding of the mechanisms, which allows you planning chemo-, regio- and stereoselectivity in synthesis.
- Understand the synthetic potential of radical and photochemical reactions.
- Introductions to the concept of reactivity reversal (Umpolung).
- First glance into to power of modern transition-metal-based methods in organic chemistry.

Main difference to Bachelor level: the reactions are now used in a specific and applied context in more complex, real-life problems, and not anymore limited only conceptual examples

Technical/pedagogic goals

- Deepen ability to draw reaction mechanisms and molecules in three dimensions
- Learning to recognize simple retrons and synthons in complex molecules.
- Application of simple principles in a new situation
- Increase independency from the lecture notes and the teacher

The goal of this course is to complement the basis of bachelor lectures to have a qualitative understanding of the mechanism of reactions and their synthetic potentials. The tools developed will then be used in the target synthesis course.

1.1.2 Structure of the lecture

The main part of the lecture is an ex-cathedra lecture on the blackboard. The blackboard lecture will consist mostly in illustrative and applied examples, as the general reaction model is presented in the script. There are 4 one hour exercises and for every week the POW (problem of the week).

- **Lecture notes:** The lecture notes will include all the important concepts and model of the lecture, but only few or no examples. Notes and the blackboard lectures are expected to complement each other and should always been studied in **parallel**.
- **Problem of the week:** The problem of the week will be in the style of an exam question relevant to the topic of the last lecture. They are expected to be turned in. If more than 80% are handed in and completed, a bonus of a two question pick will be given at the exam. The solutions will be available afterwards on moodle.
- **Exercise sessions:** Exercising is essential in organic chemistry. It is only through exercising that the concept can really be acquired. During the time of the exercise, teacher and assistant will be at the disposition for questions. The solutions will be available afterwards on moodle.
- **Exam:** The exam is oral and 15 min long. A transformation will be given without preparation and the candidate will be expected to discuss ad-hoc possible mechanisms and rationalize the selectivity observed. The question will be in the same format, but not identical to exercise questions.

1.1.3 Bibliography in Organic Chemistry

In the lecture notes, main bibliography references or reviews will be given for each chapter. The expected knowledge is based on the lecture notes, exercises, problem of the week and blackboard lecture. Nevertheless, it is always good to have a more comprehensive and deeper source of information of the topics to understand it better.

1.1.3.1 Basic knowledge, absolutely essential to follow this lecture:

- EPFL course: AIMF I-II, Fonction et réactions organiques I-III
- **Peter C. Vollhardt, Neil E Schore, *Organic Chemistry: Structure and Function***, Palgrave Macmillan. (édition 5, 6 prévue en 2010)
→ One of the best introductory book in organic chemistry.
- Jonathan Clayden, Nick Greeves, Stuart Warren, Peter Wothers, *Organic Chemistry*, 2001, Oxford University Press.

1.1.3.2 Advanced book in organic chemistry

General:

- **Francis A. Carey, Richard J. Sundberg, *Advanced Organic Chemistry Part A and B*** (two volumes), Fifth Edition, 2008, Springer.
+ Very complete book (2500 pages), often used in other countries, good description of reactivity, several chapters can be used to complete this lecture
- Repetitive content, weak in stereochemistry, **poor quality of the drawings**
- **Lazlo Kürti, Barbara Czako, *Strategic Applications of Named Reactions in Organic Synthesis***, 2005, Elsevier.
+ Excellent drawings quality. Very good overview of classical named reactions.
- No structure, dictionary of reactions
- **Erick M. Carreira, Lisbet Kvaerno, *Classics in Stereoselective Synthesis***, 2009, Wiley VCH.
Created from Master Course in Organic Chemistry at ETH Zurich
+ Specialized in the problem of stereoselectivity (good complement to Carey-Sundberg), good graphical quality.
- Michael B. Smith and Jerry March, *March's Advanced Organic Chemistry: Reactions, Mechanisms, and Structure*, sixth edition, 2007, John Wiley & Sons.
+ Lots of information, good for consultation on specific topic
- The information is too dense, cannot be used to learn

Reactions mechanism:

- **Reinhardt Brückner, *Organic Mechanisms: Reactions, Stereochemistry and Synthesis***, 2010, Springer.
+ One of the best books for mechanisms in organic chemistry at the qualitative-quantitative level.
- No applications in synthesis.
- Ian Fleming, *Molecular Orbitals and Organic Chemical Reactions*, 2009, Wiley.
+ Description of molecular orbitals at a level accessible for organic chemists. Cheap student version available.
- Explication of concepts only, not oriented towards synthesis.

Synthetic strategy: (books more relevant to lecture target synthesis)

- K. C. Nicolaou, E. J. Sorensen, *Classics in Total Synthesis*, 1995, Wiley VCH.

- + Historical collections of important synthesis in organic chemistry. Very well described and explained, including breakthroughs in methodology.
- The chronological and molecule-based structure makes it less adapted to support a lecture, unless the basic tools of organic chemistry are already known.
- K. C. Nicolaou, S. A. Snyder, *Classics in Total Synthesis II*, 2003, Wiley VCH. Follow up of the preceding book, less well done.
- Stuart Warren, Paul Wyatt, *Organic Synthesis: The Disconnection Approach*, 2nd edition, 2007, Wiley.
 - + Detailed discussion of retro-synthesis. Level is basic and easy to follow, even without experience in the field and correspond well to the level of Target Synthesis
 - Structure of the book is difficult to follow

Online Information :

- EPFL Moodle page for all course material in pdf-format
- **Evans Lecture** (look after Evans chem 206 in google). One of the best lecture in advanced organic chemistry.

1.2 Basic Concepts in Organic Chemistry

!!! The concepts presented in this summary are required for lecture and examination!!!

1.2.1. Important Principles in Organic Chemistry

In general, structures which can stabilize electrons are favored.

1.2.1.1 Electronegativity and "Octet" Rule

The electronegativity describes the ability of atoms to attract electrons. The nearest to octet (closed shell) the strongest the electronegativity. The electronegativity is weaker for larger atoms.

⇒ On chemical structures and during chemical reactions, the electrons go to the more electronegative element.

example: acidity		Me ₃ CH	Me ₂ NH	MeOH	HF	
	pK _a	53	> 36	> 16	> 3.2	⇒
	electronegativity	2.5	3.0	3.4	4.0	

The conjugate base is more stable for more electronegative atoms!

Indirect effect: inductive effect

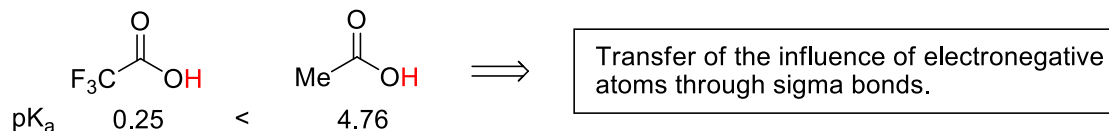

Effect of hybridization:

electron in orbitals with more s characters are more stabilized (more probability next to the nucleus)

example: acidity

	Me ₃ CH		H≡C-H
pK _a	53	50	24
Hybridization	Sp ³	SP ²	SP

1.2.1.2 Stabilization through Delocalization: delocalized charges (electrons) are more stable

1.2.1.2.1 Delocalization onto 1 atom: large atoms are more able to stabilize charges (= polarizable)

examples	1) acidity:		HF	HCl	HBr	HI
		pK _a	3.2	> -8	> -9	> -10
		electronegativity	4.0	3.2	3.0	2.7

⇒ Delocalization is more important than electronegativity in this case!

2) leaving group ability in substitution reaction

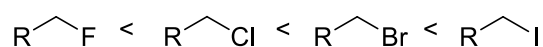

1.2.1.2.2 Delocalization on two atoms: the chemical bond

Important for organic chemistry:

- 1) σ bond is stronger than π bond for C=C bond, but not for C=N and C=O
- 2) Delocalization is better between atoms of the same size (orbital overlap)
- 3) For strong polar bonds: ionic part can become important and compensate the weaker covalent bonds: prediction is more difficult

examples:

	size effects								
σ bond:	C-H	C-C	C-N	C-O	C-F	C-F	C-Cl	C-I	
energy in Kcal	99	83	70	86	117	117	81	52	
π -bonds	C=C	C=N	C=O			C=O	C=S		
energy in Kcal	64	77	92			92	49		

⇒ Important practical consequence: in organic chemistry, losing C=C and making C=O is often favorable!

1.2.1.2.3 Delocalization on more than two atoms: resonance structures

Resonance structure = obtained by moving electron without changing position or connectivity of atoms

Resonance structures are essential to understand structure and reactivity in organic chemistry!

good resonance structure ↔ octet rule for 1. row elements, no charges, charges on electronegative atoms, more bonds, "better bonds", aromatic structures

stabilization through resonance (delocalization) is maximal if the **resonance structures are identical**

"reality" = weighted sums of the resonance structures

key examples:

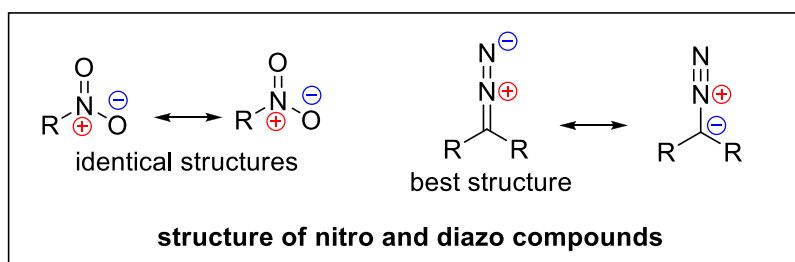
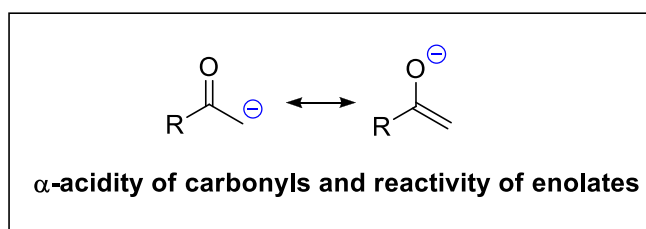
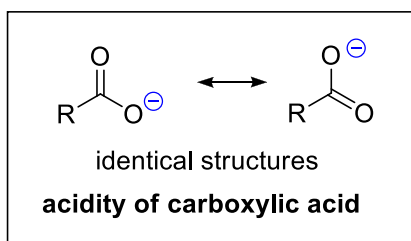
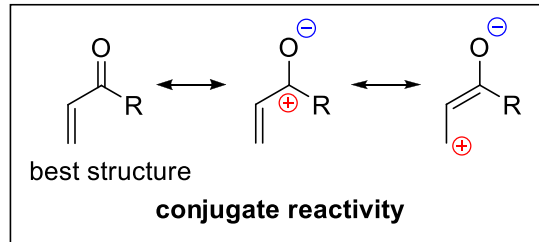
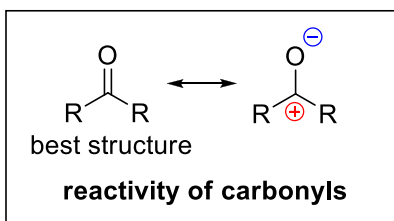

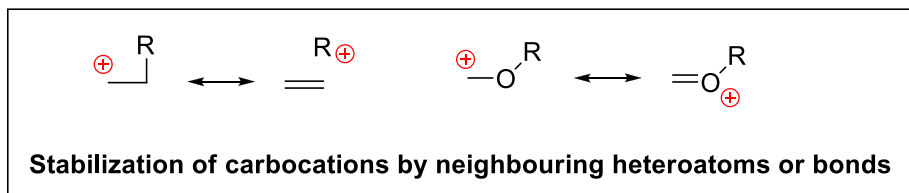

Limitation of resonance structure: description of aromaticity

aromatic stabilization: cyclic conjugate π -system with $4n+2$ electrons (Hückel's rule)

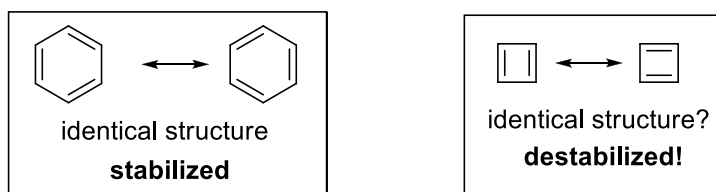

⇒ Higher level model is needed: orbital theory

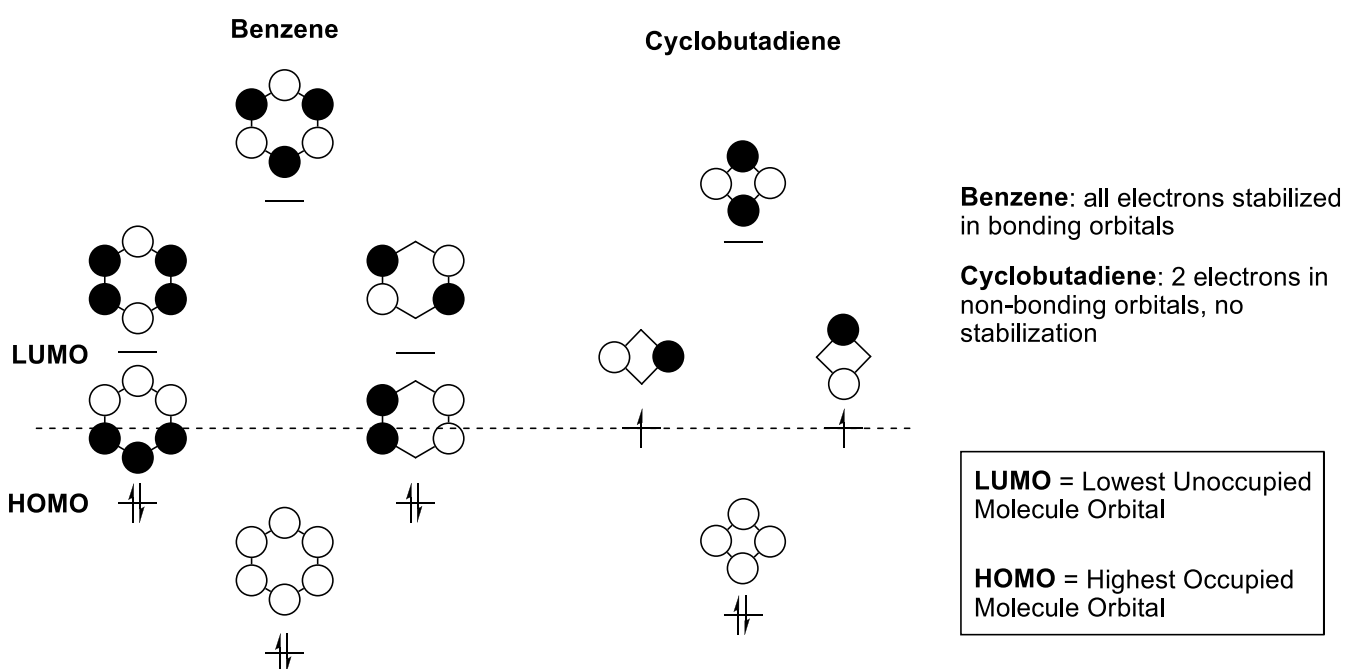

In organic chemistry, many observations can be explained by FMO (Frontier Molecular Orbital, LUMO and HOMO) considerations. This model is more powerful and precise than resonance/Lewis structure considerations, but need more time to apply.

Test for part 1

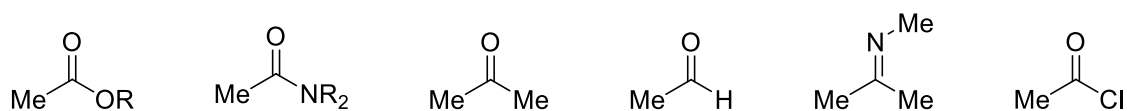

Classify these carbonyl compounds in order of increasing reactivity towards nucleophile addition.

1.2.2. Important Nucleophiles and Electrophiles in Bachelor Level Organic Chemistry

1.2.2.1 Nucleophiles

Heteroatoms	δ^- ROH	δ^- RNH ₂	δ^- RSH	δ^- PR ₃	δ^- R ₂ N-NH ₂	neutral
	alcohols	amines	thiols	phosphines	hydrazines	
	\ominus RO [⊖]	\ominus RNH [⊖]	\ominus RS [⊖]	\ominus X [⊖]		charged
	alkoxides	amides	thiolates	halogen anions		
Hydrides (H⁻) sources	δ^- NaBH ₄		δ^- LiAlH ₄			
	borohydrides		aluminium hydrides			
C Nucleophiles	δ^- RMgBr	δ^- RLi	δ^- OM R=C δ^-	M = Na, K, Li	δ^- OM R=C δ^- C(=O)X	
	Grignard	alkyl lithium	enolates		stabilized enolates	
	δ^- NR ₂	\ominus CN	ED C ₆ H ₄ δ^-	ED=C δ^-	ED = Electron-donating group	
	enamines	cyanide	electron-rich aromatic compounds and alkenes			

1.2.2.2 Electrophiles

H^+ M^+	RX	O R-C δ^+ -X	NR R=C δ^+ -X	$\text{R}-\text{N}^+\text{R}$ R=C δ^+ -X	EWG C ₆ H ₄ δ^+	EWG=C δ^+
proton metals	alkyl halogenide	carbonyls	imines	iminiums	electron-poor aromatic compounds and alkenes	
					EWG = Electron-withdrawing group	

1.2.2.3 Hard and Soft classification of Nucleophiles (Lewis Bases) and Electrophiles (Lewis Acids)

Hard \longleftrightarrow charged, localized electrons, highly electronegative/positive, reaction under charge control
typical hard electrophiles: H⁺, Mg²⁺, RCl, ROTf
typical hard nucleophiles: RMgBr, RLi, RO⁻, RNH⁻, F⁻, O atom of enolates

Soft \longleftrightarrow less charged, delocalized electrons, reaction under orbital (HOMO-LUMO) control
typical soft electrophiles: Pd²⁺, carbonyls, electron-poor double bonds and aromatic compounds
typical soft nucleophiles: C atom of enolates, stabilized enolates, electron-rich double bonds and aromatic compounds, I⁻, RNH₂, PR₃

Principle: **Hard-Hard and Soft-Soft interactions are favored!**

\implies Competition basicity-nucleophilicity: especially hard nucleophiles are usually also strong bases, because proton is hard (hard-hard interaction)

1.2.3. Important Classical Reactions in Bachelor Organic Chemistry

3.1 Substitution Reactions

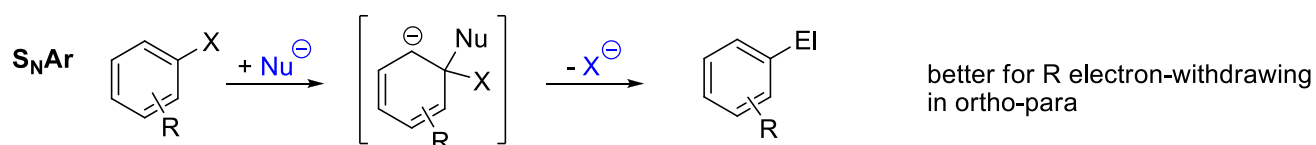
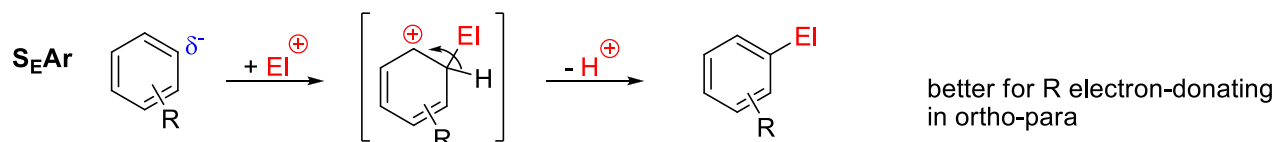
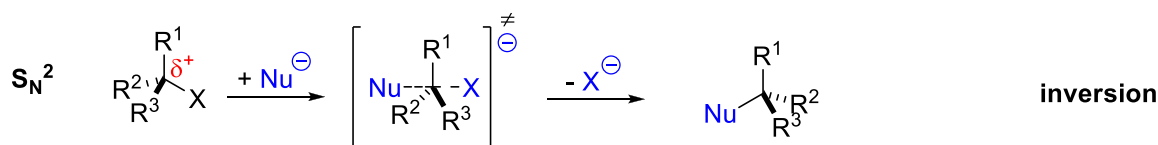
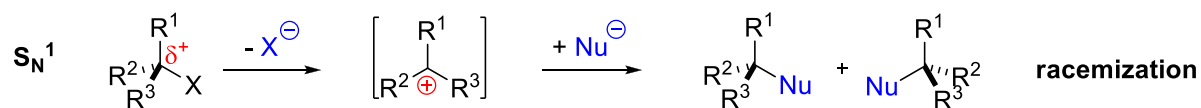

1.2.3.2 Elimination Reactions



1.2.3.3 Addition to double bonds

In principle: all mechanisms for elimination are possible in the reverse sense!

Special case: dibromination

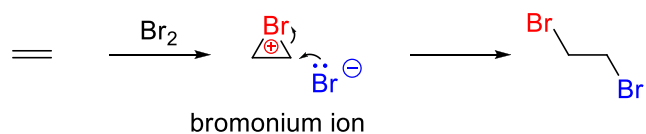

1.2.3.4 Chemistry of Carbonyls

1.2.3.4.1 Nucleophile Addition

Grignard

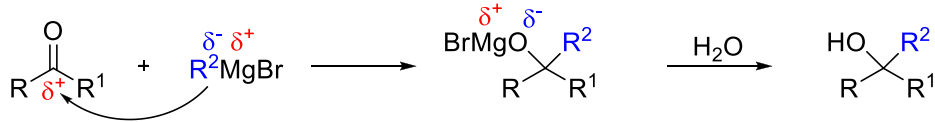

Hydride Reduction

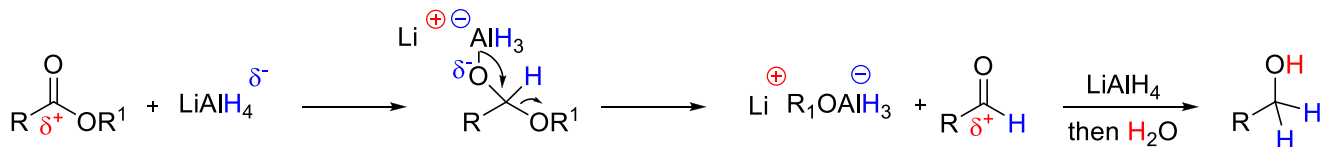
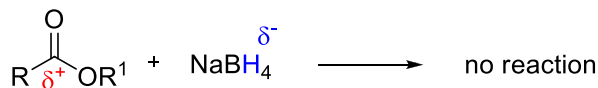
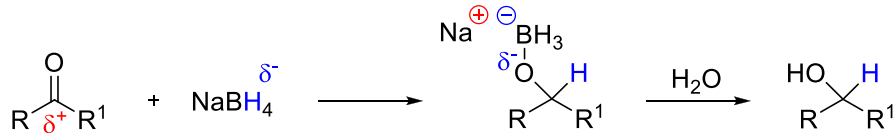

Alcohols: acetal formation under acidic catalysis

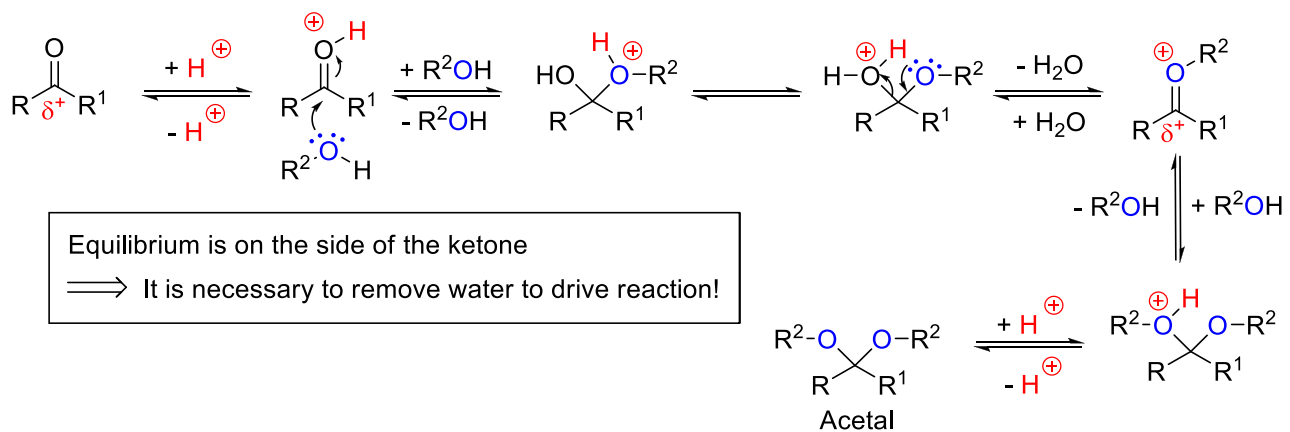

Equilibrium is on the side of the ketone
⇒ It is necessary to remove water to drive reaction!

Alcohols: ester formation under acidic catalysis

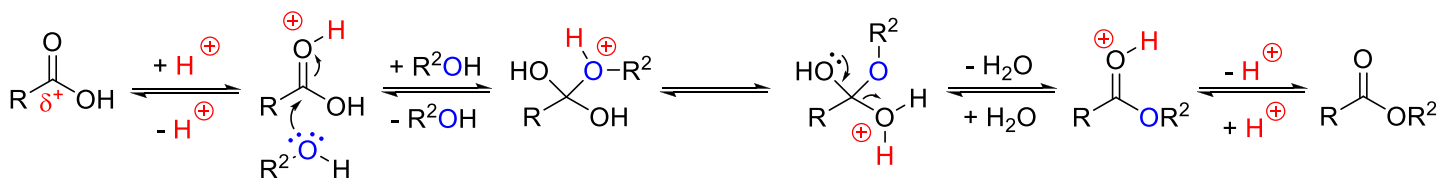

Equilibrium is nearly 1:1
⇒ Use excess alcohol to drive reaction

Ester Hydrolysis

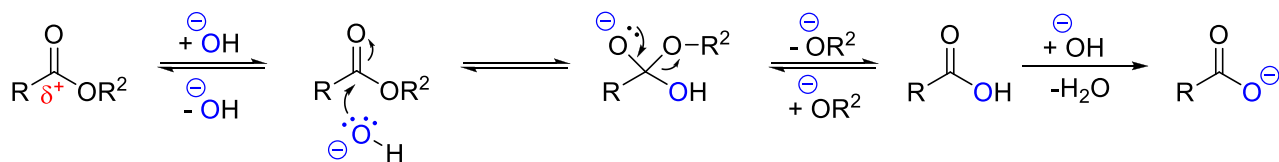

Stability of carboxylate \implies completely on the side of product!

Amine addition and imine formation

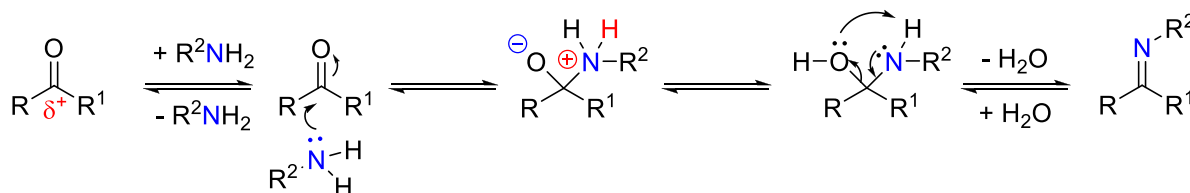

Water removal necessary for ketones, reaction easier with aldehyde

1.2.3.4.2 Enolate chemistry

Enolate alkylation

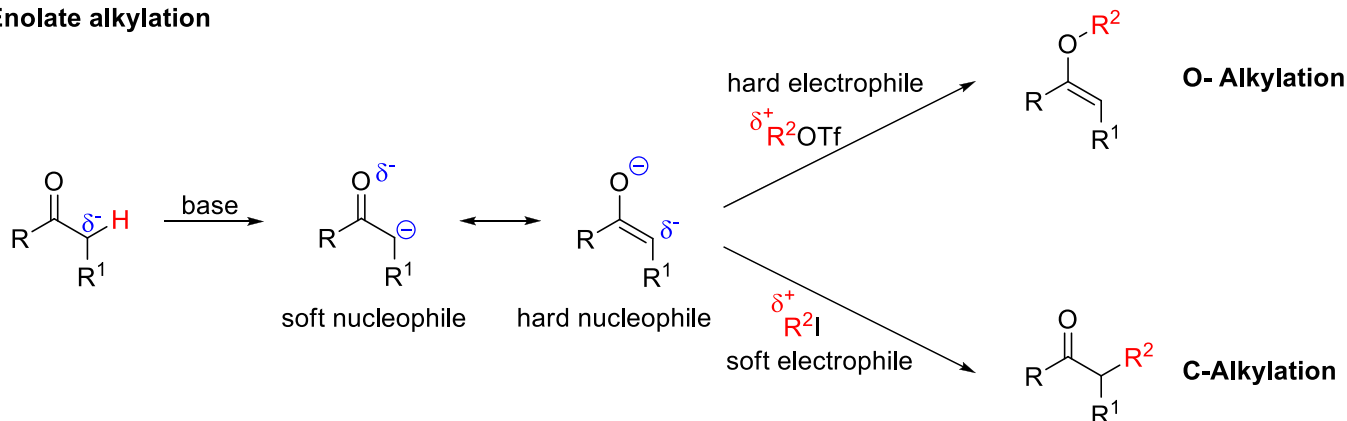

Aldol Reaction

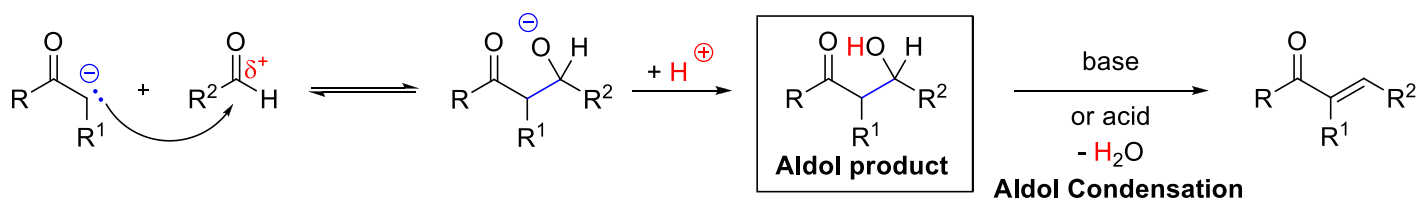

Claisen Condensation

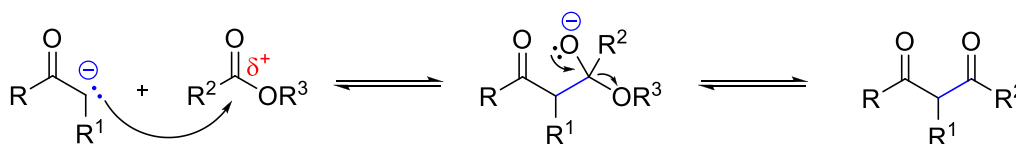

Other related reactions: Knoevenagel condensation, Perkin condensation, Dieckmann condensation.

Wittig Olefination

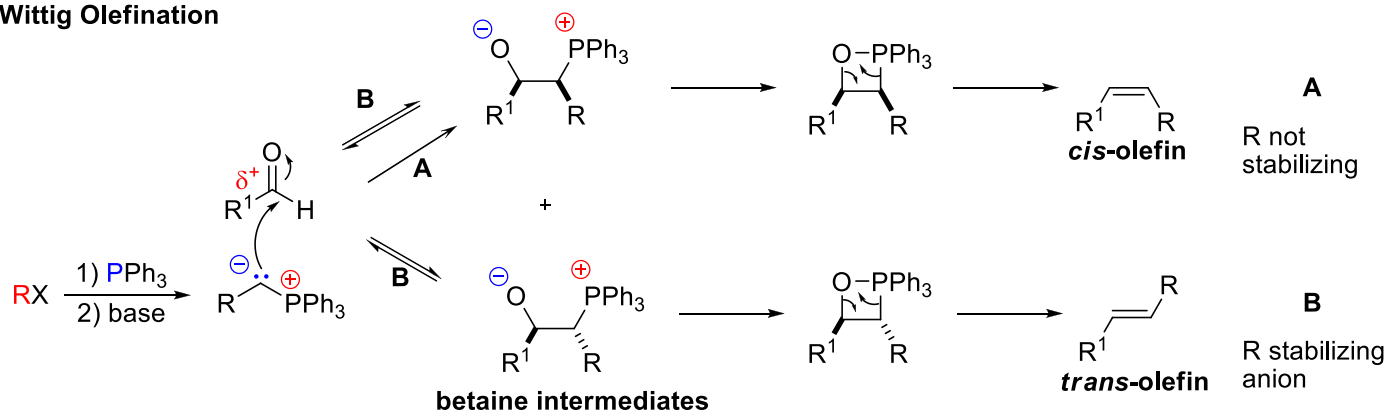

For non-stabilized ylides (**A**), formation of the *cis* betaine is favored and irreversible, leading to *cis* olefin. For stabilized ylides (**B**), an equilibrium leads to formation of the more stable *trans* betaine and finally to *trans* olefin.

1.2.3.5 Oxidation Reactions

Chrom(VI)

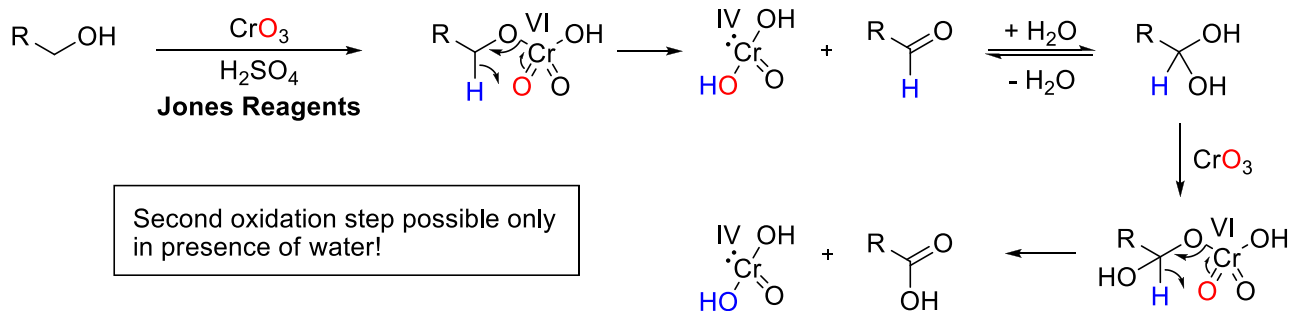

In practice also often used PDC (pyridinium dichromate), PCC (pyridinium chlorochromate)

Moffat-Swern

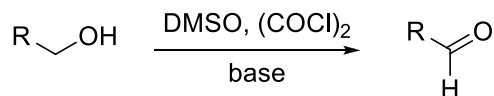

Mechanism

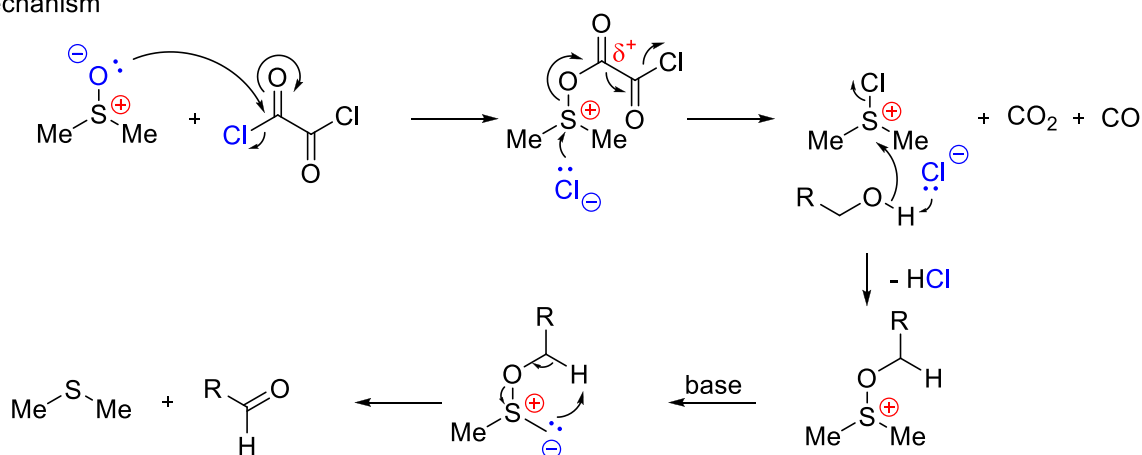

In practice, there are many more methods!

Dihydroxylation, Ozonolysis and Epoxidation

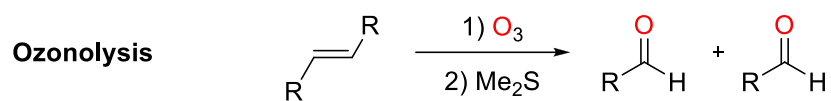

These reactions will be rediscussed in more details in the lecture

2. Repetition of the Chemistry of Olefins and Carbonyls

(For a more detailed description, see lecture "synthèse asymétrique")

2.1 Synthesis of Alkenes

2.1.1 Elimination

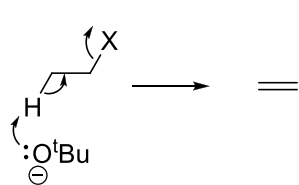

E₂, trans elimination

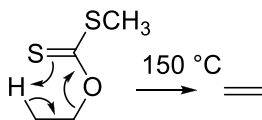

Chugaev syn elimination

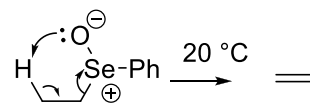

Selenoxide syn elimination

2.1.2 From Acetylenes

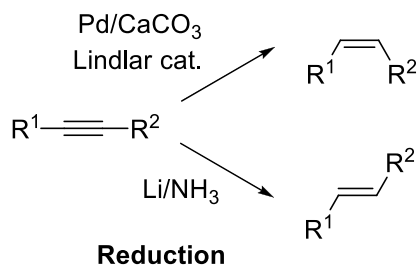

Reduction

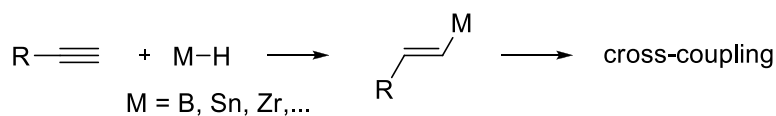

Hydrometallation

2.1.3 Olefin Metathesis (see inorganic chemistry lectures)

2.1.4 From carbonyls

2.1.4.1 Aldol Condensation

2.1.4.2 Wittig and Variations

Original Wittig

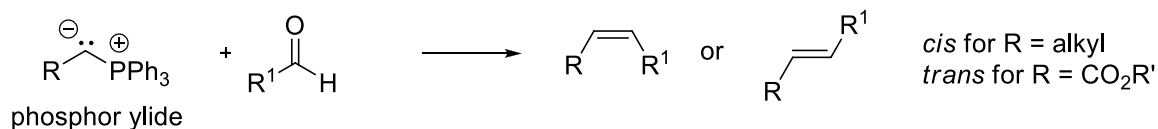

Mechanism

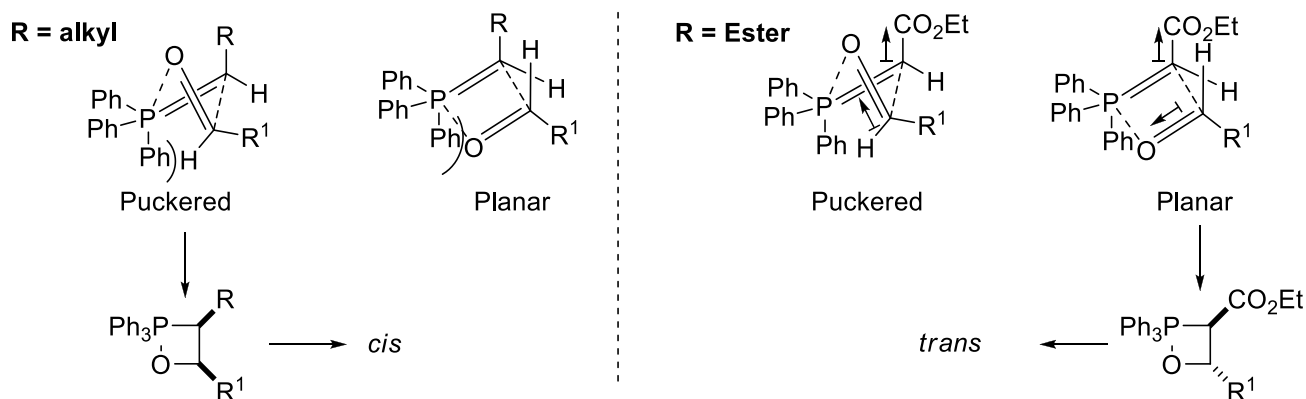

Two transition state are possible: puckerd and planar. For alkyl groups, the reaction is controlled by sterics and the puckerd TS is favored (less interactions with bulky Ph group). For esters, the reaction is controlled by electronics and the planar TS is favored (better Dipoles orientation).

Schlosser Variation

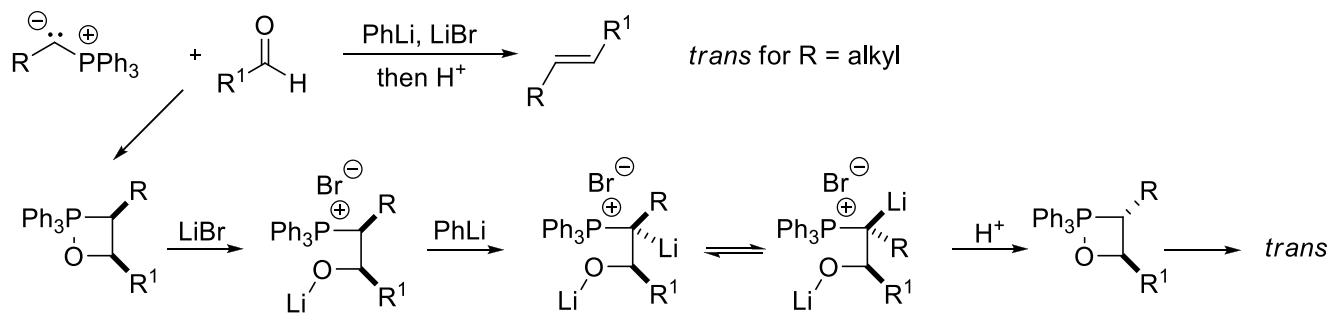

General problem with Wittig: Strong base is needed! It cannot be used for base-sensitive substrates.

Milder Variations:

Horner-Wadsworth-Emmons (HWE)

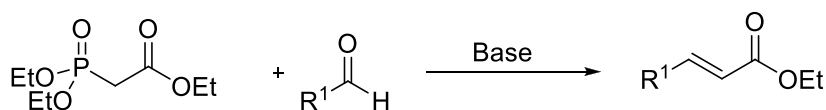

HWE is *trans* selective and weaker base can be used: very often used in total synthesis.

Cis-selective variations:

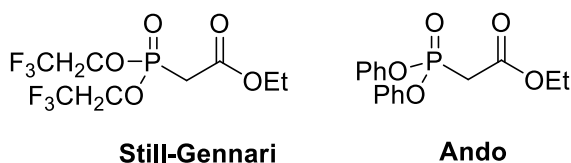

2.1.4.3 Julia and Variations

Julia-Lythgoe

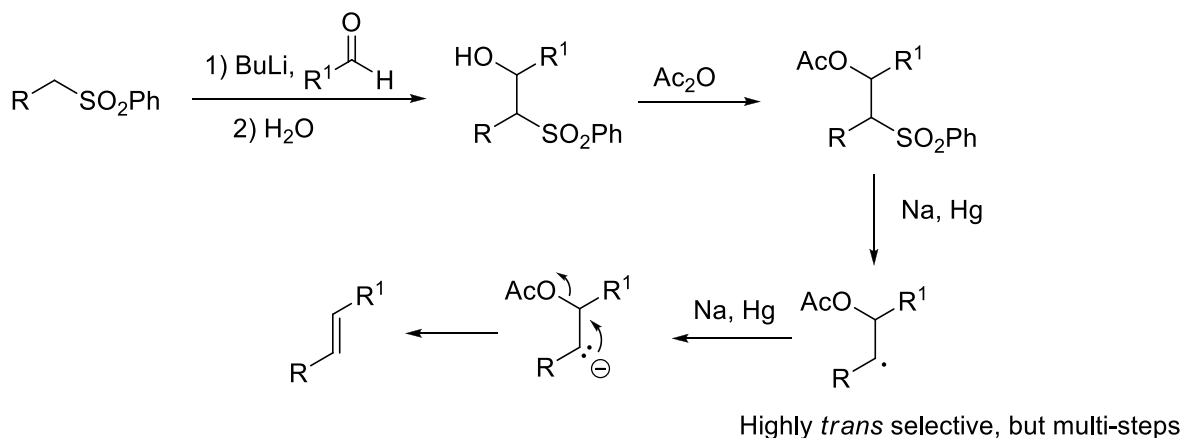

Julia-Kocienski

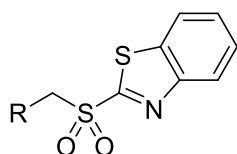

1 step only

Highly *trans* selective, milder than many Wittig methods

2.1.4.4 Peterson Olefination

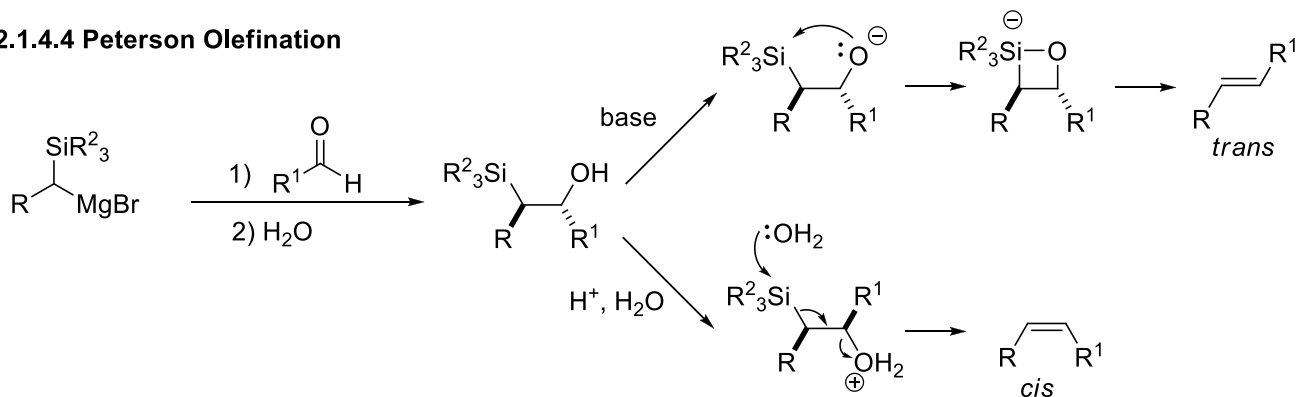

If high selectivity can be achieved in the first step, the Peterson protocol allows obtaining *trans* or *cis* olefins depending on the reaction conditions.

2.2 Hydroboration of Alkenes

2.2.1 Important Boron Reagents and General Mechanism

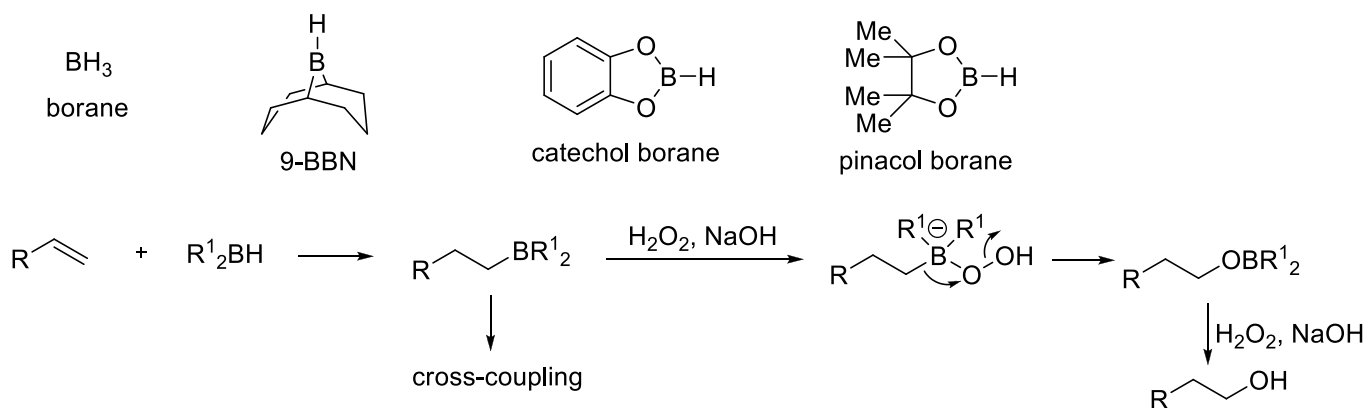

Regioselectivity: H goes to more stabilized carbocation, because the mechanism is asynchronous:

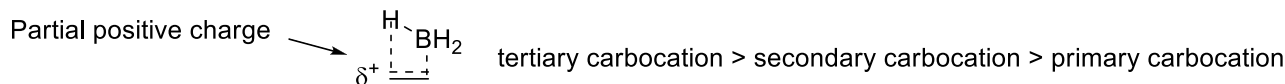

2.2.2 Control of Diastereoselectivity

Hydroboration with BH_3 : Minimize strongest Allylic strain, BH_3 comes opposite from R_L

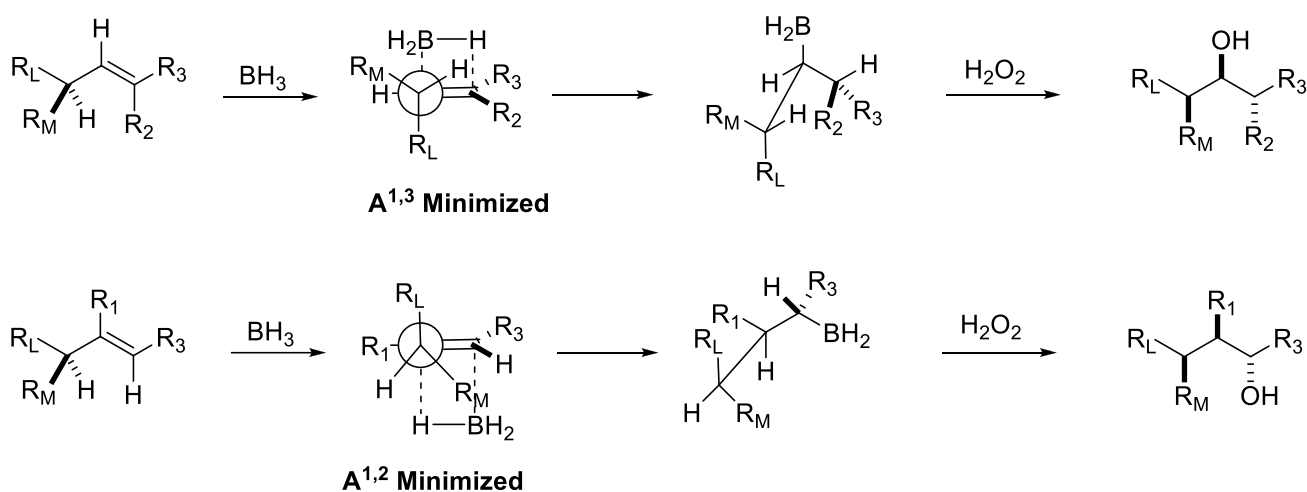

Hydroboration with bulky boron reagents: **Minimize reagent-substrate interactions**

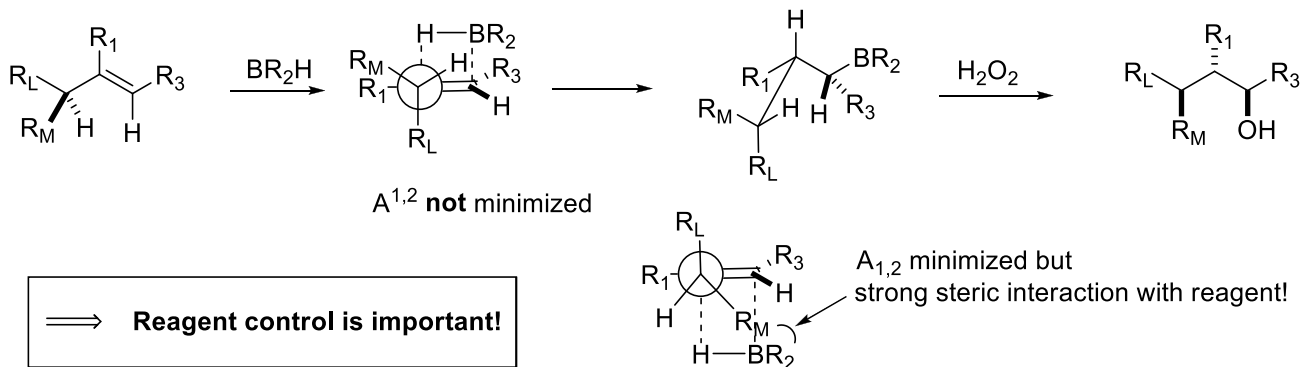

2.3 Alkene Oxidation

2.3.1 Epoxidation

2.3.1.1 Directed Epoxidation with *m*-CPBA

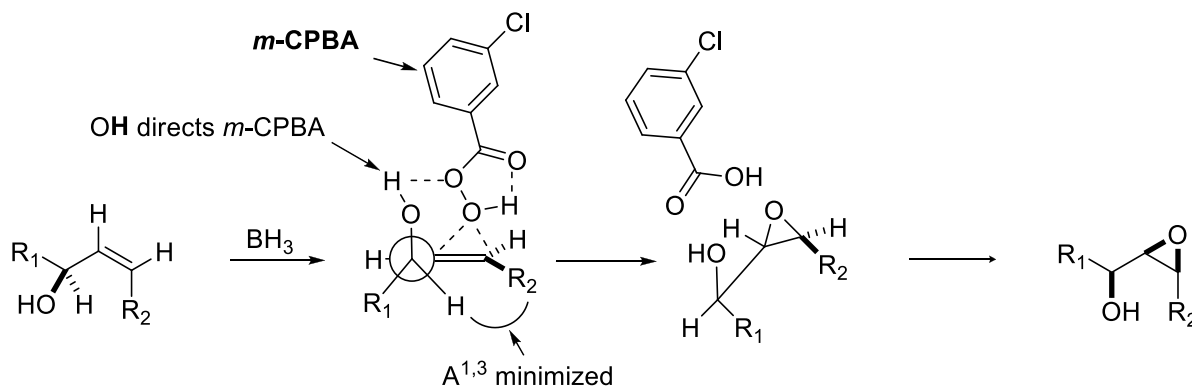

Directed reactions often allows for good selectivity in organic chemistry!

2.3.1.2 Directed Epoxidation with metal catalysts

General Mechanism

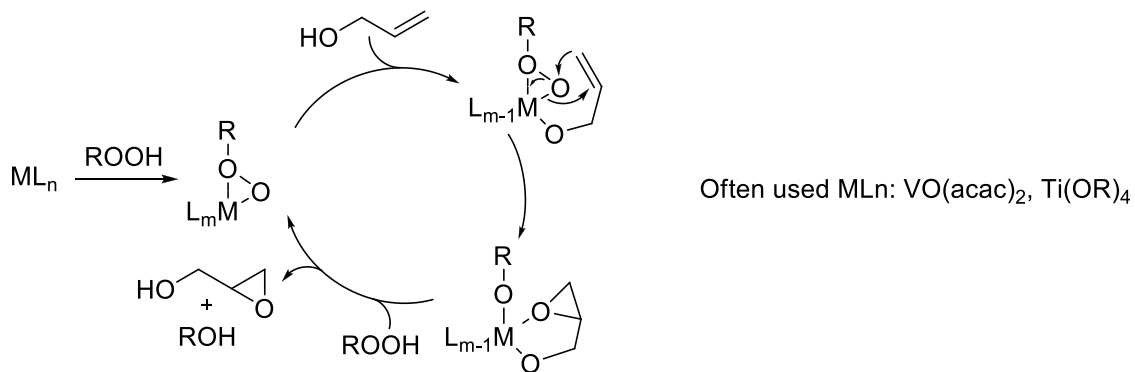

Catalytic Asymmetric Version: Sharpless Epoxidation

conditions: 5 mol% $\text{Ti}(\text{O}^i\text{Pr})_4$, 5 mol% DET, $t\text{BuOOH}$, molecular sieves, CH_2Cl_2 , -20°C

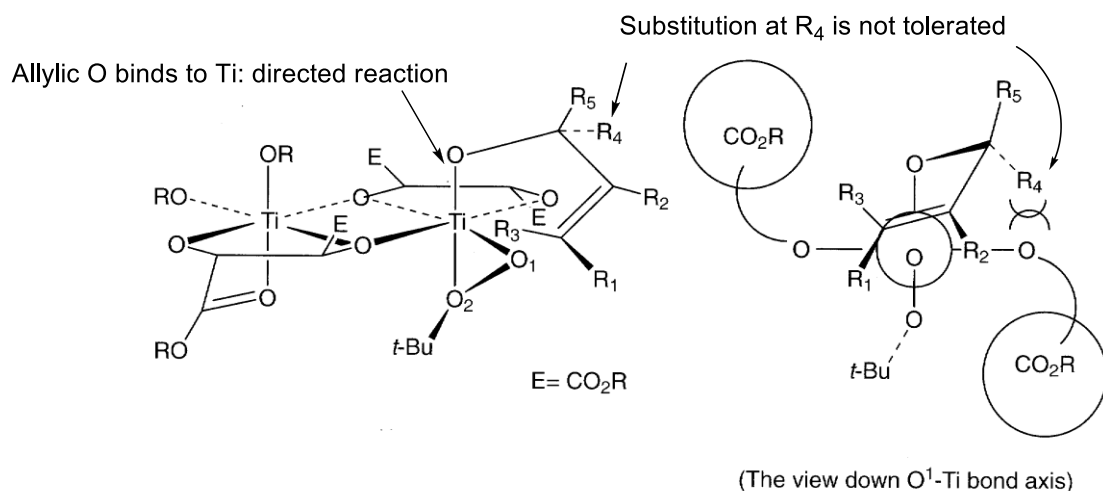
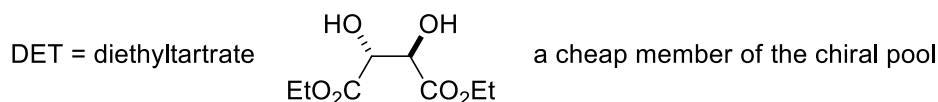

Important:

- $t\text{BuOOH}$ does not react until bound to Ti \Rightarrow Catalysis is possible
- Face of attack of the peroxide is determined by the chiral diester ligand, not the conformation of the substrate \Rightarrow very good reagent control

The Sharpless epoxidation is very often used for the synthesis of complex organic molecules!

2.3.1.3 Epoxide Opening and the Fürst-Plattner Rule

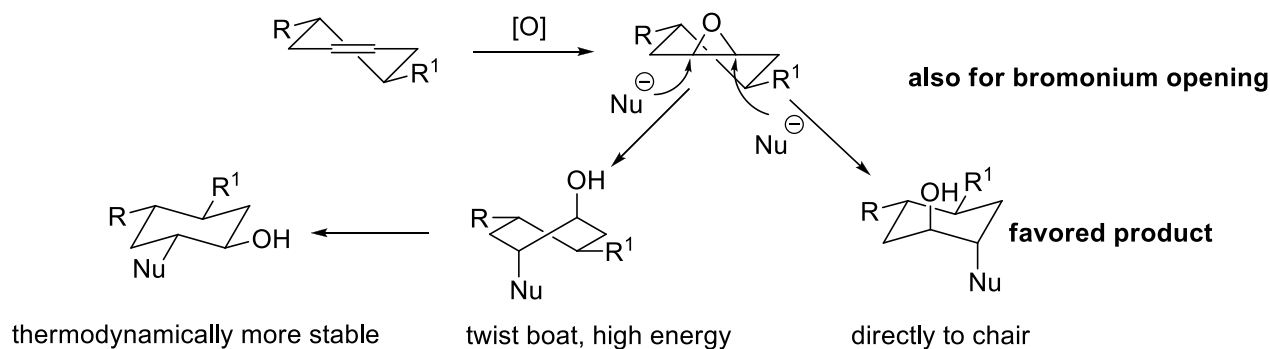

\Rightarrow The thermodynamically more stable product is not observed, because an unfavorable twist-boat intermediate has to be formed.

2.3.2 Dihydroxylation

General Mechanism

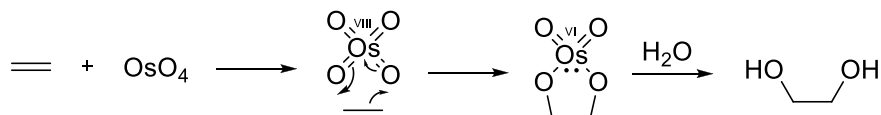

Problem with first method: Stoichiometric use of very toxic and expensive OsO₄

Sharpless Catalytic Asymmetric Dihydroxylation: Ad-mix

5 mol% K₂OsO₄(OH)₄ (catalyst)
K₃Fe(CN)₆ (stoichiometric oxidant)
cinchona-derived amines (chiral ligand)
Inorganic Base

sold as Ad-mix

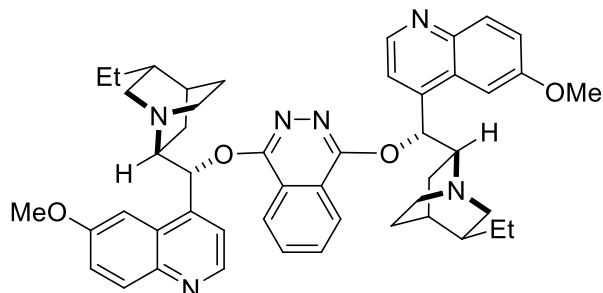

(DHQD)₂-PHAL

example of chiral ligand

The Sharpless dihydroxylation is the most used method for the asymmetric synthesis of diols.

This reaction will be discussed in details in the course catalytic asymmetric reactions in organic synthesis.

2.4. Addition to Carbonyl

2.4.1 General Concepts and Models

Comparison with Olefins

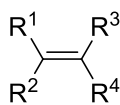

Olefins

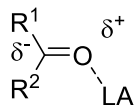

Carbonyls

- Sterics is different: only lone pairs on O
- C=O bond is polarized: no issue of regiochemistry
- Further activation of carbonyls with Lewis Acids is easy and allow to modulate the reactivity

Felkin-Ahn Model

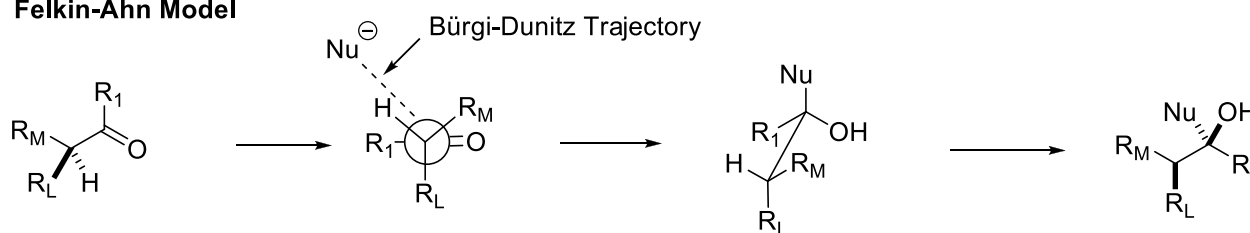

- R_L is ⊥ to C=O
- Nu comes along the Bürgi-Dunitz trajectory (109 °C to C=O)
- Minimize Nu-Substrate interaction ⇒ Smallest Substituent on Bürgi-Dunitz trajectory (Here H)

Polar Felkin-Ahn Rule

Electron-deficient groups behave as R_L

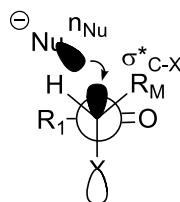

Favorable Interaction n_{Nu} to σ*_{C-X}

X = OR, F, Cl, Br, I, ...

2.4.2. Addition to Carbonyls not Following the Felkin Ahn Model

2.4.2.1. Chelate Control

1,2 Chelate control

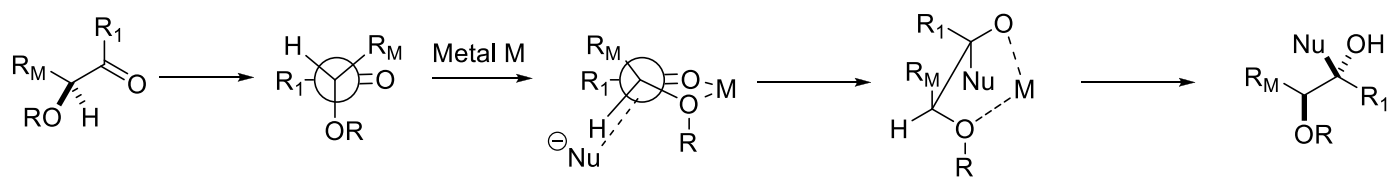

- Metal forces two donors in plane through chelation
- Nu comes towards smallest substituent (H)

1,3 Chelate control

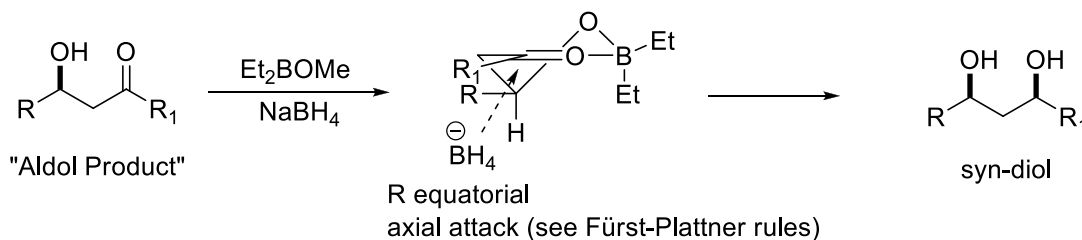

Factors favoring chelation

- R group sterically not hindered:

good: R = Me, Bn, MeOCH₂ (MOM), BnOCH₂ (BOM)

bad: R = ^tBu, SiMe₃, SiMe₂^tBu (TBDMS or TBS), SiⁱPr₃ (TIPS)

- non-coordinating solvents:

Toluene, CH₂Cl₂ >> Et₂O > THF >> DMF, EtOH, H₂O

- Strong Lewis Acid, with more than one coordination site available

Bad: Na⁺, K⁺ (too weak Lewis Acid), BF₃ (only 1 coordination site), LiX

Good: MgX₂, ZnX₂, LiX, TiCl₄, SnCl₄, SnCl₂, LnX₃, AlCl₃,...

Importance of anion X: If X is not too tightly bond to the metal, it can dissociate generating a new free coordination site. F⁻, R⁻ generally don't dissociate, Cl⁻ and OAc⁻ can dissociate and Br⁻, I⁻, OTf⁻ often dissociate easily. For example BF₃ is not a chelating agent, but BBU₂OTf is a chelating agent.

2.4.2.2. Directed Reduction

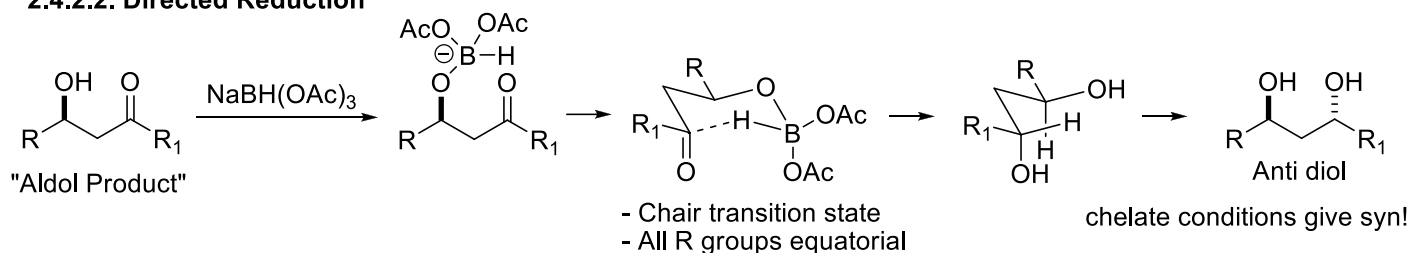

Sodium trisacetoxo borohydride is a very weak reducing reagent ⇒ Only intramolecular reduction is possible

Use of chelate conditions or directed reductions allow to access both syn and anti diols from aldol synthons, and are also essential methods for the selective synthesis of polyols polyketide natural products.

2.4.2.3 Reagents Binding to Carbonyl during Addition

Borane Reduction

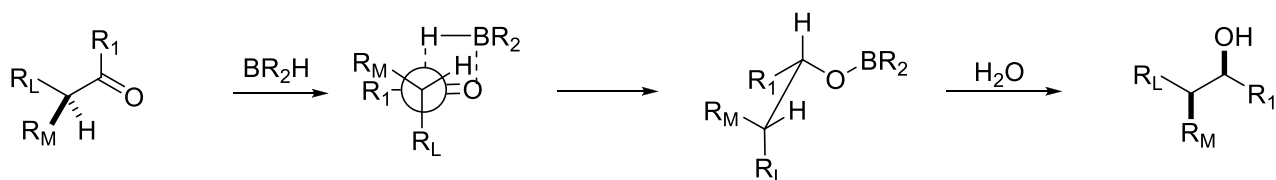

- R_L is \perp to $C=O$
- BR_2 bind to O during reduction
- Minimize BR_2 -Substrate interaction \Rightarrow Smallest Substituent towards BR_2 (H)

Other important examples where Felkin-Ahn models does not apply:

Allylation, Aldol Reactions via Chair Transition States

2.4.3 Allylation of Carbonyls

Allylation

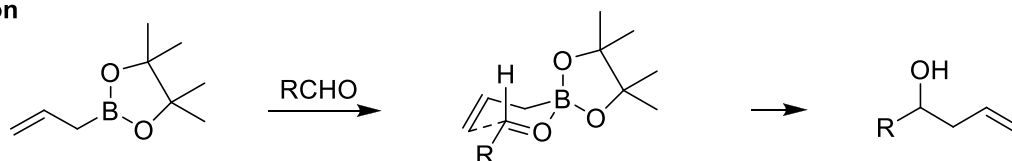

Crotylation

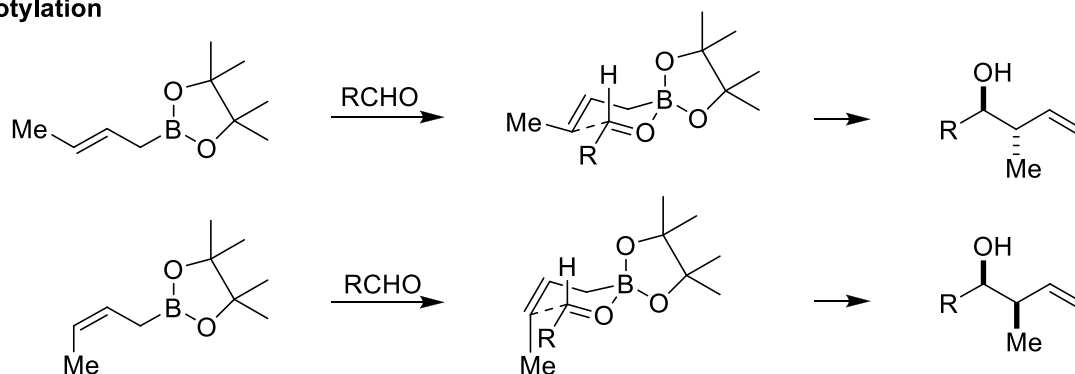

- 6-membered, chair transition state
- Substituent in equatorial position
- Transfer from double bond geometry to stereochemistry (*E* to anti, *Z* to cis)

Chiral Reagents For Allylation Reactions

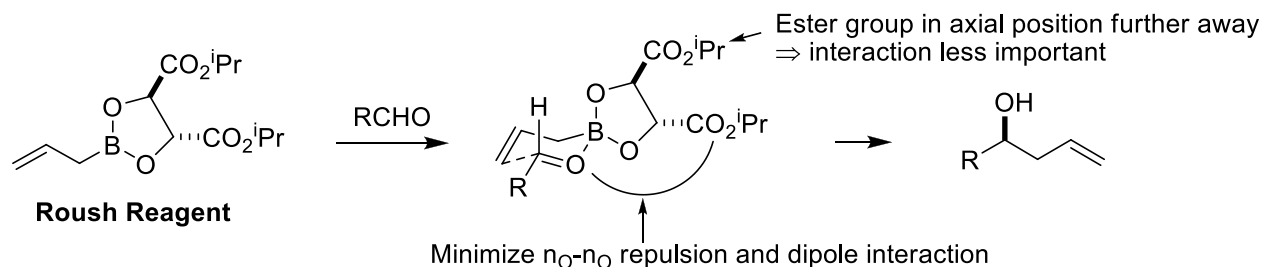

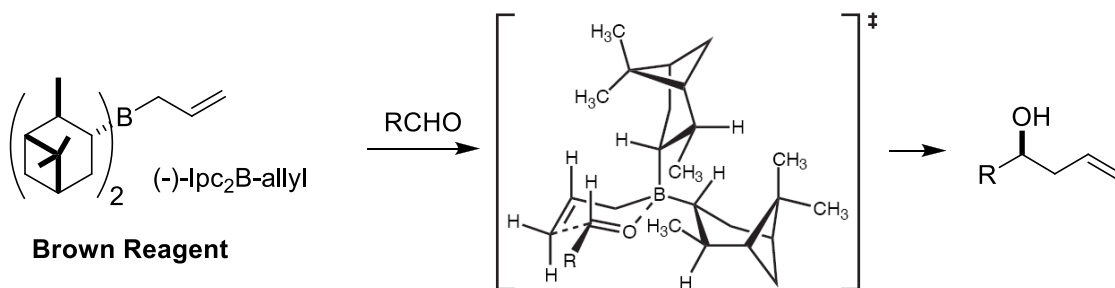

Brown Ipc reagent is very reliable and often used in total synthesis.

2.5. Enolate Generation and Reactivity

2.5.1 Selective Generation of Enolates

Kinetic vs thermodynamic control

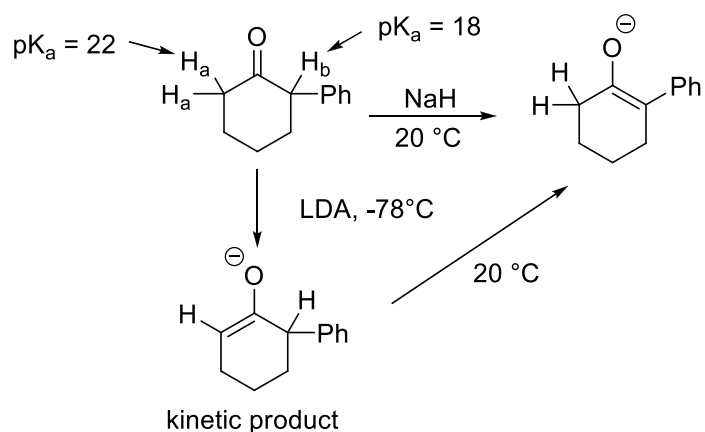

H_a is less sterically hindered, faster to deprotonate and leads to the kinetic product with bulky base at low temperature.

Deprotonation of H_b leads to the more stable conjugated double bond, the thermodynamic product, at higher temperature.

Important bases for kinetic deprotonation:

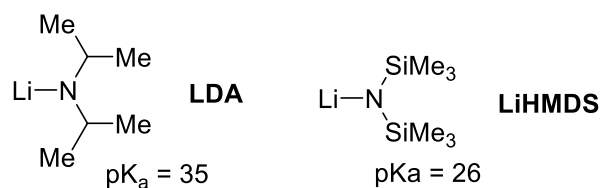

Deprotonation with LDA: cis vs trans selectivity

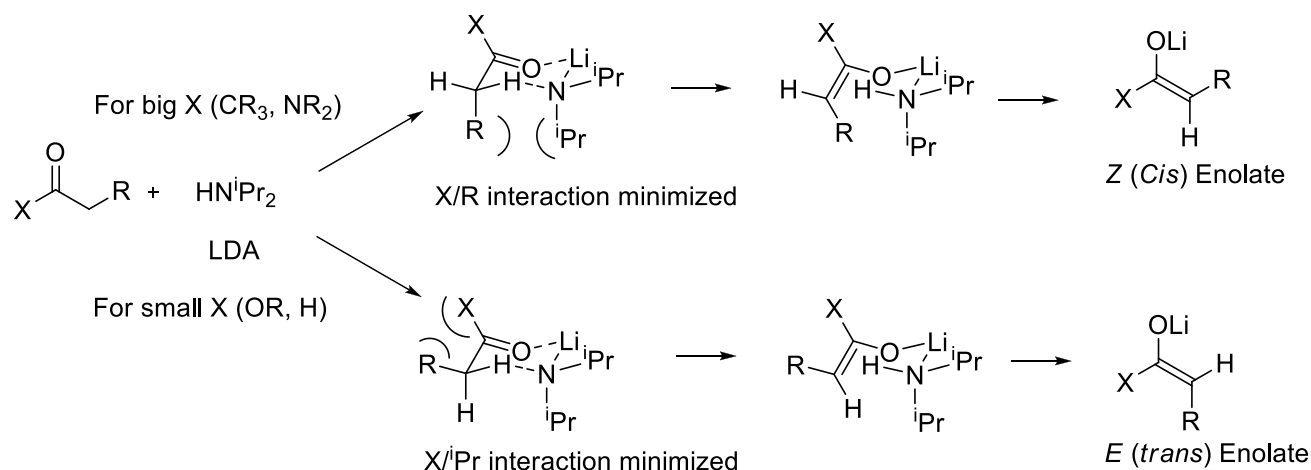

exception for esters: Adding HMPA leads to Z (Cis) Enolate

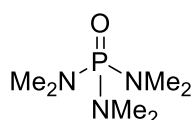

HMPA: good ligand for lithium \Rightarrow Cyclic transition state is partially disrupted

Deprotonation of Imides with Bu₂BOTf and NEt₃ (soft enolization)

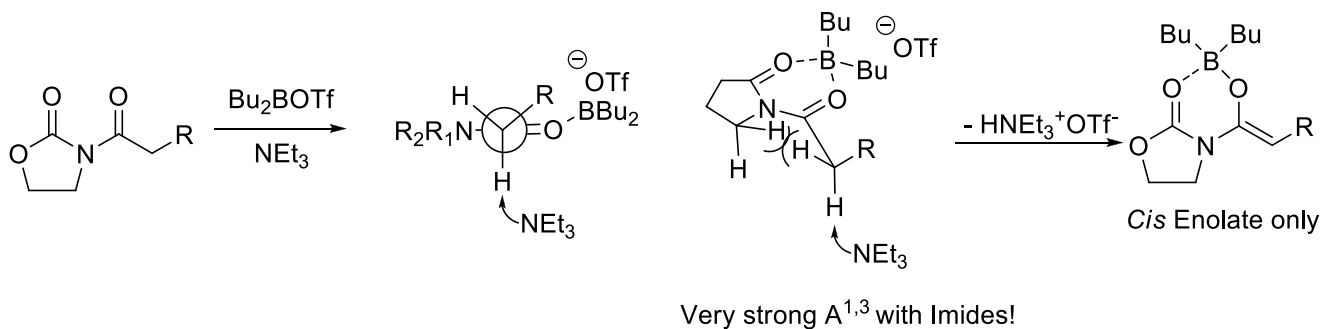

Deprotonation of Ketones

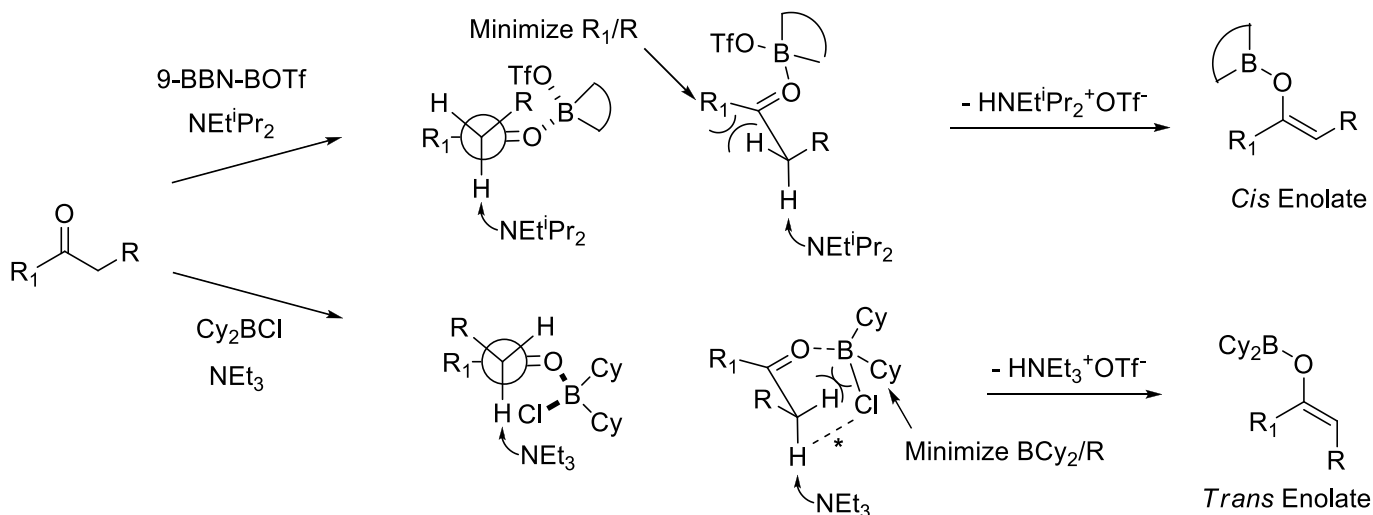

*The complete switch of selectivity is not well understood, some authors proposed an extra Cl-hydrogen interaction

2.5.2 Chiral Auxiliary and Enolate Alkylation

2.5.2.1 General Concept

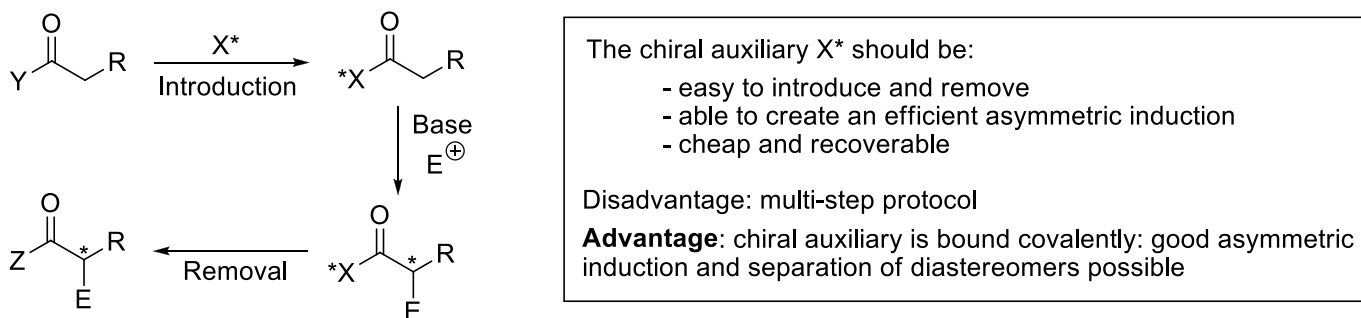

2.5.2.2 Evans Oxazolidinone Auxiliary

Synthesis: easy from cheap natural amino acid

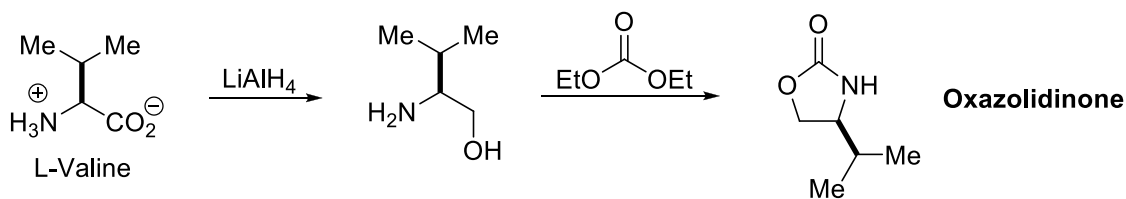

Auxiliary Introduction

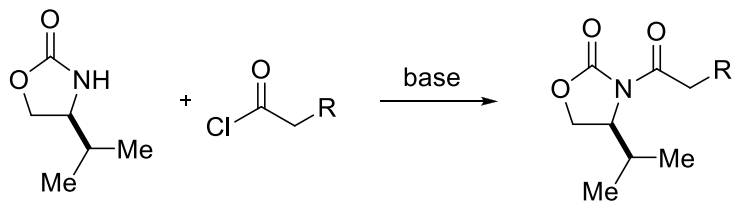

Enolate Alkylation

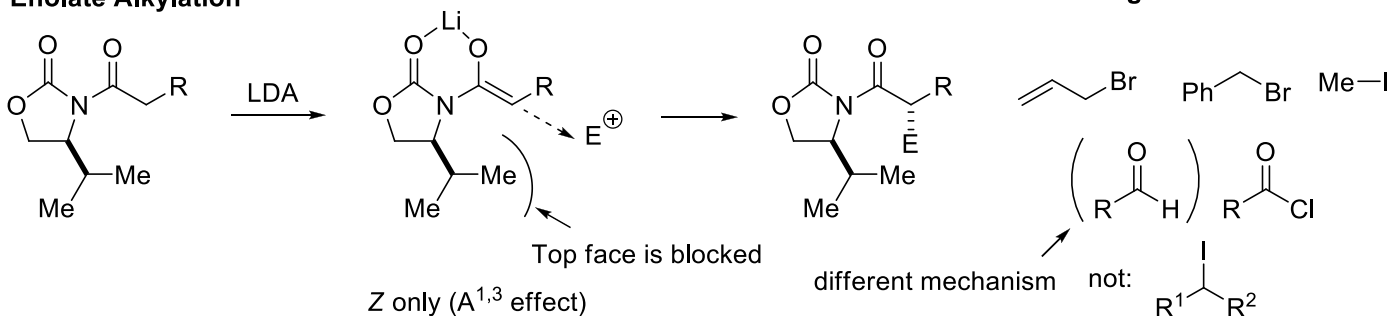

Auxiliary Removal

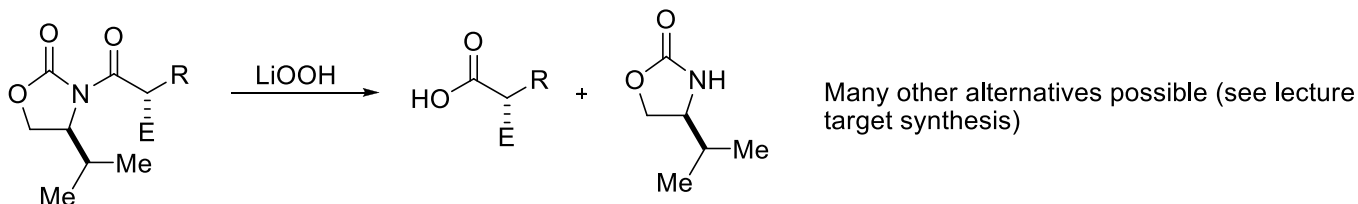

2.5.2.3 Other Auxiliaries

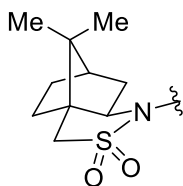

Oppolzer Sultam
From Camphor

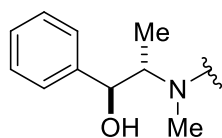

Myers Pseudoephedrin auxiliary

Myers auxiliary is often used for alkylation reaction in synthesis, as the enolate formed are more reactive than the ones from Evans' auxiliary

2.6. Aldol Reaction

2.6.1 Zimmermann-Traxler Transition State

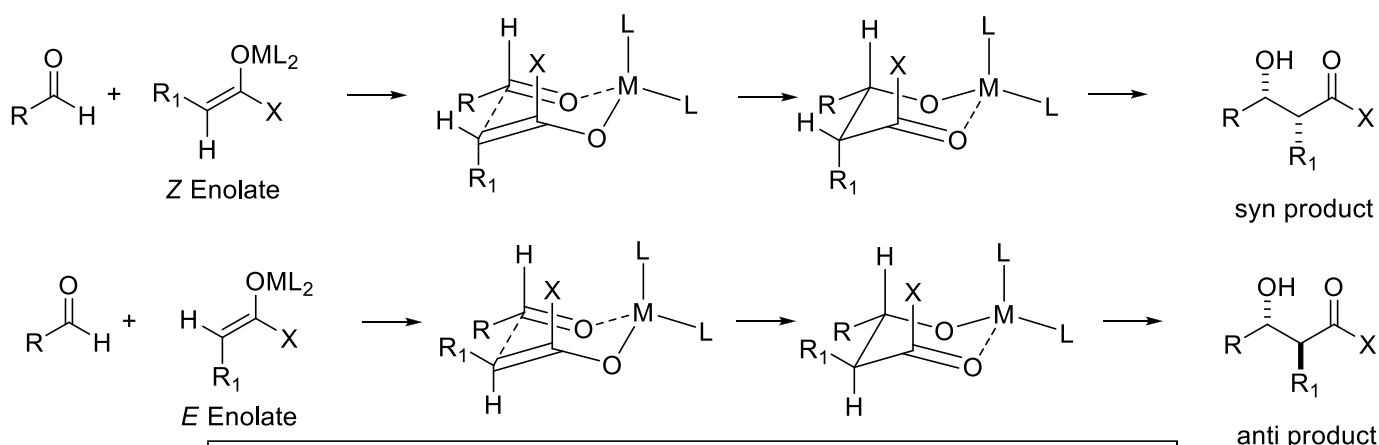

- Chair transition state (Zimmerman-Traxler)
- R group of aldehyde equatorial
- Geometry of double bond transferred to stereocenter: *cis* to *syn*, *trans* to *anti*

2.6.2 Aldol Reactions using Evans' Auxiliary

Evans Syn Aldol:

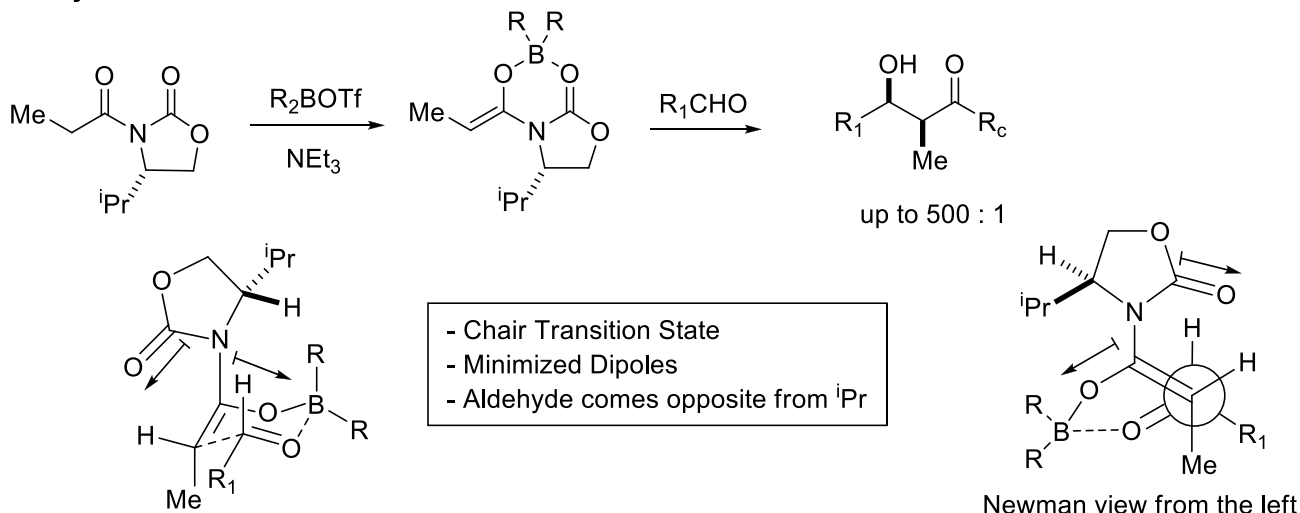

Important: In order to activate the aldehyde for addition, B has to bind to the aldehyde. As B has only two free binding sites, the oxazolidinone carbonyl is now free and rotates to minimize dipole interactions.

Crimmins Syn Aldol

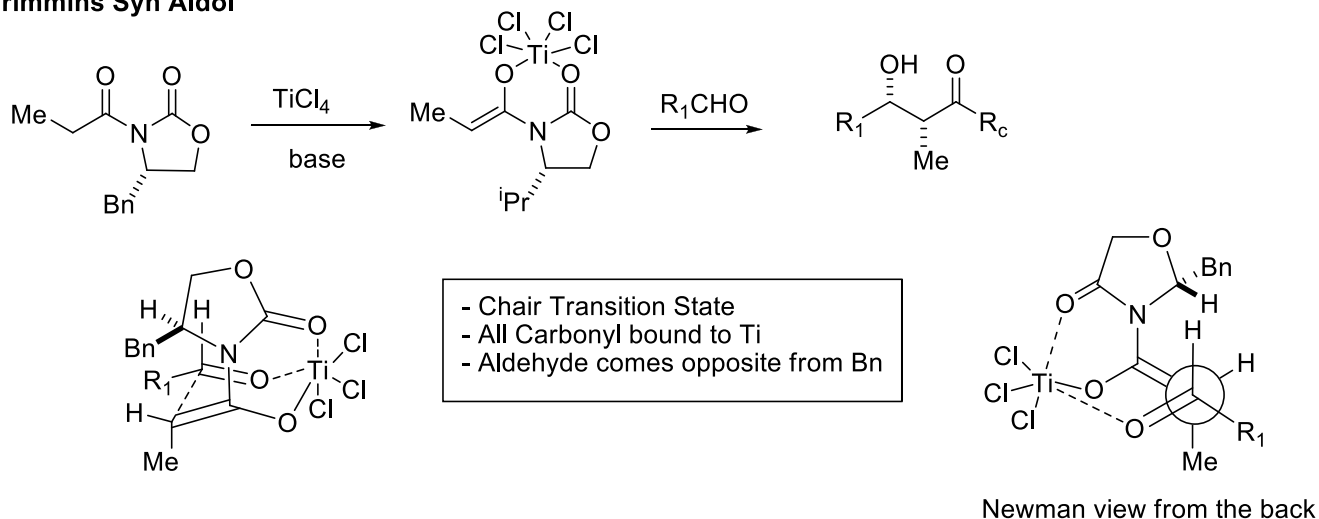

Anti aldol with external Lewis Acid

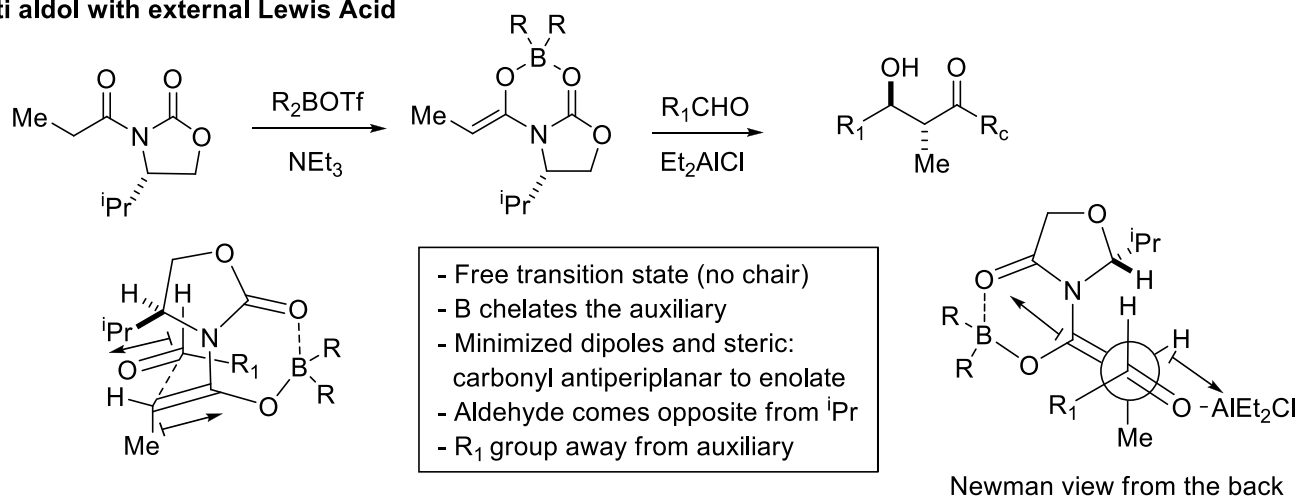

2.6.3 Ketone (Paterson) Aldol

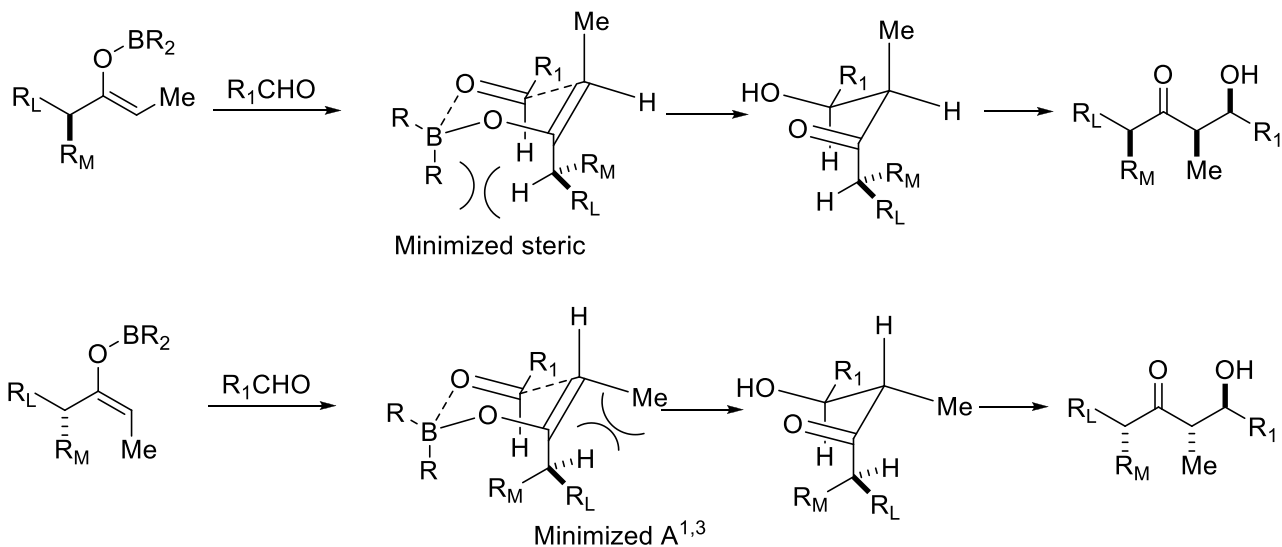

- Chair transition state
- R₁ group of aldehyde equatorial
- position of chiral group: minimize steric interaction with BR₂ for *cis* enolate, aldehyde comes towards R_M, not R_L, minimize A^{1,3} with Me of enolate for *trans* enolate, R_M and not R_L towards BR₂, aldehyde comes towards H

2.7. Reaction of Imines and Conjugated Systems (Mannich, Michael Reactions)

2.7.1 Chemistry of Imines

Comparison of Reactivity as Electrophile

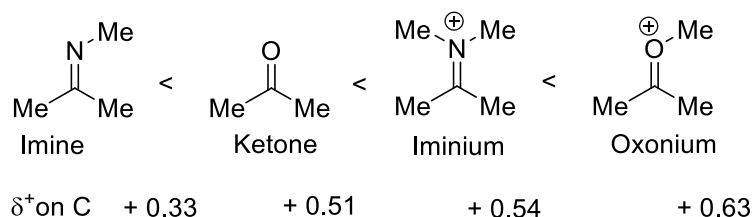

Imine are less reactive as electrophile than carbonyl compounds, but they are easy to activate as iminium

Reductive Amination

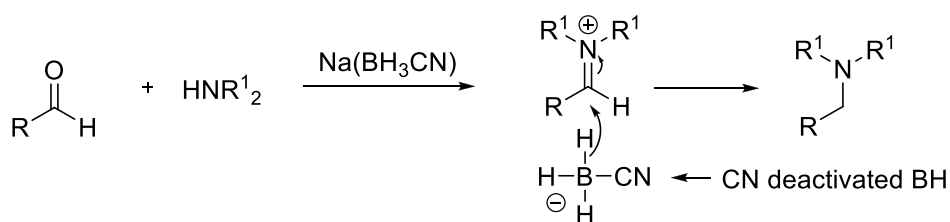

Because of the electron-withdrawing CN group, Na(BH₃CN) is not able to reduce carbonyls, but it is strong enough to reduce the more reactive iminium.

Mannich Reaction = Imine equivalent of aldol reaction

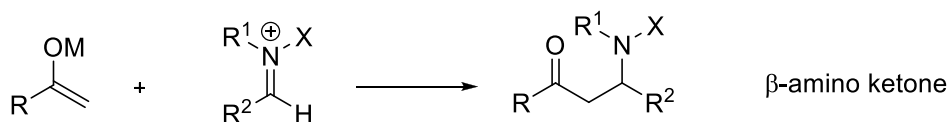

2.7.2 Chemistry of Enamine and Metalloenamine

Comparison of Nucleophilicity

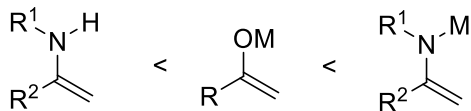

Enamine are easily formed from iminium, but less nucleophilic than enolate. Metalloenamine are very reactive.

Enders SAMP Chiral Auxiliary for Ketone

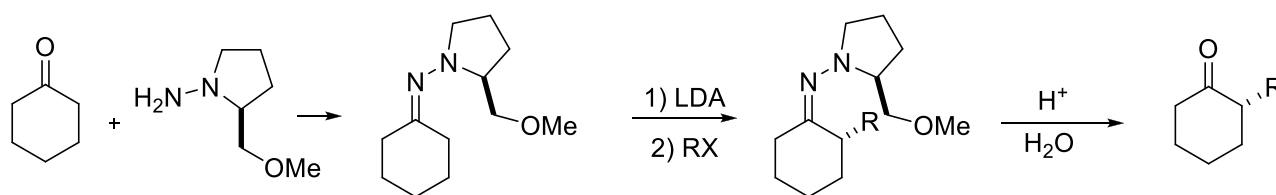

SAMP Hydrazone

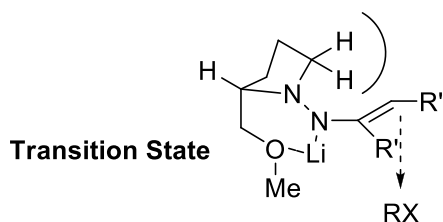

Transition State

- A highly reactive Li enamine is formed
- The Li metal is bound opposite to the enamine double bond to minimize steric interactions with the electrophile
- The electrophile comes opposite to the pyrrolidine ring

Proline Catalyzed Aldol: via enamine intermediates

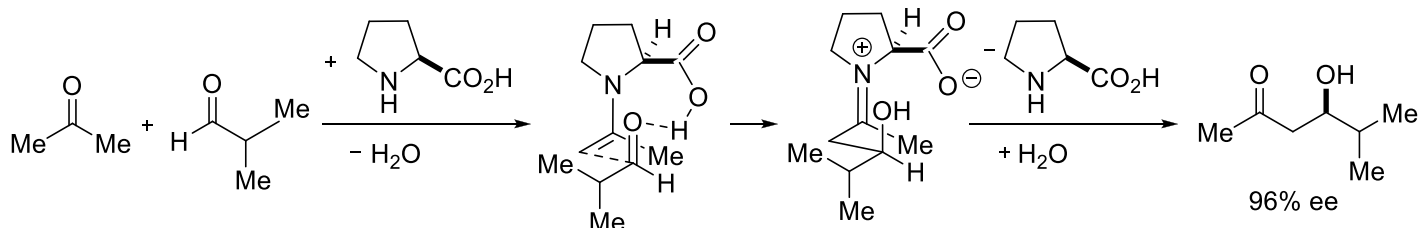

2.7.3 Conjugate Addition and the Vinylogous Principle (Michael Addition)

Vinylogous Principle

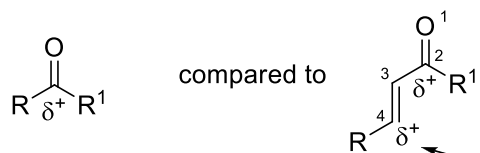

Regioselectivity

- 1,2 -Addition favored for hard nucleophile (Grignard)
- 1,4 (Michael) Addition favored for soft nucleophile (Cuprate)

Electronic properties are "transmitted" by double bond = vinylogous principle

Important Applications of Michael Addition

Synthesis of (all-carbon) quaternary centers

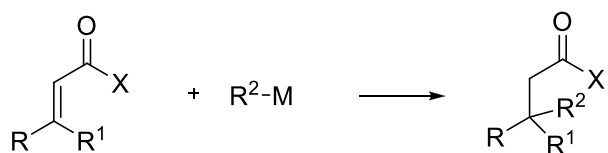

quaternary centers are generally difficult to synthesize!

Robinson annulation

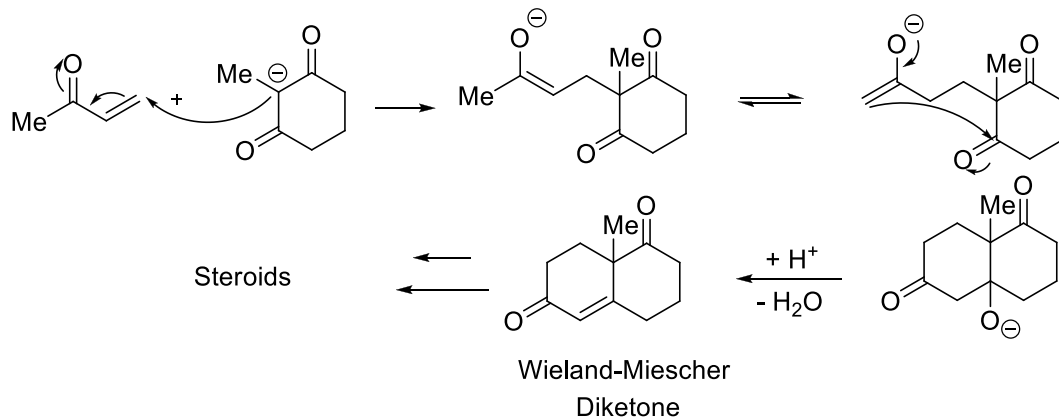

The asymmetric variation of this method is possible with proline as a catalyst (Hajos-Parrish-Eder-Sauer-Wiechert Reaction)

3. Rearrangements

3.1 Sigmatropic Rearrangements

Literature: Carey-Sundberg, A. Ch. 10.6, p. 911-951; B, Ch. 6.4-6.5, p. 552-590. Carreira, Ch. 16, p. 515-551. Evans, lectures 13-14. Bruckner, Ch. 14.5, p. 632-643.

3.1.1 [3,3] Sigmatropic rearrangements

3.1.1.1 General mechanism

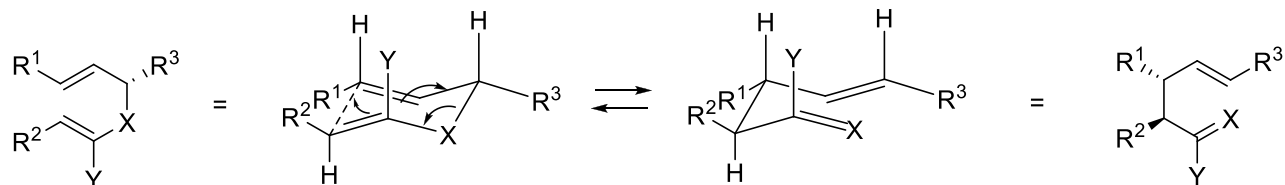

In the concerted [3,3] sigmatropic rearrangement, the electrons are re-organized between sigma and pi bonds in a 6 membered transition state. The favored transition state is most often (but not always) a chair, which is 5 kcal/mol favored over the boat transition state for the simple systems. This well-defined transition state gives an excellent transfer of stereochemistry, whereas the transition state with the bulky group is in equatorial position. Usually, the reaction has a high activation energy and is reversible, and perturbation of the system through substitution is required to have preparatively useful reactions.

Analysis of the transition state

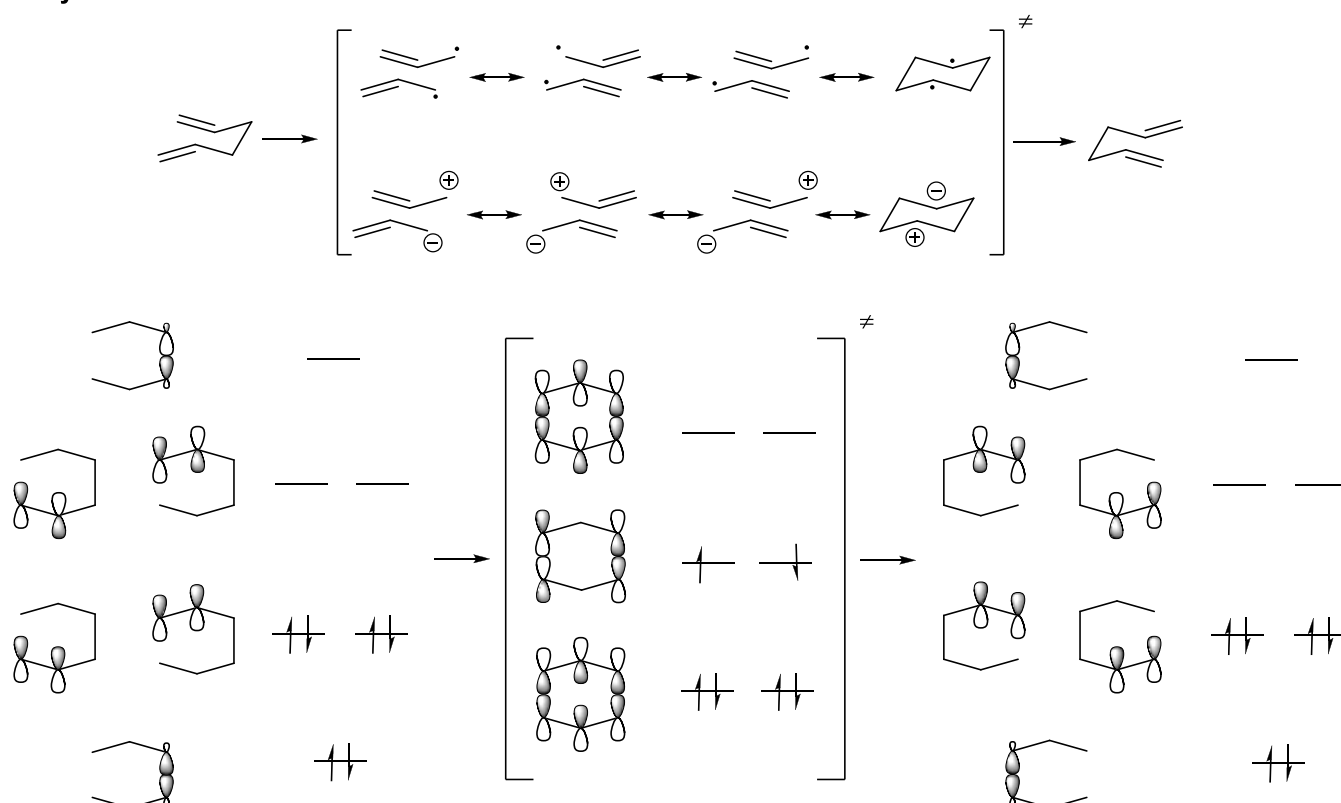

To understand the reactivity of different substrates, it is important to look on the transition state more in details. An extrem representation of the transition state is when the sigma bond is broken, either homolytically to give two allyl radicals (biradicaloids), or heterotically to give an allyl cation and an allyl anion. Recombination gives then the product. This very simple model allow to understand why the reaction is possible (stabilization through allylic delocalization) and how it could be accelerated (stabilization of the intermediate radicals, cations or anions). The "real" transition state is still concerted, but all the resonance structures contribute to its stabilization. If one (or several) of the resonance structures is particularly stabilized, then the transition state will be lowered.

A **qualitative** orbital model also allow to represent the mechanism. It is easy to understand how the reaction can be very slow, as a very stable sigma bond is lost in the transition state. The favored structure will be determined by the substitution. A **quantitative** discussion will take place in the lecture physical organic chemistry.

3.1.1.2 Cope and Oxy-Cope

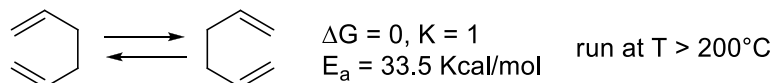

The Cope reaction is the [3,3] sigmatropic rearrangement involving only carbon atoms. The reaction is slow for the unsubstituted system. The reaction is reversible, and a thermodynamic driving force is needed to obtain a synthetically useful reaction, which does not give a mixture of product and starting material. The retron for the Cope (cyclohexa-1,5-diene) is easily recognized.

Synthetically useful methods:

A) Stabilization of the product

- Formation of more stable double bonds

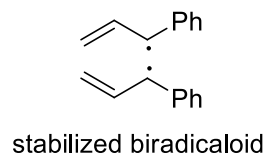
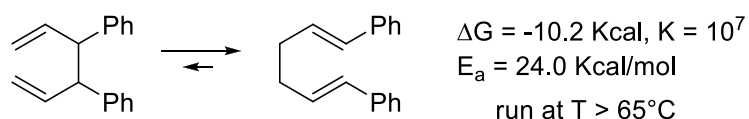

A possibility to favor the cope reactions is the formation of more substituted or conjugated double bonds. The conjugation of two phenyl groups for examples gives about 10 kcal in energy. Furthermore, the stabilization of the biradicaloid transition state by conjugation accelerate the reaction.

- **Oxy-cope**: enol-tautomerization to more stable carbonyl groups:

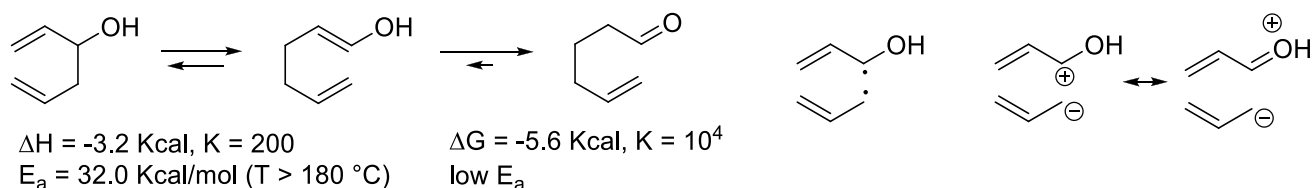

In the **oxy-cope rearrangement**, an allylic alcohol is used. The obtained enol can then isomerize to the corresponding aldehyde, and the more stable C-O double bond drives the reaction forwards. The effect on the transition state is weak: the reaction is only slightly accelerated when compare to the cope reaction. The small acceleration can be explained by stabilization of the radical or the carbocation by the heteroatom.

- **Anionic oxy-cope**

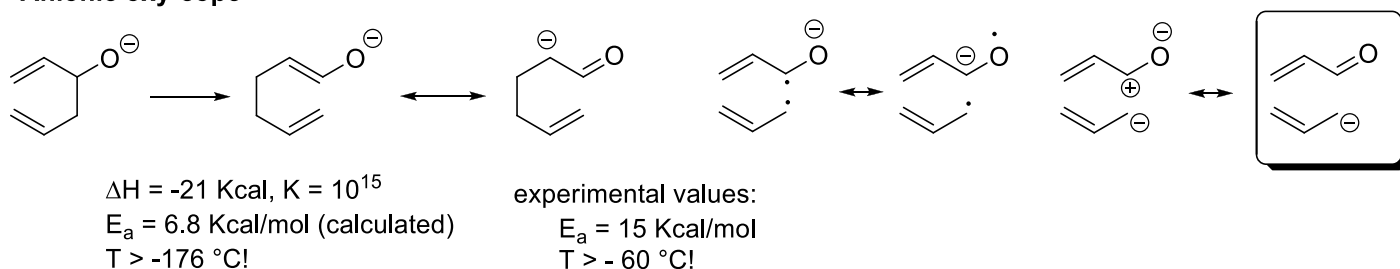

An important discovery for practical applications was the **anionic oxy-cope reaction** by Evans. The deprotonated alcohols reacts up to 10^{17} times faster and the rearrangement is now irreversible. The differences between the calculated values and the experimental ones are explained by the fact that the calculation are for the naked anion in the gas phase. In reality, there is stabilization by the solvent and the counter cation. In fact, the acceleration goes in the order $\text{K}^+ > \text{Na}^+ > \text{Li}^+$. With Li^+ , which strongly coordinates to O^- , there is nearly no acceleration. The reactions can be further accelerate by cation-binding ligands, such as crown ethers. The irreversibility is explained by the high stability of the enolate anion. The acceleration by the stabilization of the allyl intermediates. In particular, the cation intermediate is now perfectly stabilized and the reaction becomes highly asynchronous.

Synthetic considerations

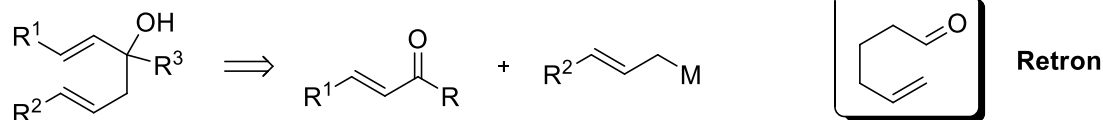

A further advantage of the oxy-cope rearrangement is the easier synthesis of the starting materials, for example via classical addition of nucleophiles unto carbonyl compounds. In the retrosynthetic direction, the reaction is more difficult to recognize. Because of the tautomerization, the classical 1,5-hexadiene of the Cope rearrangement is not visible anymore, and we have now a 1-oxo-hexa-5-ene as retron.

Stereoselectivity:

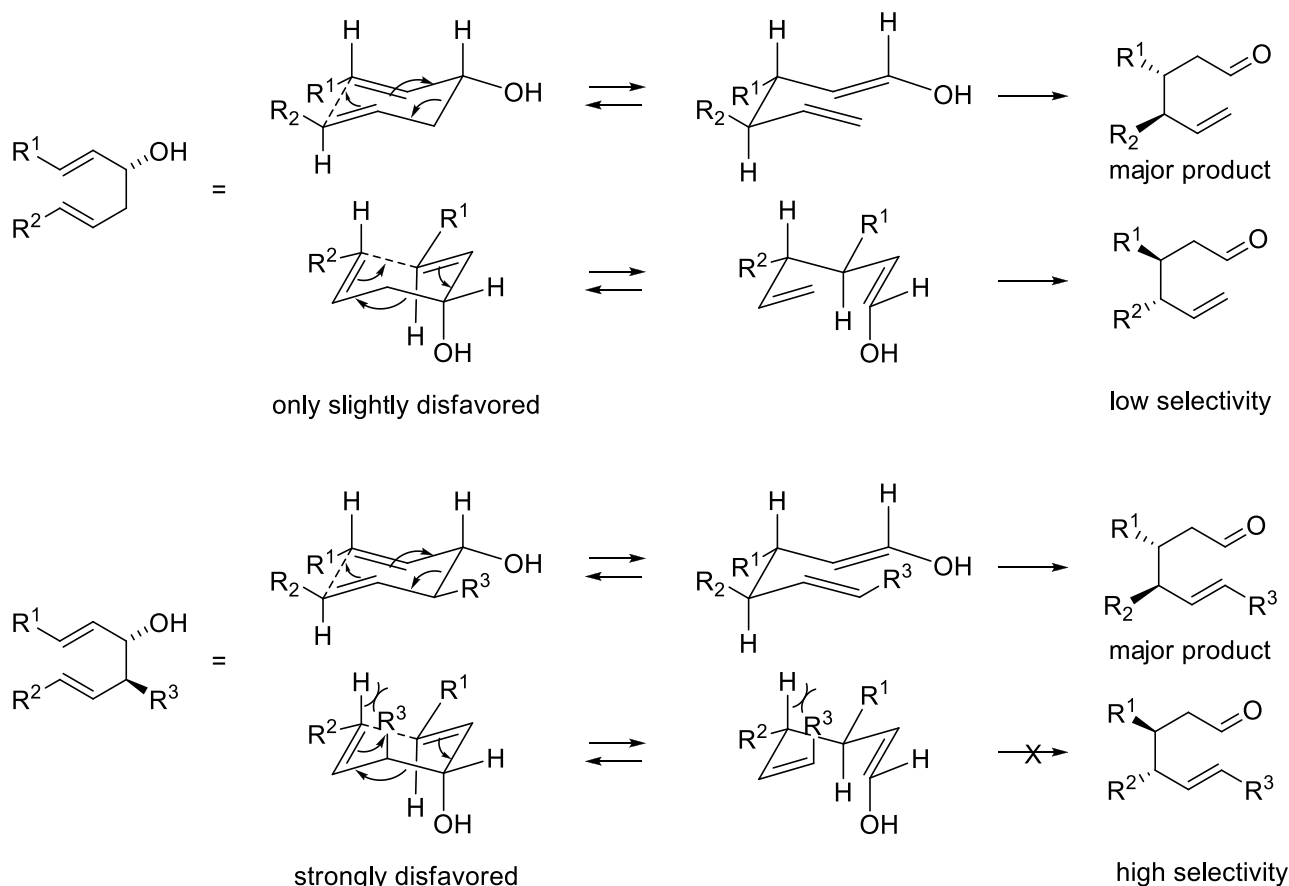

A disadvantage of the oxy-cope reaction is the small size of the hydroxy group (A value: 0.6 Kcal/mol), which leads to low selectivity. A second more bulky substituent is needed to reach high selectivity.

B) Destabilization of the starting material

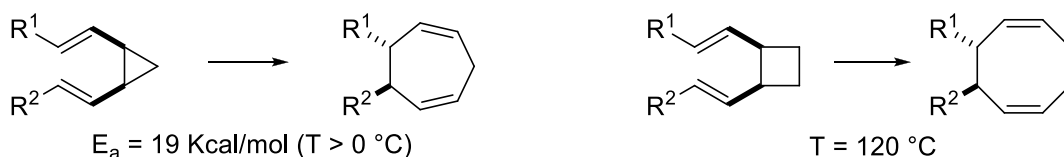

Another possibility to make the cope rearrangement irreversible is to destabilize the starting material. A classical way to do that is to introduce ring strain in the starting material. For example, the *cis*-divinylcyclopropane rearranges very easily to the corresponding cycloheptadiene. The corresponding *trans*-divinylcyclopropane cannot form a cyclic transition state and needs high temperature to rearrange.

3.1.1.3 Claisen-Type Rearrangements

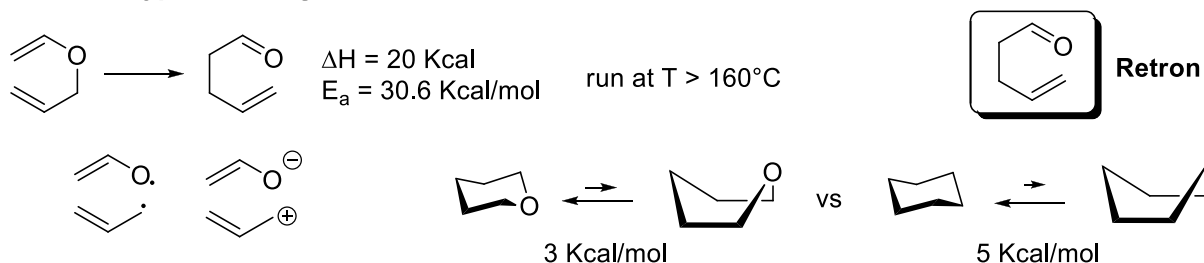

In the Claisen-type rearrangements, one of the carbon atoms is replaced by an oxygen. The formation of a C-O pi bond, which is 20 Kcal more stable than the C-C pi bond, makes the reaction irreversible. The original Claisen was for allyl vinyl ethers. The mechanism is similar to the cope, but the reaction goes at slightly lower temperature, due to the possible stabilization of the transition state in an asynchronous enolate-allyl cation way. The transition state is also a chair transition state, but the difference between chair and boat is smaller, as O is less encumbered than a CH_2 group. The retron for this reaction is a 1-oxo-pent-4-ene.

Synthesis of allyl-vinyl ether

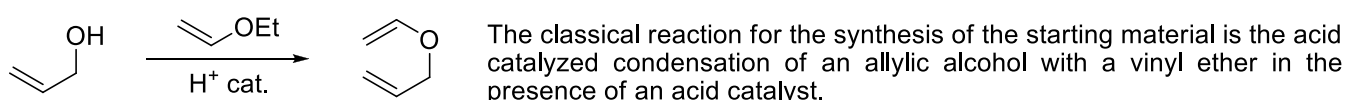

Diastereoselective synthesis of olefins

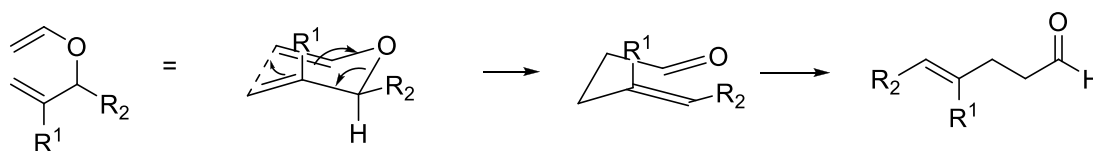

An important application of the Claisen rearrangement is the stereoselective synthesis of olefins, based on the chair transition state.

Synthetically important variations of the Claisen rearrangement

A/ Aromatic Claisen

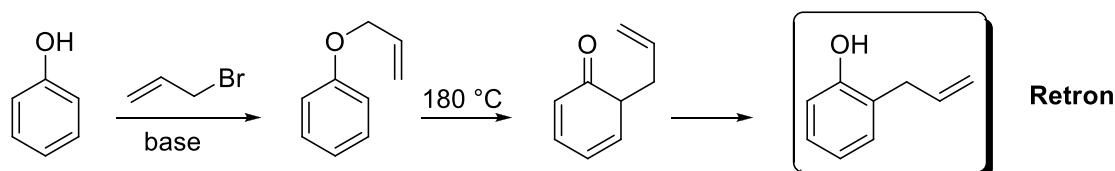

The aromatic Claisen rearrangement is often used for the synthesis of ortho-allyl phenols. The starting materials are easily accessed using a Wilkinson ether synthesis. The obtained α -allyl carbonyl then rearomatized to the phenol.

B/ Rearrangement leading to the ester/acid oxidation state

B1 Johnson-Claisen ortho-ester rearrangement

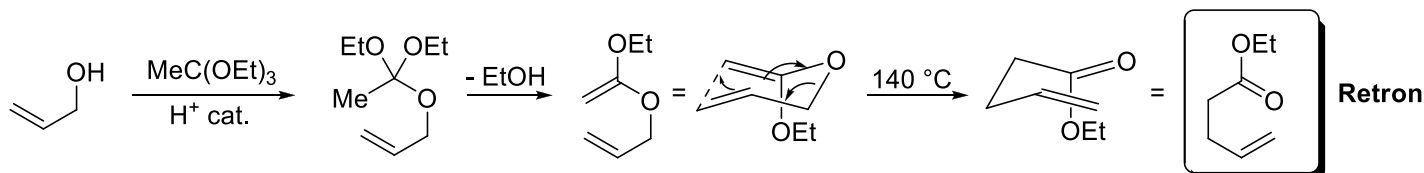

The Johnson method begins with the condensation between an allyl alcohol and an ortho ester. After loss of ethanol, the formed ketene acetal rearranges to form the ester product. The reaction proceeds via a chair transition state and uses easily available starting materials, but is usually limited to methyl substituted orthoesters.

B2 Eschenmoser-Claisen ortho-ester rearrangement

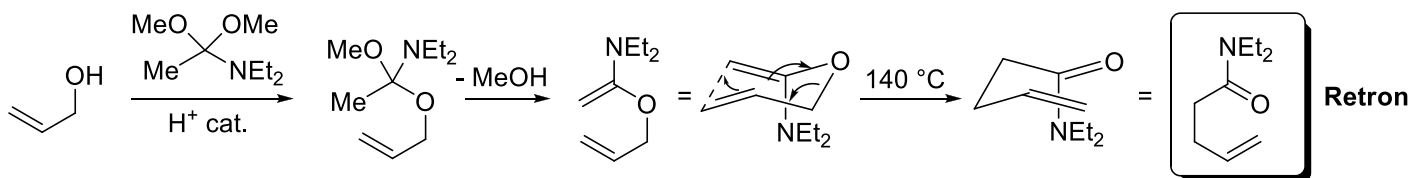

The Eschenmoser method is very similar to the Johnson one, but lead to the formation of the amide instead of the ester. An advantage of the method is the bulky NEt_2 group in pseudo axial position in the transition state: this lead to very strong $A_{1,3}$ interactions and higher selectivity than for the Johnson rearrangement.

B3 Enolate and Ireland-Claisen rearrangement

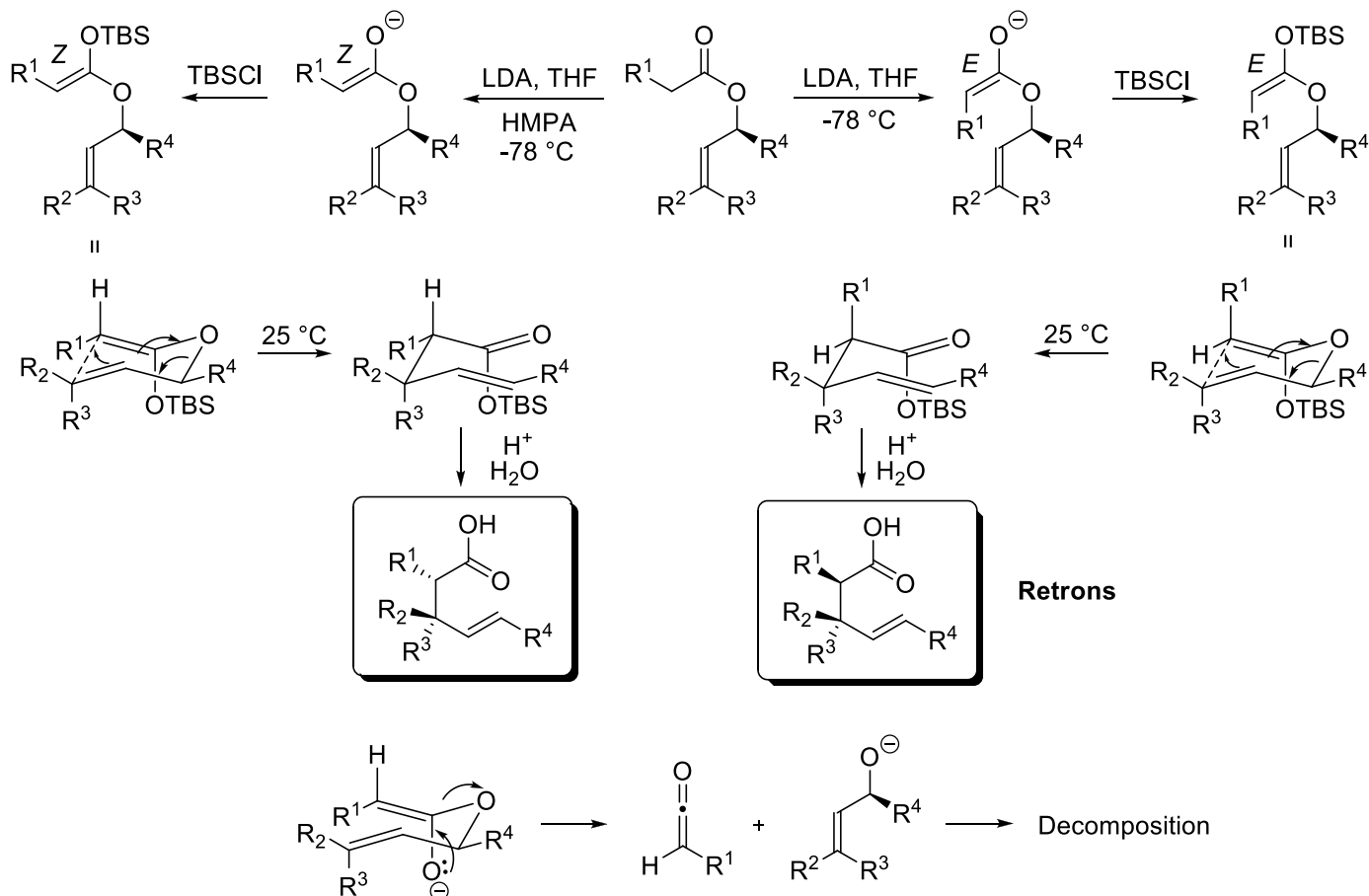

The Ireland-Claisen is one of the most useful [3,3] sigmatropic rearrangements in synthesis. It gives access to the corresponding carboxylic acids. Key features of this reaction are:

- The bulky group at the allylic position is in equatorial position, this allows the transmission of the absolute stereochemistry of the starting material to the product.
- The relative stereochemistry is controlled by the geometry of the double bond and the enolate. Ireland developed efficient methods to control the stereoselective formation of enolates (see next page for a repetition).
- The reaction is not very sensitive to steric bulk and is consequently often use for the synthesis of quaternary all - carbon centers, which are difficult to access using other methods.
- The rearrangement of free enolates is even faster. However, decomposition via the ketene is observed in this case, and the yields are lower than with silyl enolates

Deprotonation with LDA: *cis* vs *trans* selectivity

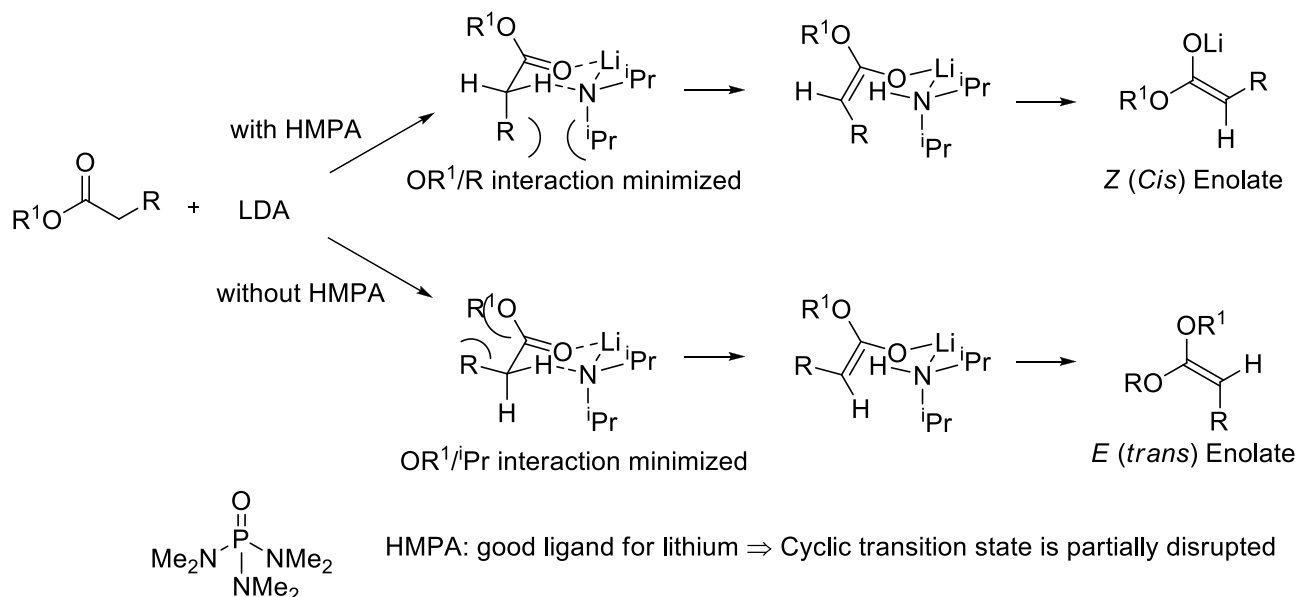

For the Ireland-Claisen rearrangement, it is very important to control the geometry of the ester enolate. Without HMPA, a tight six-membered transition state is formed and the A^{1,3} interaction between the R group and the ⁱPr group on nitrogen are strong. This interactions are minimized and the *E* enolate is formed. HMPA coordinates to Li and makes the transition state less tight. The interaction between R and OR¹ (A^{1,2}) are now dominating, and the *Z* enolate is formed.

Special case: rearrangements on cyclic systems

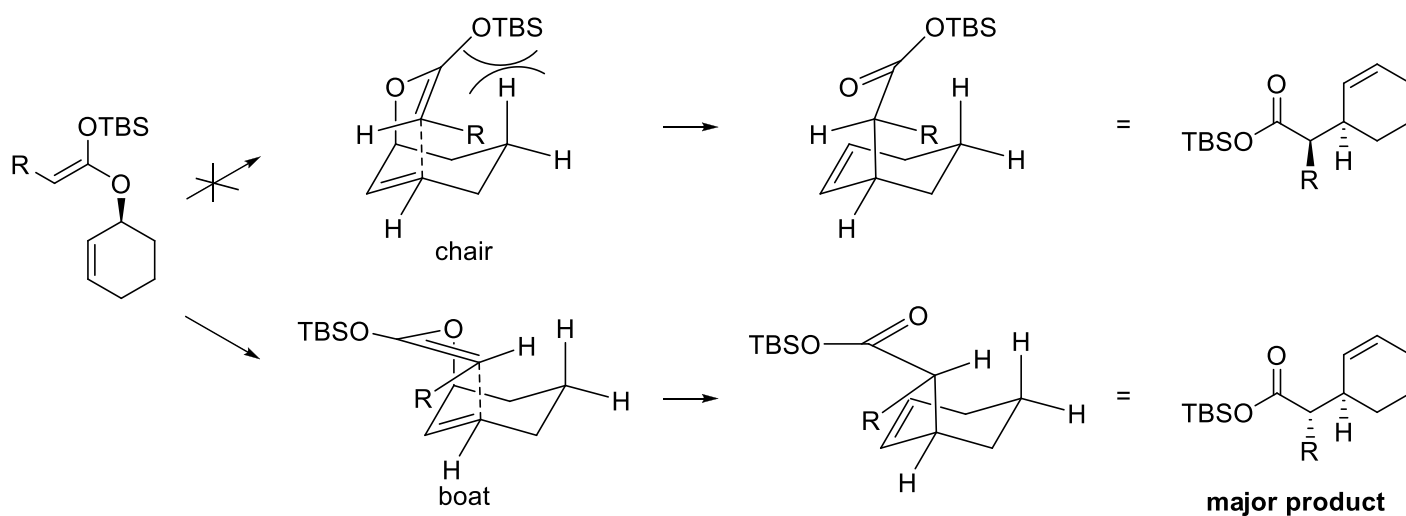

Care is needed for the analysis of the transition state of cyclic substrates. In fact, new steric interactions are now possible with the existing cycle in the transition state. In particular in Claisen-type rearrangement, the inherent difference between chair and boat is not so important. If the new steric interactions are strong, as shown here, the boat transition state can be favored.

B4 Carroll-Claisen rearrangement

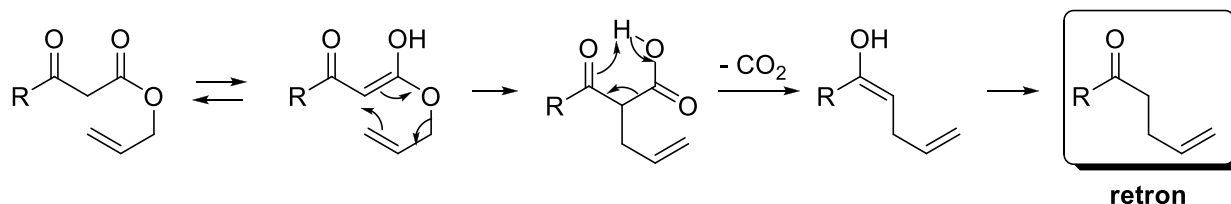

In the Carroll variation, the starting material is a keto-ester. The advantage is that the enol form can be accessed without base. Heating then leads to rearrangement. Under these conditions, the product usually decarboxylates to form the ketone. It is also possible to run the reaction under basic conditions at lower temperature to prevent decarboxylation.

3.1.1.3 Other heterocyclic variations

A/ aza-Cope and aza-Claisen

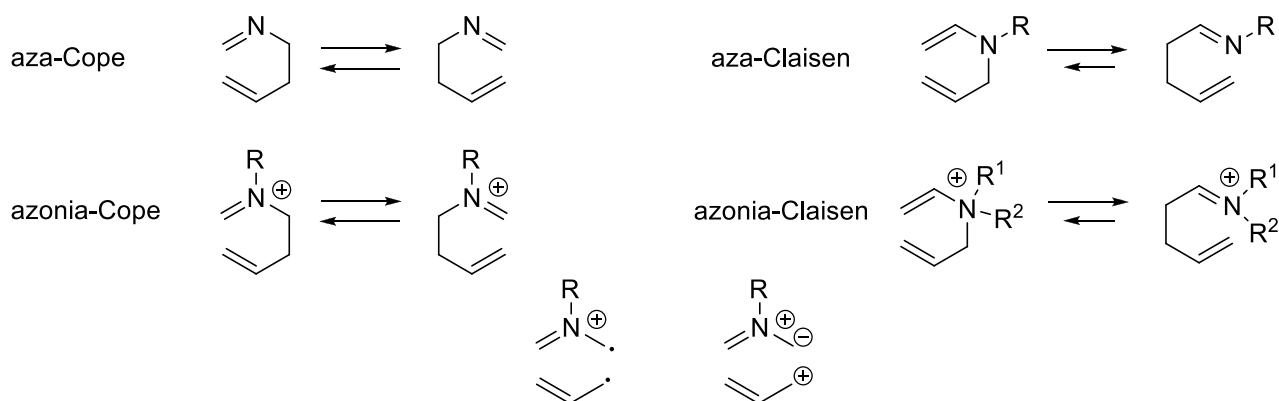

The introduction of nitrogen into the substrate is also possible. The aza-Cope process is thermodynamically neutral and has the same problems than the Cope. The aza-Claisen, in contrast to the Claisen rearrangement, is also nearly thermodynamically neutral, because of the similar bond strengths of the C-C and the C-N double bonds. An interesting effect on the kinetic is seen in the charged intermediates: these react much faster, because of the stabilization of the asynchronous transition state through charge interactions.

oxy-azonia-Cope (aza-Cope)-Mannich sequence

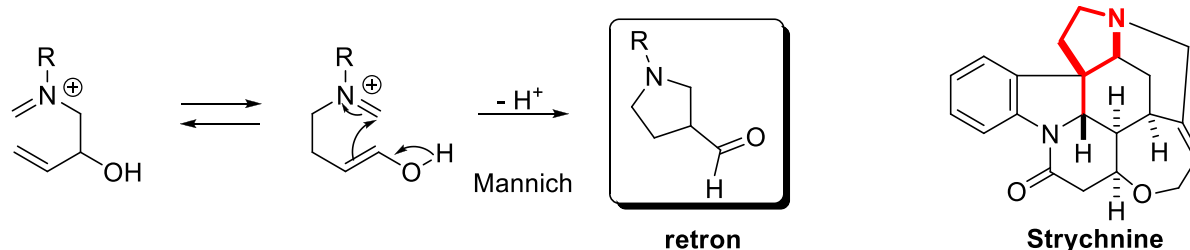

As for the cope, the problem of equilibrium can be solved by the formation of a carbonyl group. A particularly elegant solution is the direct use of the formed enol in a subsequent reaction. Overman developed the aza-oxy-Cope-Mannich sequence, whereas the formed enol reacts with the iminium via an intramolecular reaction. The formed 3-carbonyl pyrrolidine is a very useful building block for the synthesis of complex natural products, such as strychnine. This example will be discussed in the lecture.

B/ Overman rearrangement: imidates

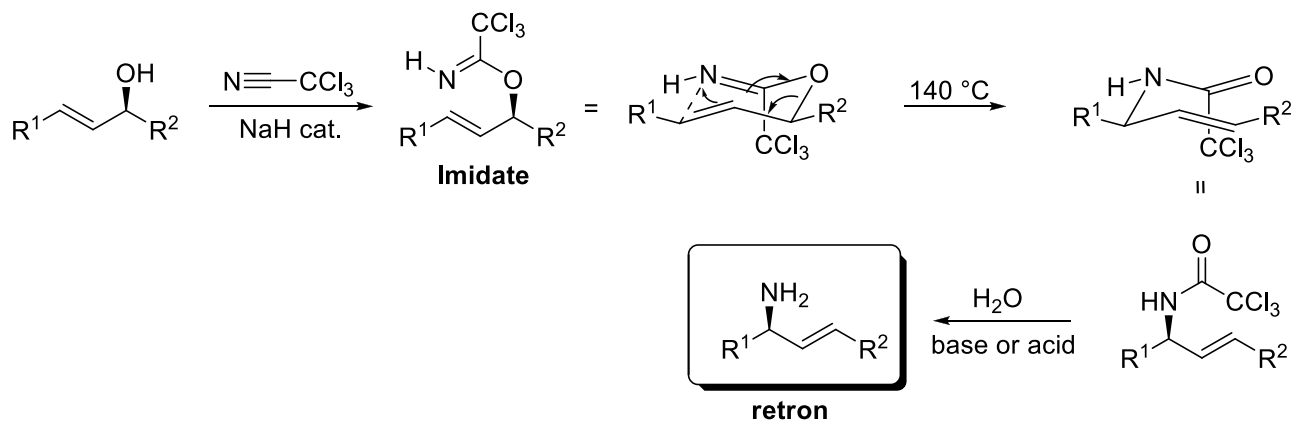

The rearrangement of imidates has been developed by Overman for the synthesis of allylic amines. Starting from easily accessible allylic alcohols, reaction with trichloro acetonitrile gives the imidate. The sigmatropic rearrangement proceeds with high transfer of chirality at $140\text{ }^\circ\text{C}$. Recently, catalysts have been developed to run this reaction at lower temperature. The obtained amide is easily deprotected to form the allylic amine.

C/ Fischer Indole synthesis

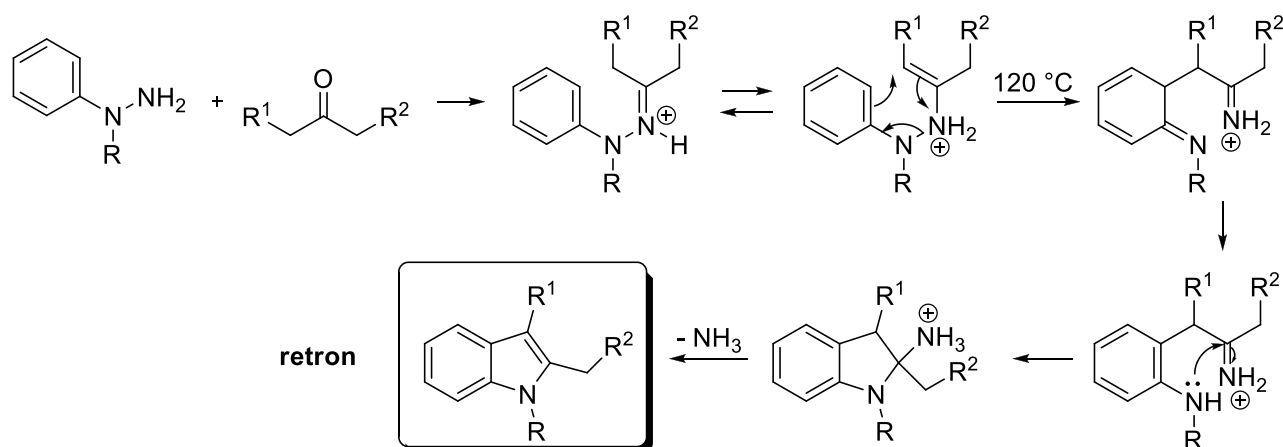

The synthesis of indoles starting from hydrazines and ketones has been discovered by Emil Fischer in 1883. It is still today one of the most important synthesis of indoles, which are very important heterocycles in pharmaceutical chemistry. The reaction begins with the condensation of the ketone with the hydrazine to form the hydrazone. The "iminium" is then in equilibrium with the enaminium. At this point [3,3] sigmatropic rearrangement becomes possible. The obtained product then rearomatized. The last step of the reaction is an intramolecular attack of the aniline nitrogen followed by elimination of ammonia. The fact that ammonia is lost makes retro-synthesis particularly challenging in this case.

In this lecture, only the synthetically most relevant examples have been presented. Of course, there are many other possibilities to substitute heteroatom in the sigmatropic rearrangement, but the mechanistic bases stay the same.

3.1.2 [3,2] Rearrangements and others

[3,2] rearrangement: general mechanism

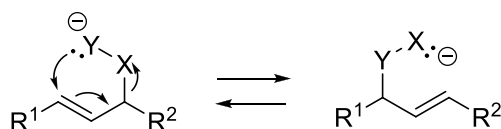

Resonance structure of transitions state:

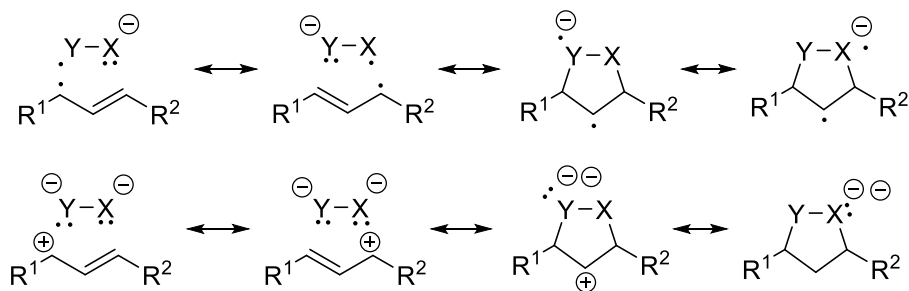

In the [3,2] sigmatropic rearrangement, one of the double bond present in the [3,3] system is replaced by a pair of electron determined mostly by the more stable location for the electron pair. Again, either biradicaloid or charged resonance struc

Stereochemistry

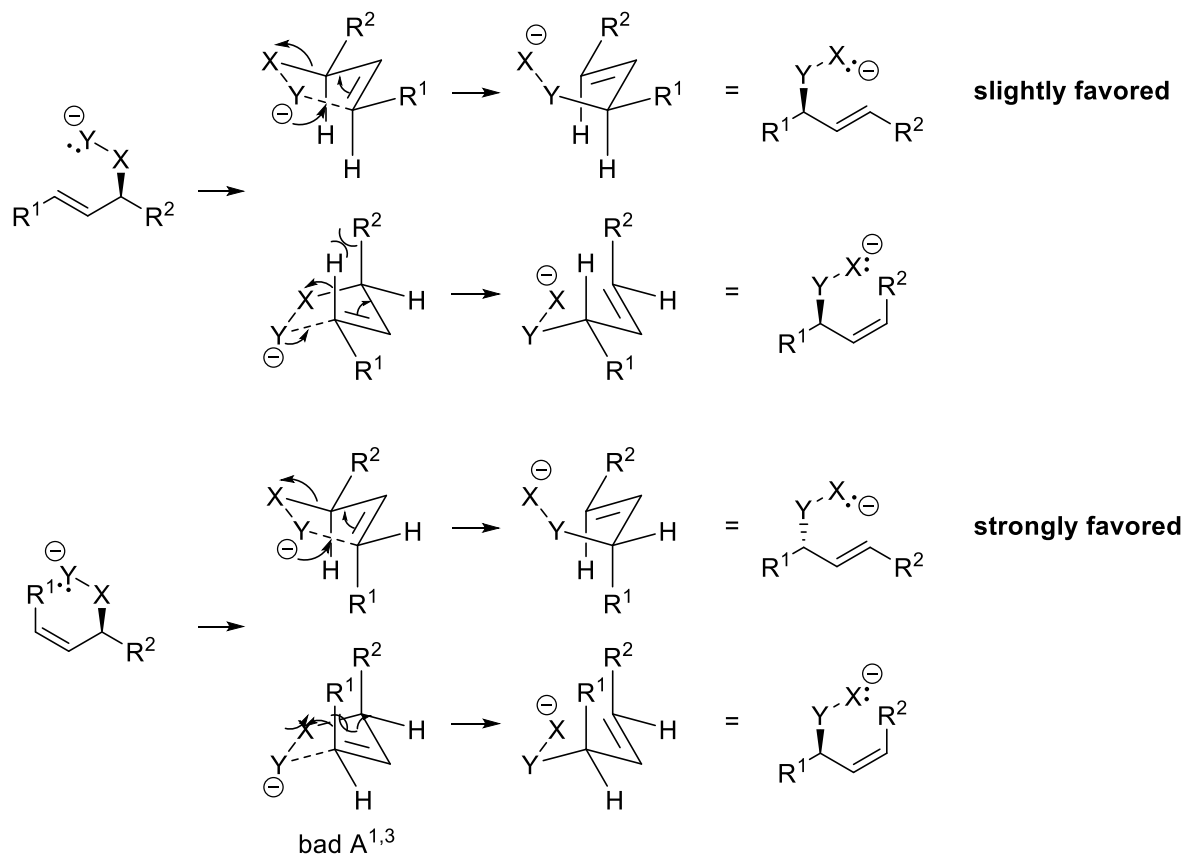

The transition state for the [3,2] rearrangements is usually an envelope. Like for the chair transition state, the pseudo. Consequently the selectivity are lower for the olefin geometry of the product when starting from *E* olefins. In the case of *Z* to the *Z* olefin.

Synthetically important examples

A/ [3,2] Wittig rearrangement

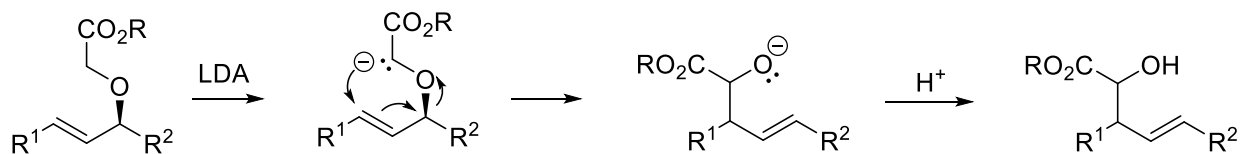

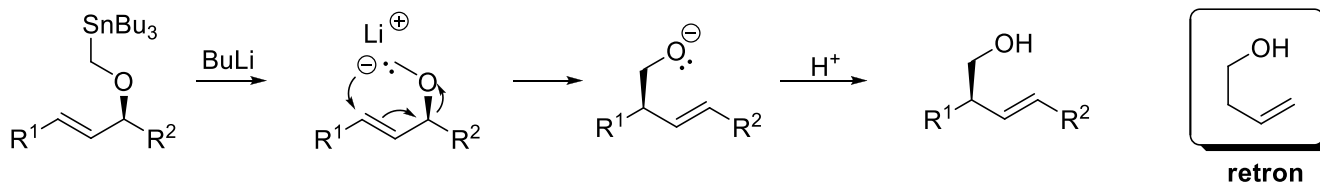

The Wittig rearrangement ($Y = C$, $X = O$) is probably the most often used [3,2] rearrangement. It is thermodynamically favorable, as the electron-pair is transferred from carbon to a more electronegative oxygen. If an electron-stabilizing group like an ester is present, deprotonation with a base allow the generation of the carbanion. The unsubstituted carbanion is difficult to access directly: in this case, a transmetalation from Sn can be used. The general retron for the Wittig rearrangement is an homo-allylic alcohol.

B/ Evans-Mislow

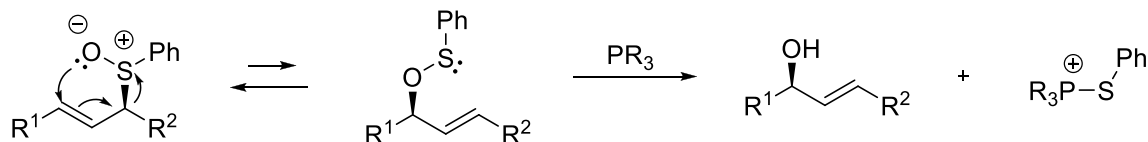

In the Evans-Mislow rearrangement ($Y = O$, $X = S$), the starting material is a sulfide. There is no strong thermodynamical driving force for this reaction. However, the obtained sulfide ether is easily reduced with phosphine, which allow driving the reaction to completion by formation of the allylic alcohol.

C/ Sommelet-Hauser

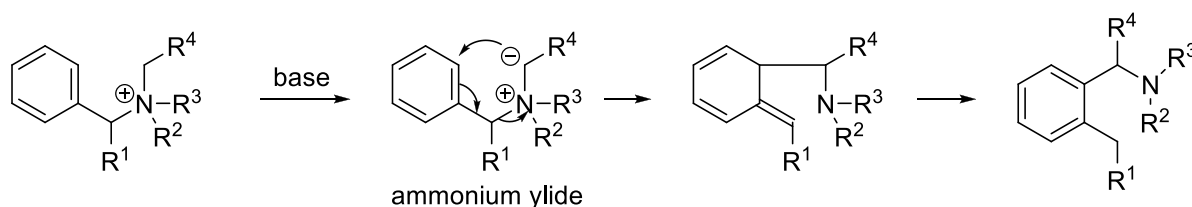

In the Sommelet-Hauser rearrangement ($Y = N$, $X = C$), the relatively acidic alpha position of an ammonium is deprotonated. After [3,2] rearrangement and rearomatization, a new benzylic amine is obtained.

[1,X] Shifts

[1,X] shifts usually occurs via reactive intermediate (see section 3.2). An exception are the H shift over pi systems, which are particularly interesting for their mechanistic relevance.

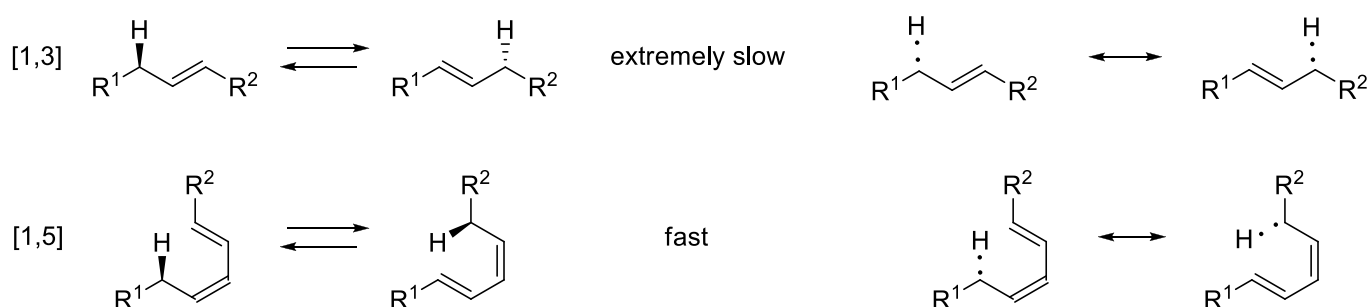

The [1,3] shift is extremely slow and usually not observed with H. If occurring, the shifting atom is coming on the opposite face (antara shift). In contrast, the [1,5] shift is fast, and the hydrogen is transferred to the same face of the pi system. It is not possible to rationalize these results by Lewis structure only.

[1,3]

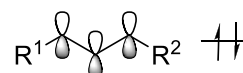
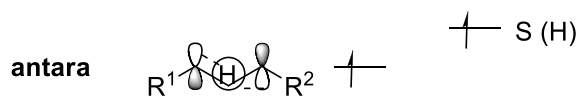
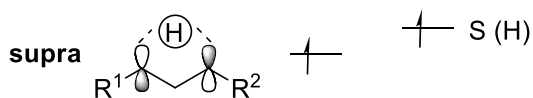

wrong phase!

Correct phase, but overlap difficult

[1,5]

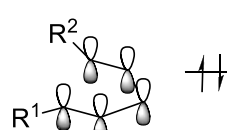
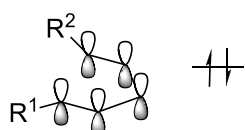
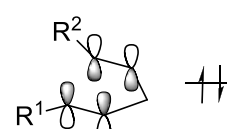
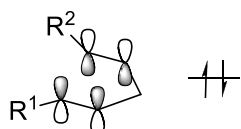
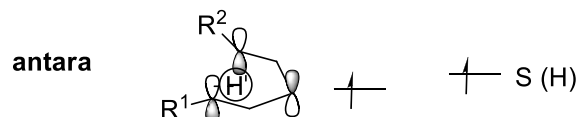
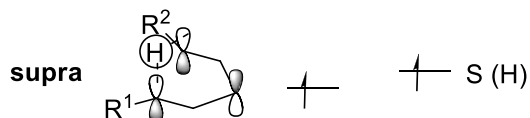

correct phase

wrong phase

It is only with the analysis of the symmetry/phase of the orbitals that the reasons for the selectivity in the H-shift become clear. The symmetry of the SOMO of the allylic radical prohibits a supra (same face) transfer of the hydrogen. The antara (different face) transfer is correct from the point of view of phase, but very difficult to achieve due to the small size of H and bad orbital overlap. For the 1,5 shift, the phase/symmetry is correct for a supra shift. The reaction is easy, as long as the correct geometry can be accessed. Logically, the [1,7] shift will be again an antara shift: in this case, good overlap is possible depending on the structure of the substrate. These observations were a strong confirmation for the **Woodward-Hoffmann** rules (see physical organic chemistry lecture).

Simplified version of the Woodward-Hoffmann rules:

Reaction is allowed if there is a correct phase overlap/ symmetry of the orbitals

3.2 Rearrangements via Reactive Intermediates

Literature: Carey-Sundberg, A. Ch. 3.4, p. 297-332; B, Ch. 10.2-10.2, p. 851-956. Evans, lectures 31-32, 34-35 (in part). Bruckner, Ch. 14.1-14.4, p. 595-632.

The most important reactive intermediates for rearrangements are carbocations and carbenes/nitrenes. However, there are also some rearrangement via anions or radicals. Most of the considered rearrangements are 1,2 shifts.

3.2.1 Cationic rearrangements

3.2.1.1 On Carbon

1,2-Alkyl Shift: Wagner-Meerwein Rearrangement

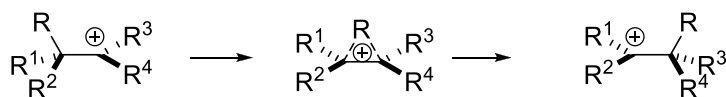

2 electrons - 3 centres
transition state

migration order: aryl/H/vinyl > tertiary alkyl > cyclopropyl > secondary alkyl > primary alkyl

The alkyl (or proton) shift to carbocations is a classical reaction in organic chemistry. The transition state contains 3 centers 2-electrons, an "hypervalent" situation for the migrating group. This kind of non-classical bonds will be discussed in details in physical organic chemistry. The best cation-stabilizing group is migrating.

Stability of carbocations: Hyperconjugation

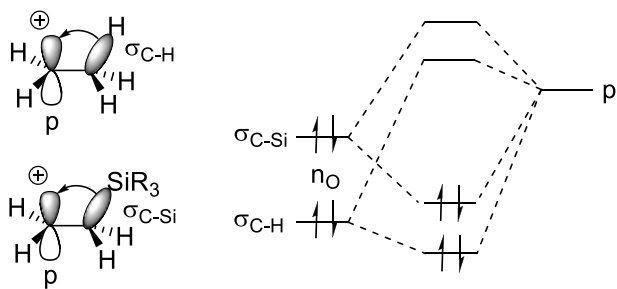

The stabilization of carbocations through hyperconjugation can be considered as a "partial 1,2-shift"/ partial hypervalency. Electron density is transferred from the adjacent sigma bond to stabilize the charge. The hyperconjugation explain the relative stability of carbocations (tertiary > secondary > primary). The C-Si bond is more electron-rich than the C-H or C-C bond, and the carbocation is particularly well stabilized in this case (**beta effect of silicium**).

Synthetically important 1,2-shifts

In principle, 1,2-alkyl/proton shifts are reversible, as a new carbocation is formed in the reaction. If one of the two carbocations is much more stable or is consumed in the reaction, the process can become practically useful.

A/ Pinacol and semi-Pinacol rearrangements

Pinacol Rearrangement

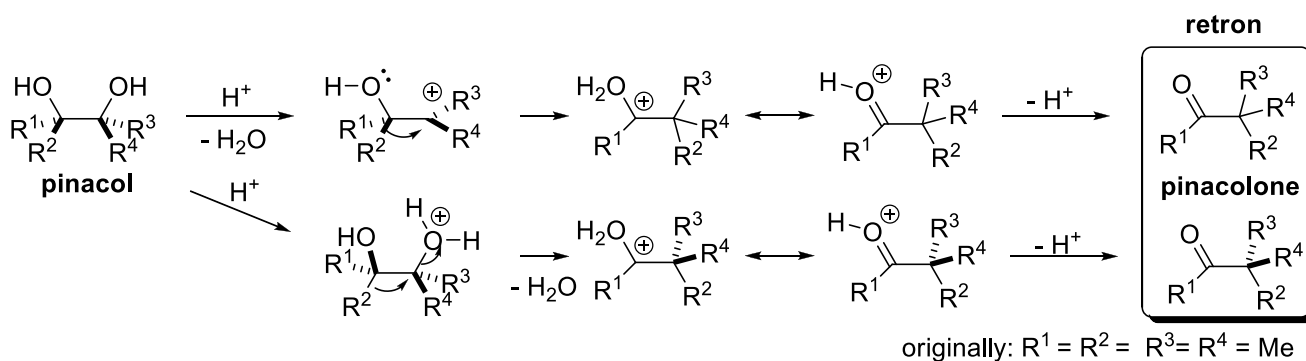

The original pinacol rearrangement is the transformation of 2,3-dimethylbutan-2,3-diol (pinacol) to methyl *tert*-butyl ketone (pinacolone). The reaction more generally describes the rearrangement of vicinal diols to ketones under acidic conditions. The driving force for the reaction is the formation of a more stable oxonium cation, which gives the carbonyl after deprotonation. Depending on the conditions, the reaction can proceed either via the formation of a first isolated carbocation, which leads to a loss of the stereochemical information, or through a partially synchron mechanism. In the latter case, the migrating group is anti-periplanar to the leaving group (interaction with the σ^* orbital of the C-O bond). A major disadvantage of the pinacol rearrangement is the low regioselectivity sometimes observed in the first step.

Semi-Pinacol rearrangements

Same Starting from:

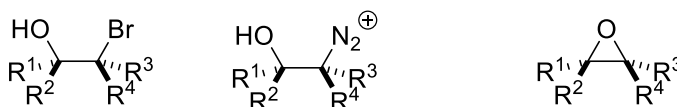

In the semi-pinacol rearrangement, one of the two hydroxy groups has been replaced by a better leaving group. This allow to control the formation of the first carbocation and the regioselectivity of the reaction. An especially useful variation is the Tiffeneau-Demjanov rearrangement: the reaction starts from 1,2 amino alcohol an begins with nitrosation of the amine. After dehydration, a diazonium is obtained and semi-pinacol rearrangement gives the ketone. Another possibility is two start from an epoxide: opening in presence of a Brønsted or Lewis acid then generates the carbocation.

Tiffeneau-Demjanov rearrangement

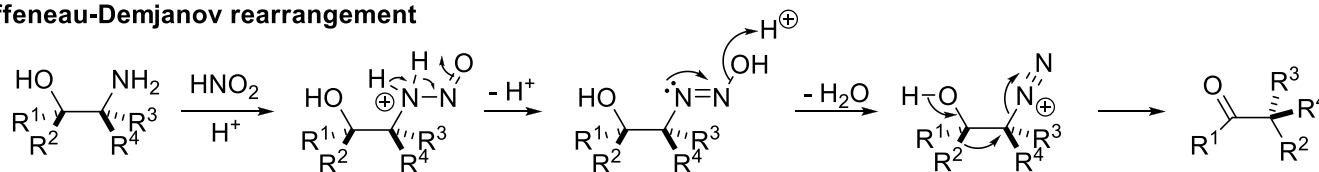

Prins-Pinacol cascade

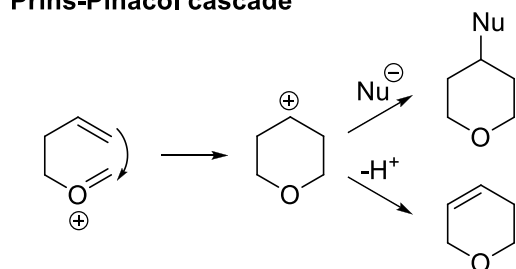

The prins reaction

The Prins reaction is the cyclization of double bond onto carbocation. A special case is the cyclization on oxonium, which are two reactive to make a sigmatropic rearrangement. The resulting carbocation can either form a double bond via elimination, or be trapped by a nucleophile

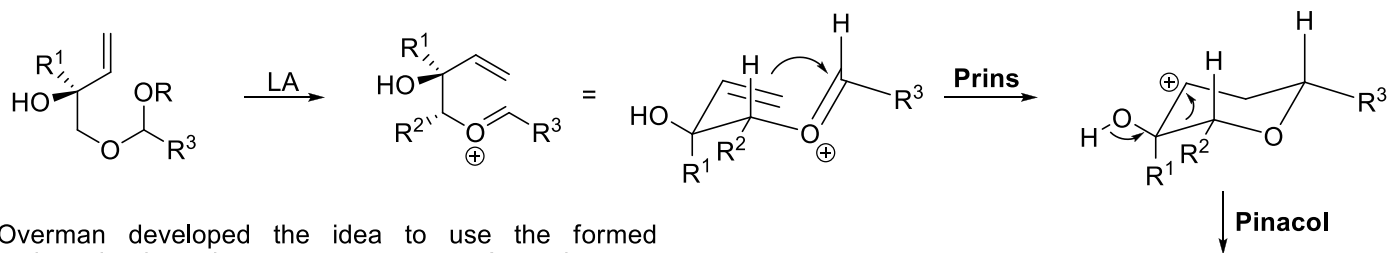

Overman developed the idea to use the formed carbocation in a pinacol rearrangement. A good way to generate the oxonium is from acetals in the presence of a Lewis acid. The transition state for the Prins cyclization is a chair, with the most sterically encumbered groups in equatorial position. After cyclization, the migration of the ring bond is favored and leads to a five membered ring. The Prins-Pinacol sequence allow the stereoselective synthesis of 3-carbonyl tetrahydrofurans.

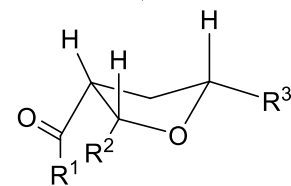
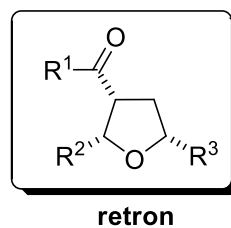

B/ Benzilic acid rearrangement

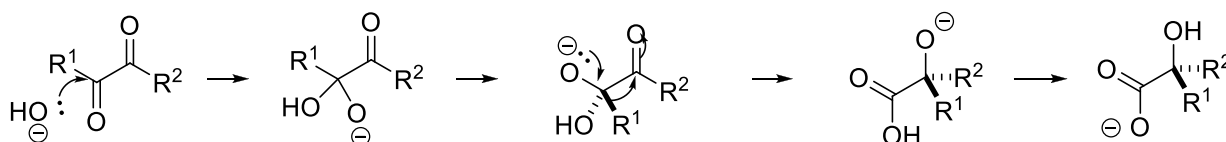

The benzilic acid rearrangement is the transformation of diketones into the corresponding alpha-hydroxy acid. The reaction is initiated by the nucleophilic addition of hydroxide onto one of the ketones. The 1,2-shift this time takes place towards an electrophilic carbonyl center instead of a carbocation. The formed alkoxide can then deprotonate the acid intramolecularly to form a much more stable carboxylate, which drives the reaction forwards.

3.2.1.2 "Cationic" rearrangements on heteroatoms

A/ Baeyer-Villiger

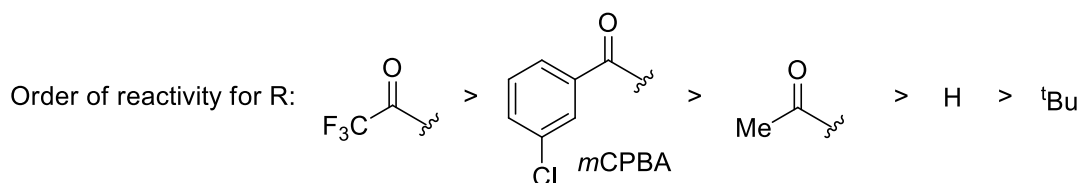
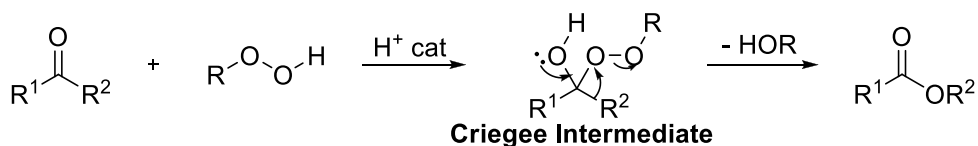

The Baeyer-Villiger oxidation is the transformation of a ketone to the corresponding ester. The reaction begins with the acid-catalyzed formation of a mixed acetal with a peroxide (the Criegee intermediate). There is then a 1,2-shift onto the electron-deficient oxygen with release of an alcohol or acid. The group that stabilized best the positive charge migrates. The more reactive reagents for the Baeyer-Villiger are the electron-deficient peracids, as they are able to catalyze the formation of the acetals and form a better leaving group for the 1,2-shift. Peroxides can also be used, but a Lewis or Brønsted co-catalyst is needed in this case.

special case: synthesis of lactones

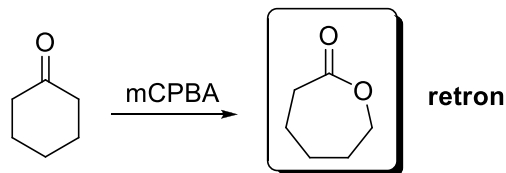

A particular useful case of the Baeyer-Villiger is the transformation of cyclic ketones to lactones. It is important to see that esters and lactones are not reactive enough to be further oxidized. Aldehydes also react to form the formates, but the formates are usually unstable and are decomposed to the alcohols.

B/ Oxidative work up of hydroboration

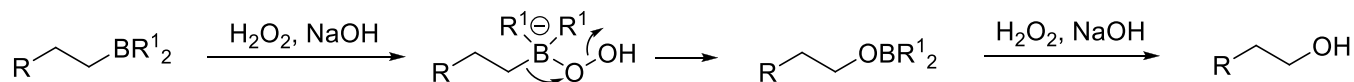

The oxidation of boranes to alcohols is another classical reaction that proceeds via 1,2-shift onto electrodeficient oxygen.

C/ Beckmann rearrangement

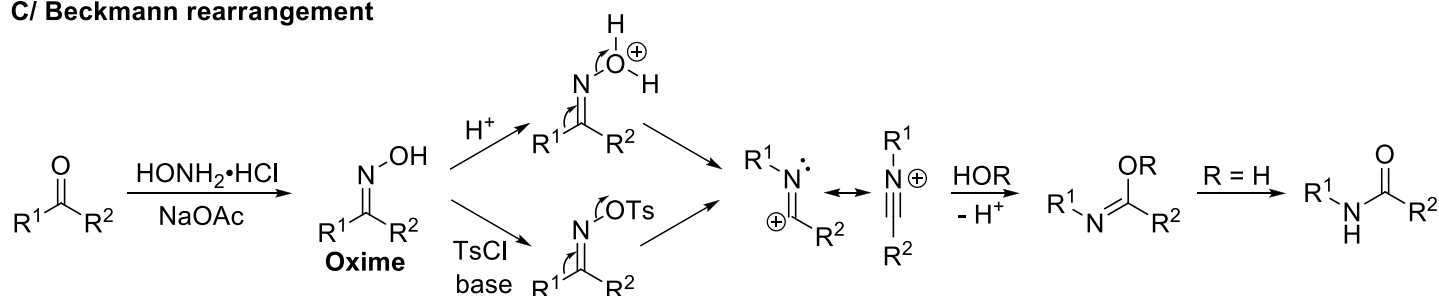

The Beckmann rearrangement is the synthetic equivalent of the Baeyer-Villiger oxidation for amide formation. The reaction begins by condensation of the ketone with hydroxylamine hydrochloride in the presence of a weak base. The resulting oxime is then activated, either by acid or by tosylation. There is then a 1,2-shift of the electron-deficient nitrogen. The formed carbocation is stabilized by the nitrogen. Nucleophilic attack of water or an alcohol then gives the imidate. In the case of water, the imidate tautomerizes to the more stable amide. An important feature of the Beckmann rearrangement is the stereocontrol of the 1,2-shift: because of the rigid structure of the oxime, the substituent *trans* to the leaving group is migrating.

Special case: synthesis of lactams

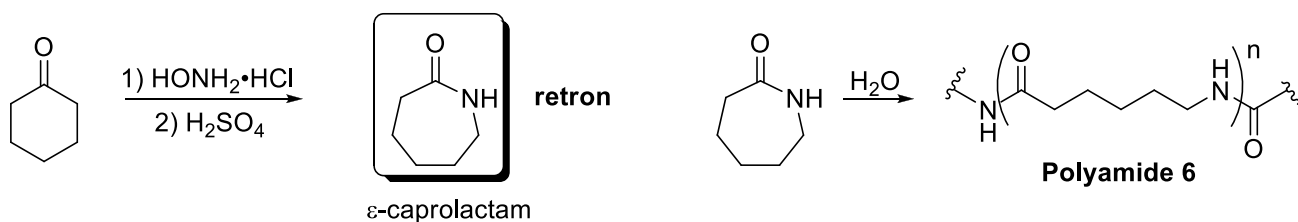

The Beckmann rearrangement is often used for the synthesis of lactams. For example, the transformation of cyclohexanone to ϵ -caprolactam is a multi-ton process. ϵ -caprolactam can then be polymerized to polyamide 6 in the presence of water, which has properties similar to Nylon.

3.2.1.3 Dissociative Rearrangements

A/ Pummerer rearrangement

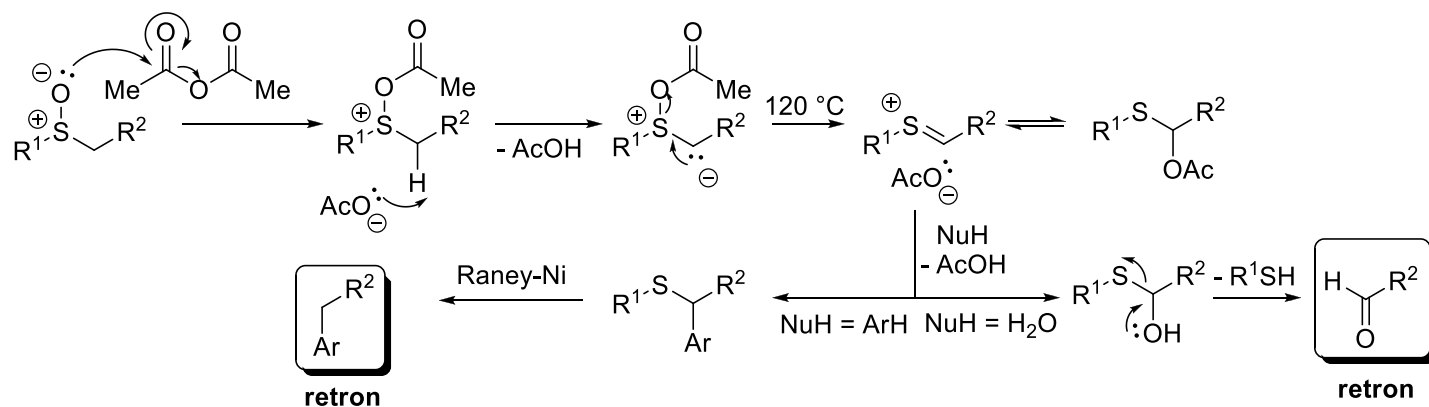

The Pummerer rearrangement is formally the rearrangement of an acyloxysulfonium salt to the acyloxy thioacetal. It is not a concerted process, however. The acyloxysulfonium salt is first generated by treating a sulfoxide with acetic anhydride or another activating agent (trifluoroacetic anhydride, acetyl chloride, trifluoromethanesulfonic anhydride,...). These salts are unstable and generate a sulfonium ylide by loss of the conjugated acid. Upon heating (the temperature is dependent on the leaving group ability: acetate, 120 °C; trifluoroacetate: 80 °C). A sulfonium is generated, which is in equilibrium with the corresponding acyloxy thioacetal. The sulfonium is very electrophilic and reacts with nucleophiles. With water, the obtained hemi-acetal further loses the thiol to form an aldehyde. The first important uses of the Pummerer reaction is consequently the transformation of sulfoxides into aldehydes. With other nucleophiles, typically electron-rich aromatic groups such as indoles or anisoles, the obtained intermediate is stable and sulfur can be removed with Raney Nickel. This two-step procedure is then equivalent to a Friedel-Craft alkylation.

B/ Polonovsky rearrangement

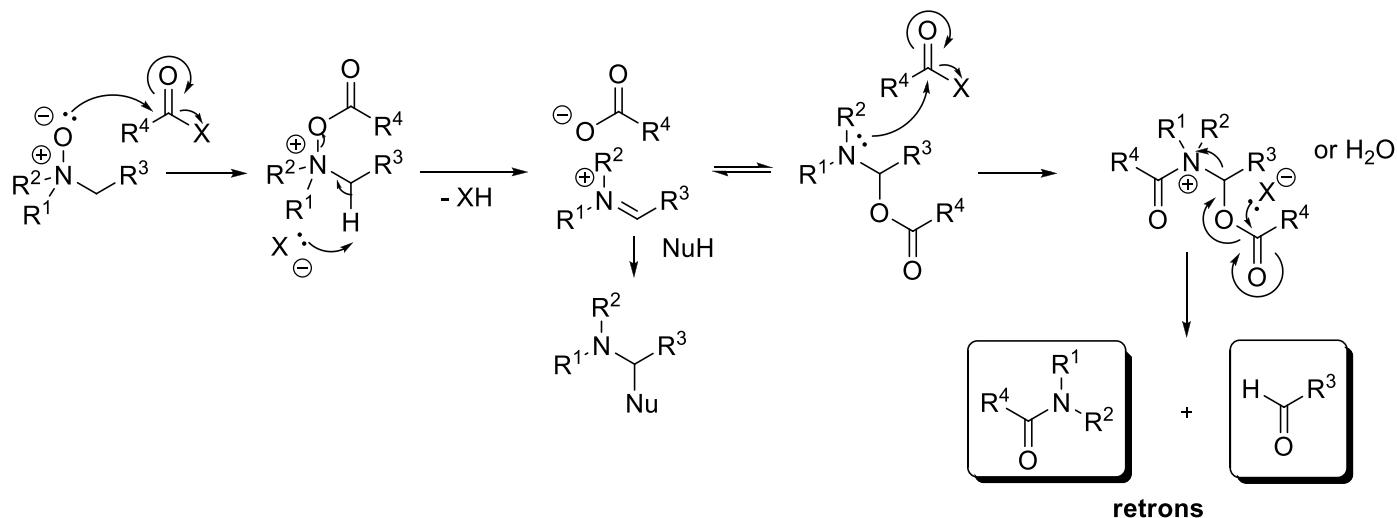

The Polonovsky rearrangement is the nitrogen equivalent of the Pummerer rearrangement. The reactions are similar, but the fact that nitrogen is a first row element leads to a few important differences: After activation with an acylation agent, the ammonium ylide is not formed from the acyloxylammonium, as it is less stable than the sulfonium ylide. A direct E₂ elimination takes place to form the iminium, that can be intercepted by the nucleophile. The higher nucleophilicity of the formed amine in comparison to sulfide allows further activation with the acylation agent, which leads to a very reactive acyloxy ammonium, which can already fragment to the amide and the aldehyde without addition of water. Synthetically, both fragments formed are now potentially interesting: the amide and the aldehyde.

3.2.2 Rearrangement involving carbenes or nitrenes-like intermediates

Properties of carbenes and nitrenes

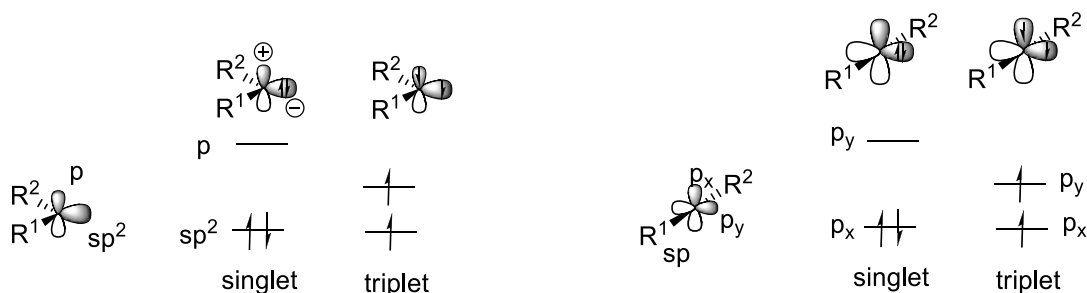

Carbenes are neutral compounds with a carbon atom with only 2 substituents and one lone pair. There are consequently only 6 electrons (sextet) around the carbon atom and the octet rule is not fulfilled. Both the electronic and the tridimensional structure of carbene is difficult to analyze, as they can have both a singlet (paired electrons) or triplet (unpaired, same spin electrons) and can be both sp^2 or sp hybridized. Generally, sp^2 carbenes are more frequent, as it allows to give more s character to the electrons, which are then better stabilized by the charge of the nucleus. The energy difference between triplet and singlet is usually quite small. If the difference is smaller than the electron-pairing energy, the triplet state will be preferred.

A/ CH_2

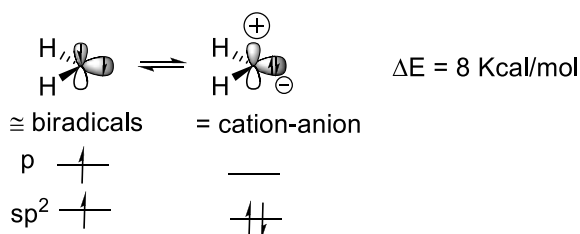

For the prototypical carbene CH_2 , the triplet state was found to be 8 Kcal/mol more stable than the ground state. In principle, radical-type chemistry is expected from the triplet state. Nevertheless, 8 Kcal/mol is not a use energy barrier, and if the singlet state is much more reactive, the reaction can take place through it. In this case, the carbene is usually electrophilic, because of the relatively low energy empty p-orbital. The reactivity is then "cation-like" (1,2-shift, addition to olefins). However, once a nucleophile has been added, the lone pair is now highly nucleophilic and reacts as nucleophile. Consequently, in most reactions involving carbenes, the sextet carbon will react both as electrophile and nucleophile, either stepwise or more or less synchronous.

B/Perturbation of CH_2

CH_3CH

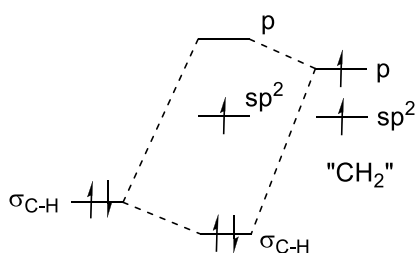
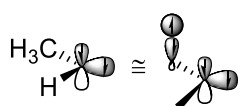

Replacement of one H group of CH_2 by a methyl group allows a hyperconjugation of the sigma C-H bond to the p orbital. Consequently, the p orbital is higher, and the difference in energy between the sp^2 and the p orbital greater. There is less difference in energy between triplet and singlet and more singlet reactivity can be observed.

CF_2

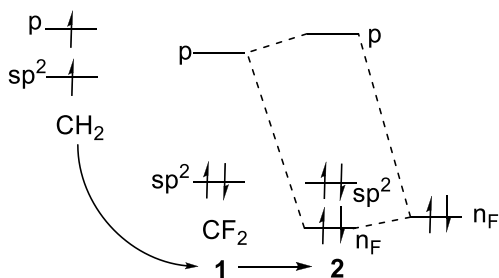
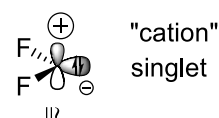

In CF_2 , the singlet structure is favored. A first important effect is the strong inductive effect of F, which makes the carbon center much more electronegative and consequently lowers a lot the energy of the sp^2 orbital (1). A second smaller effect is a partial delocalization of the lone pairs of F in the p orbitals (2). This second effect is naturally much stronger for CCl_2 .

C(NR₂)₂

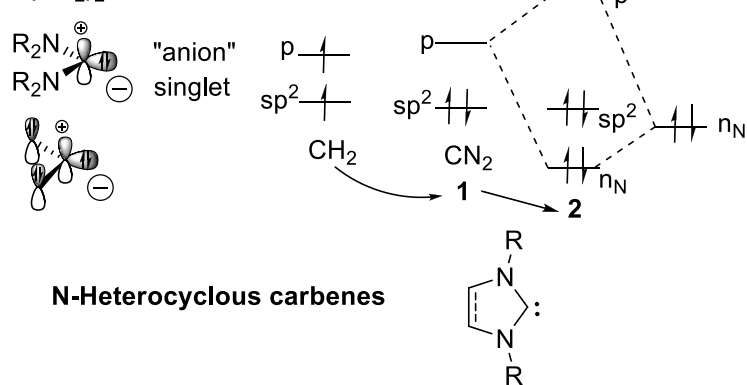

In principle, the structure and the reactivity of the C(NR₂)₂ system can be explained by the same two perturbation steps than for CF₂. However, in this case the importance of the two perturbations is inverted. N is only slightly more electronegative than C, and the sp² orbital is only slightly lowered. In contrast, the lone pair of N is nucleophilic, and two very strong interactions with the empty orbital can take place. The LUMO is now very high, the carbene is not electrophilic any more but nucleophilic. An important example is the N-heterocyclic carbenes, which have been used as catalysts or ligands.

Li₂C

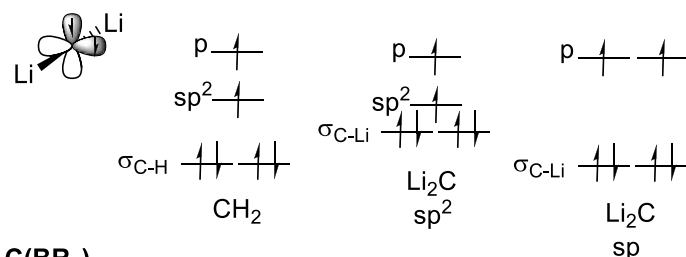

The case of the exotic Li₂C can be explained as following: The C-Li bond have a much higher electron density on C and are higher in energy. This high energy electrons are better stabilized in sp orbitals, with more probability at the nucleus. This overcompensates the energy lost in having the carbene electron in a p orbital. The structure now is a triplet, as both orbitals have the same energy.

C(BR₂)₂

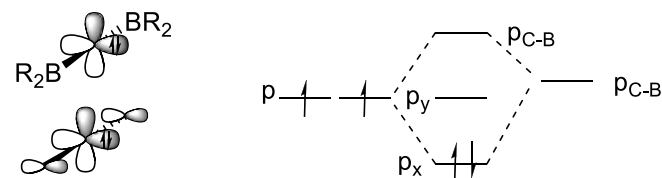

In the C(BR₂)₂ case, the change in geometry is necessary to allow stabilization of the carbene electrons by the empty p orbitals of B, as a pi symmetry is need for overlap. Only one of the two p orbitals can the be stabilized, and the energy gain is large enough to favor the singlet state.

A similar analysis can also be done for **nitrenes** (nitrogen with one substituent and 4 non bonding electrons). The principles stay the same, but the absolute value of the energy considered are different.

Carbenoids and nitrenoids

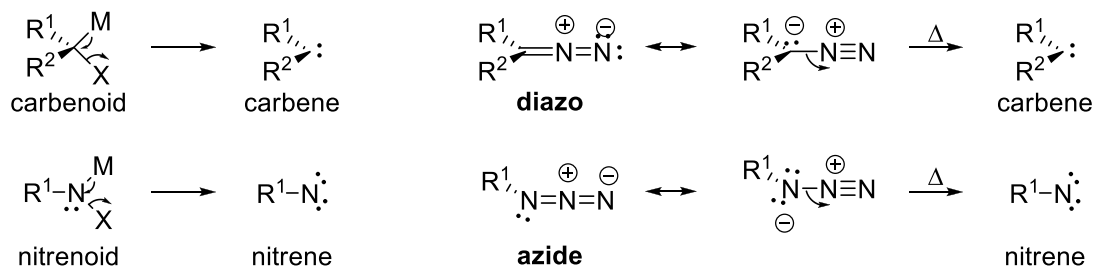

Metal-bond carbenes

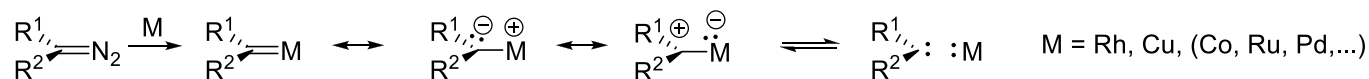

Carbenes and nitrenes are often generated from alpha elimination reactions or via release of nitrogen gas from diazo compounds or azides. Nevertheless, some precursors of carbenes and nitrenes are themselves very reactive, and sometimes react without the intermediacy of the free carben or nitrene. Such precursors are called carbene- or nitrenoids. Furthermore, metals are well-able to stabilized nitrenes and to change their reactivity. This aspect of carbene chemistry will be seen later in the lecture.

3.2.2.1 Rearrangements involving carbenes or carbenoids.

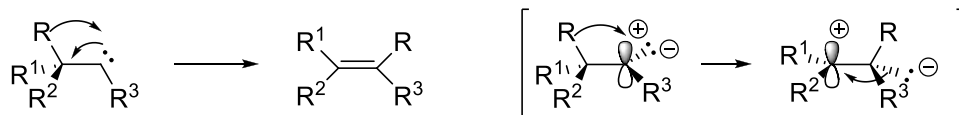

The [1,2]-shift of carbene intermediates is an easy reaction that shows their "cation-like" character. The lone-pair present on the carbene leads to the formation of a double bond, however. This process is mostly synchronous, but can also be described in two steps to show the importance of the cation-like character.

Synthetically important examples:

Wolff rearrangement

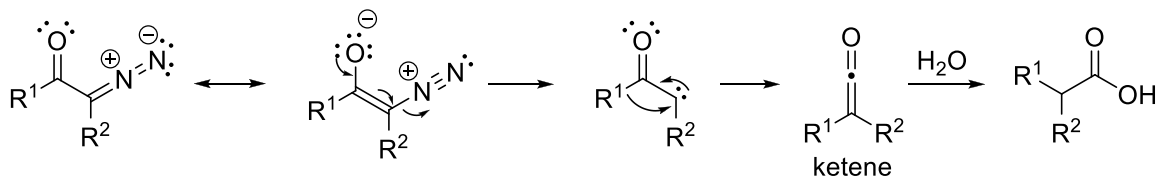

The Wolff rearrangement occurs on alpha-diazo carbonyl compounds. It begins with elimination of N_2 and formation of the carbene, followed by 1,2-shift to form a very electrophilic ketene. Quenching by water then gives the corresponding acid. It is also possible to react the ketene with alcohols or amines to obtain the corresponding esters and amides. A "carbenoid" like mechanism, with simultaneous shift and nitrogen lost can also be envisaged.

Arndt-Eistert homologation

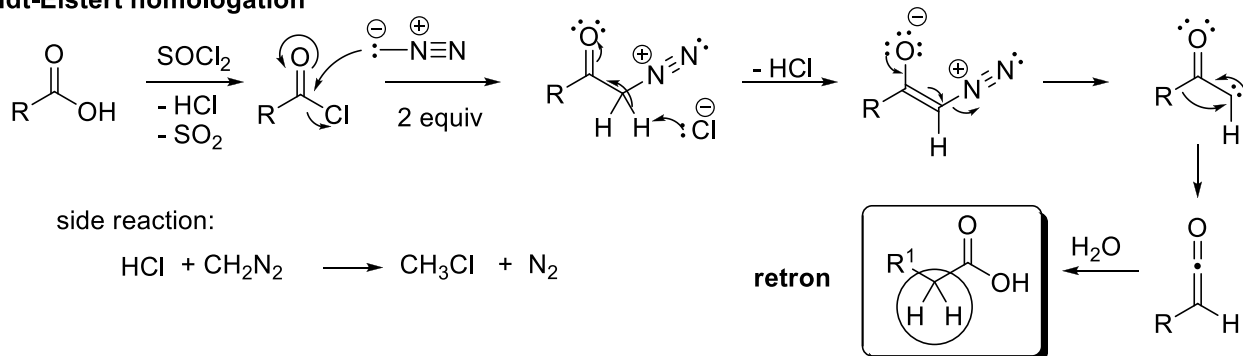

A particularly useful application of the Wolff rearrangement is the Arndt-Eistert homologation. A carboxylic acid is first activated with thionyl chloride. Reaction with diazomethane then gives the alpha-diazo carbonyl compound. Two equivalents of diazomethane are needed, as one equivalent is destroyed by the HCl formed in this step. Finally, Wolff rearrangement and reactions with water gives the corresponding acid. In the product, a CH_2 group has been introduced between the substituent and the carbonyl (homologation).

3.2.2.2 Rearrangements involving nitrenes or nitrenoids.

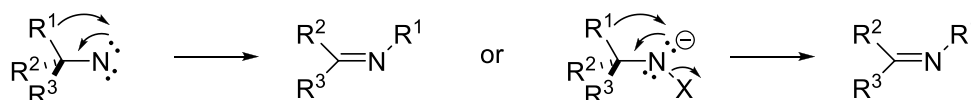

The amino equivalents of the carbene 1,2-shift are important reactions for the synthesis of imines. For most reactions under thermal conditions, a nitrenoid mechanism without formation of an isolated nitrene has usually been proposed. Nitrene intermediates are more probable under photolytic conditions.

Transformation of acid derivatives into amines

A/ Curtius rearrangement

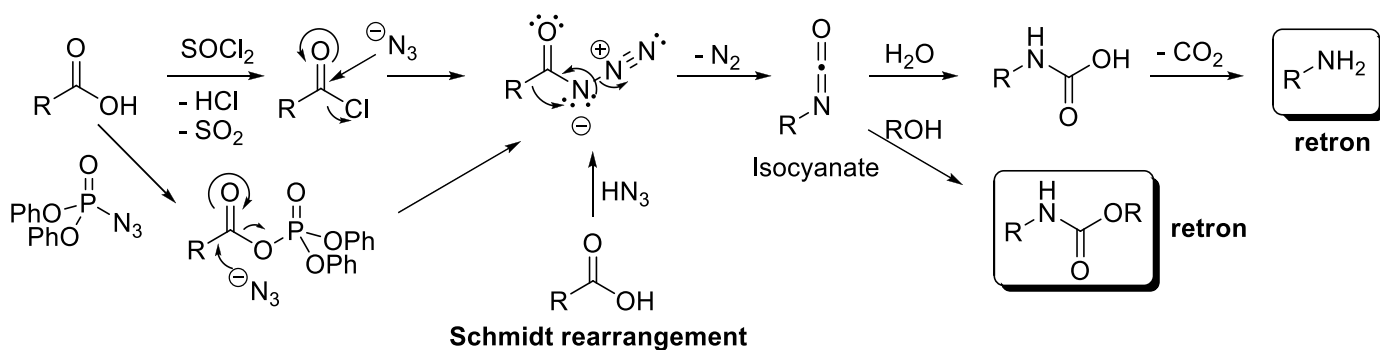

B/ Hofmann rearrangement

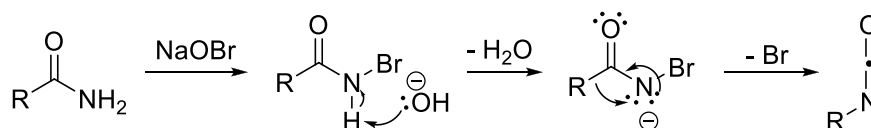

C/ Lossen rearrangement

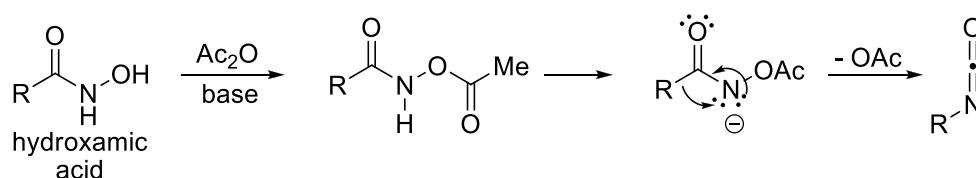

The transformation of acid derivatives into amines is an important reaction in organic chemistry, which proceeds via 1,2-shift. Several variations have been developed. The most often used is the **Curtius** variation starting from acid: activation as the acyl chloride followed by reaction with sodium azide gives the corresponding acyl azide. Upon heating, 1,2-shift with nitrogen release gives the corresponding isocyanate. Addition of alcohol leads to stable carbamates. The product resulting from the addition of water is unstable, however, and gives the free amine upon release of CO_2 . An interesting commercially available reagent for the one step conversion of acids into acyl azides is diphenoxyphosphonyl azide. Another possibility is the direct treatment of acids with hydrazoic acid (**Schmidt** method), but hydrazoic acid is highly toxic and explosive. The **Hofmann** method starts with the bromination of amides. After deprotonation, 1,2-shift occurs together with release of bromide. Finally, in the **Lossen** rearrangement a hydroxamic acid is activated by acylation. After deprotonation, 1,2-shift with loss of acetate gives the isocyanate.

3.2.3 Other intermediates

A/ Rearrangement via homolytic cleavage: Stevens rearrangement

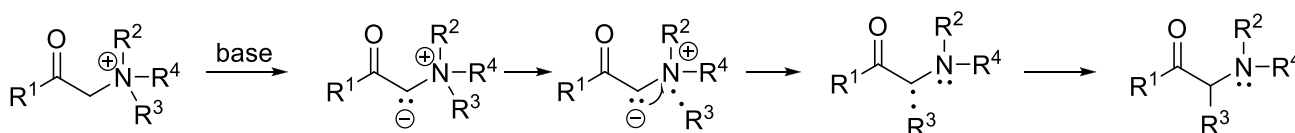

In the Stevens rearrangement, a 1,2-shift also takes place, but not towards a carbene or a cation and classical concerted shift is not possible. The shift of an alkyl group from an ammonium to a stabilized carbanion has been proposed to proceed heterolytically via radical pairs. The rearrangement is still partially concerted and no free radical are formed. The Stevens rearrangement is also possible on sulfonium salts.

B/ Favorskii rearrangement

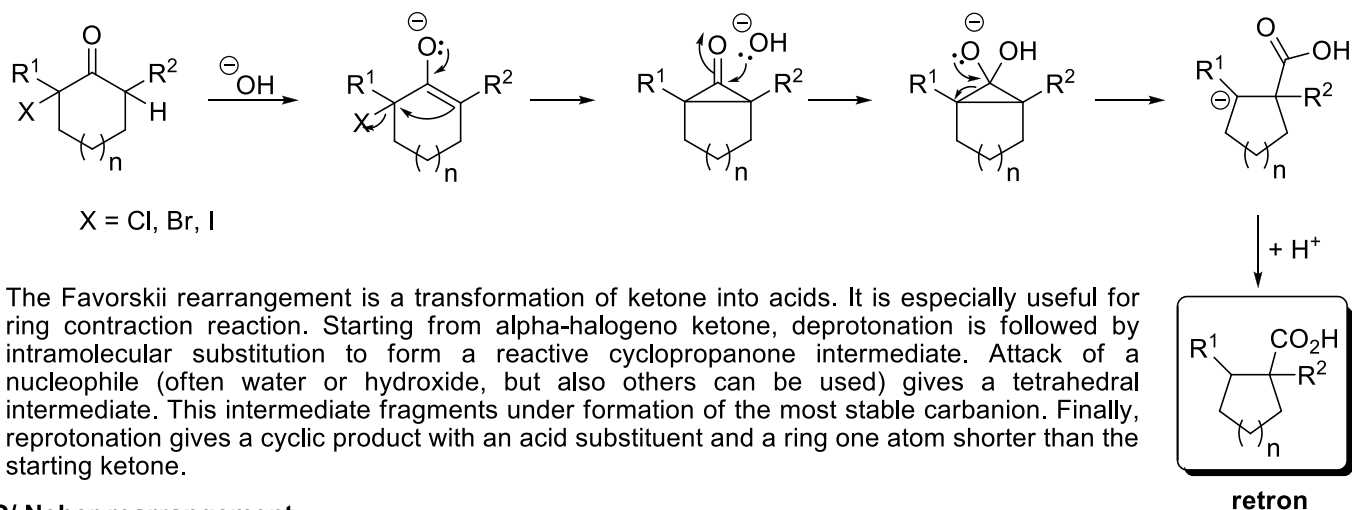

C/ Neber rearrangement

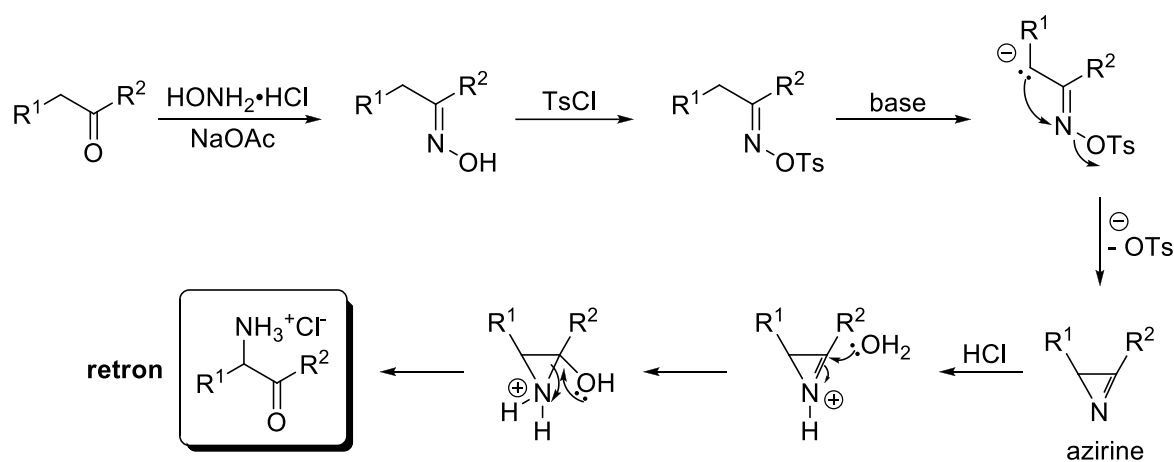

The Neber rearrangement is a useful method for the alpha-amination of ketones. The first steps are the same as for the Beckmann rearrangement: Oxime formation and activation. But in the next step, basic conditions lead to alpha deprotonation and intramolecular substitution to form a reactive azirine ring. The azirine ring is then hydrolyzed in presence of acid to give the hydrochloride salt of the alpha-amino ketone. The free amino ketone itself is not very stable, due to self-condensation.

4. Cyclization and Cycloaddition Reactions

Cyclic structures in organic molecules are essential for their properties, such as bioactivity. The goal of this chapter is to learn more in details the important methods to access cyclic structures in organic chemistry.

4.1 Cyclization reactions using classical methods

Bibliography: Evans, Lecture 3.

4.1.1 Baldwin rules (Baldwin, J. E. *J. Chem. Soc., Chem. Commun.* **1976**, 734.)

In principle, any classical reaction that has been used intermolecularly can be used intramolecularly to make a ring. The fact that the reaction is now intramolecular has important consequences:

- 1) **Entropy:** In intramolecular reactions, there is no loss of translational entropy. The reaction is consequently faster and easier and several processes which are inefficient intermolecularly function well intramolecularly. Furthermore, the entropic factor is less important when heating. Small rings have less entropy loss upon cyclization.
- 2) **Chemical compatibility:** It is important to realize that both reacting groups are present for intramolecular reactions. If it is required to activate one of the two groups, the activation conditions have to be tolerant to the other group.
- 3) **Cyclic constraints:** The fact that the molecule is now cyclic limits the number of structures that can be accessed. A classical example are cyclic olefins: *trans*-olefins become possible only if the ring contains at least 8 atoms (Bredt rule). Furthermore, for some ring sizes (especially 8-11) important steric interactions are present in the ring (transannular interactions). These rings are then particularly difficult to form.
- 4) **Cyclic constraints on the transition state:** stereocontrol is very important for organic reactions, which proceed via geometrically well defined transition states. However, some trajectories are difficult to achieve in intramolecular reactions, where the two reacting group cannot be freely oriented in the room. This effect has been studied in detail by Baldwin.

Baldwin nomenclature: For a systematic description of intramolecular reactions, Baldwin had introduced the following nomenclature:

- hybridization at the electrophile: **tet** = tetragonal (sp^3), **trig** = trigonal (sp^2), **dig** = digonal (sp)
- position of the electrons after the reaction: **exo**: outside the ring, **endo**: inside the ring.

The rules

Substitution (tet = tetragonal)

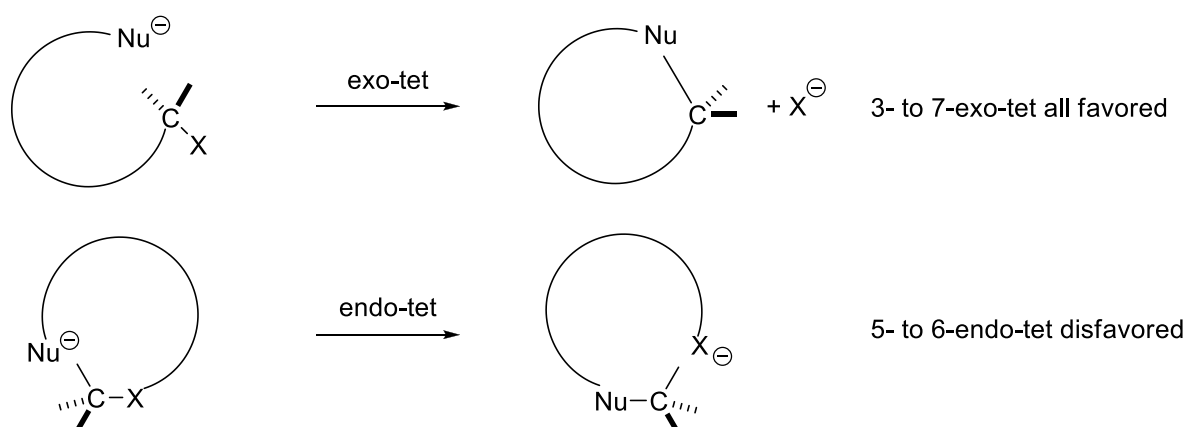

Required trajectory: 180° to X.

Typical reactions: Sn^2 substitutions, etherifications, opening of epoxides

Addition (trig = trigonal)

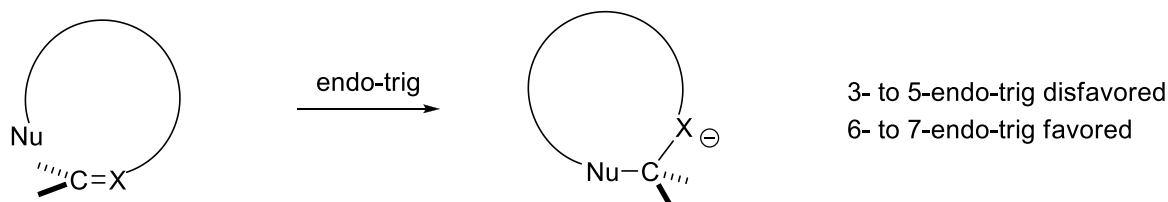
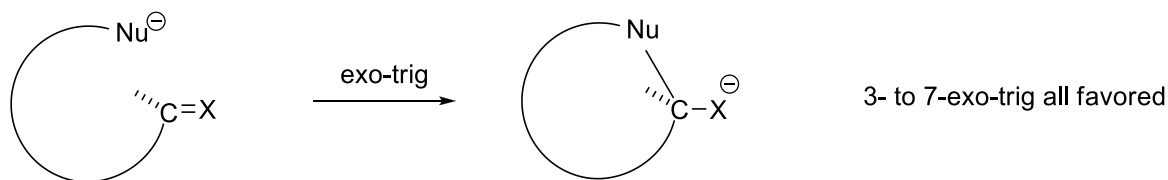

Required trajectory: 109° to pi-system (Bürgi-Dunitz trajectory).

Typical reactions: lactonizations, lactamizations, additions to carbonyls, aldols, additions to olefins

Addition (dig = digonal)

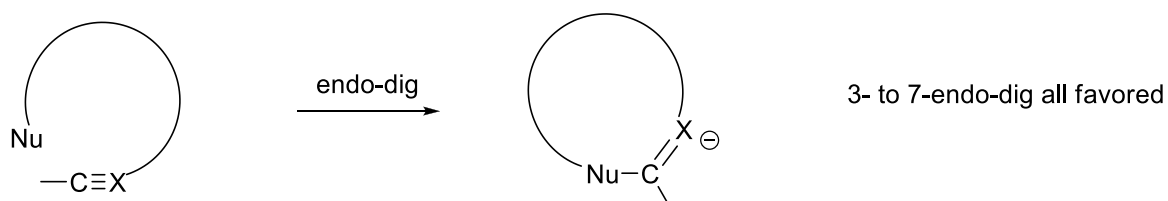
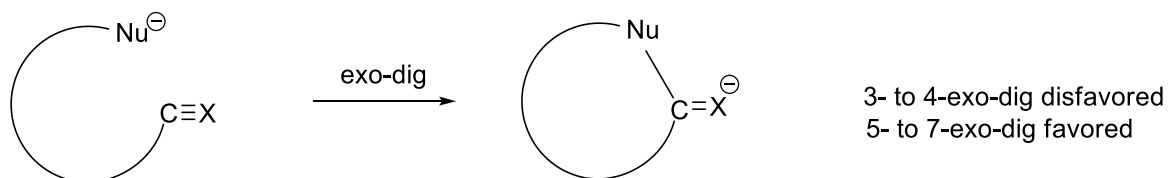

Required trajectory: 60° to pi-system

In contrast to the tet and the trig case, this angle is much more difficult to explain theoretically and was determined experimentally by Baldwin. The availability of a second pi bond and the possibility to distort the acetylene have been proposed as explanations.

Typical reactions: addition reactions to acetylenes and nitriles

Simplified and universal version of the rules

Easy cyclization ⇔ optimal orbital alignment possible

4.1.3. (Macro)lactonization

Bibliography: *Chem. Rev.* **2006**, *106*, 911.

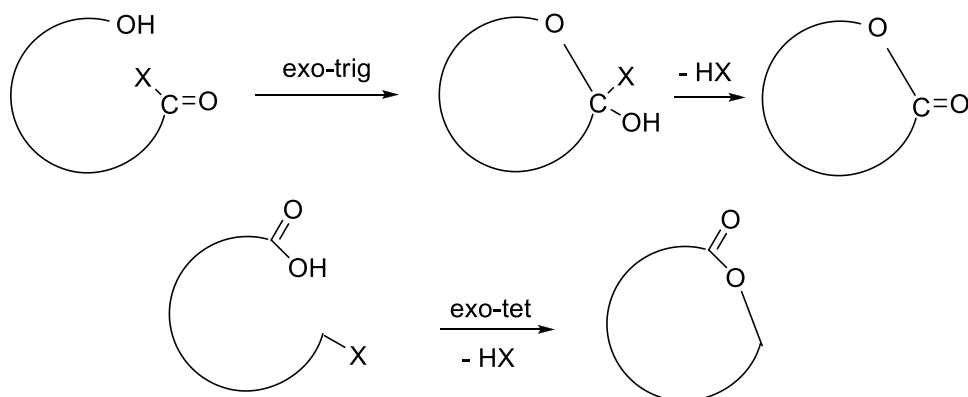

Dependence of rate on ring size

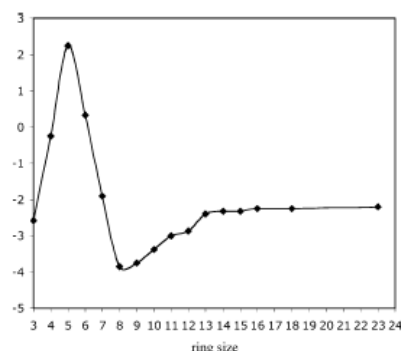

Lactones are very important rings in organic chemistry. In particular, large ring systems (macrolactones) are particularly difficult to synthesize, due to unfavorable steric interactions. The most often used methods are exo-trig attack of alcohols on activated carbonyl compounds (classical esterification being the simplest method) and exo-tet substitution of activated leaving group with carboxylic acids. In both processes, a proton is generated and a base is usually used to quench the formed acid. Generally, the desired cyclization reactions is favored under highly diluted conditions. It is furthermore important to "preorganize" the cyclization substrate by the introduction of rigidifying functional groups

Examples of bioactive (macro)lactones

Fongicides

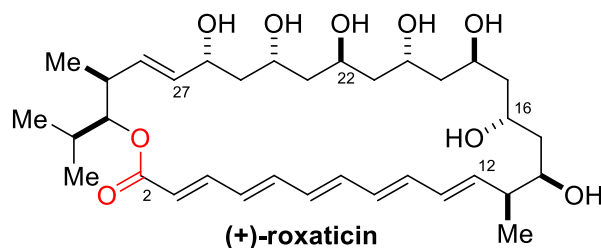
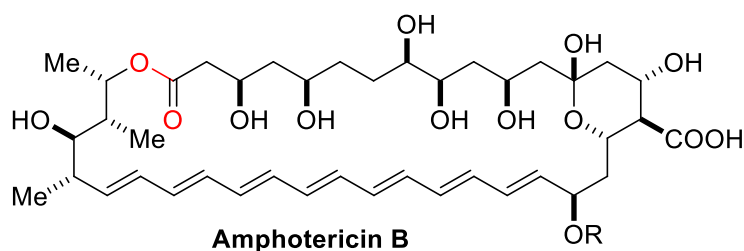

Anticancers

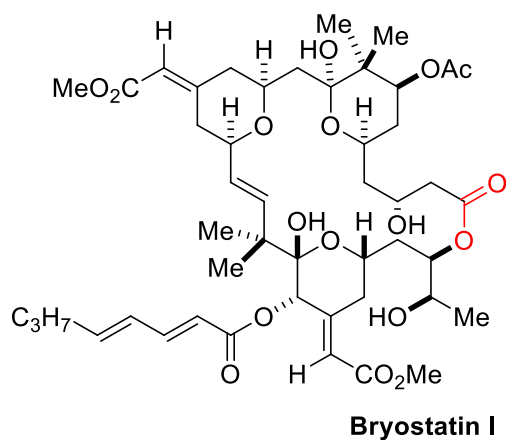
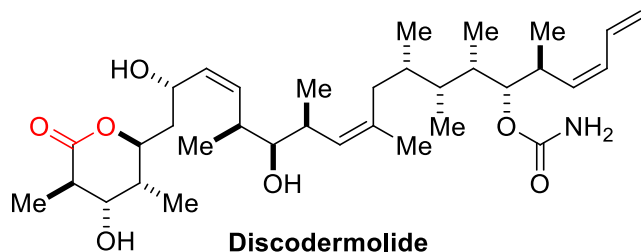

Antibiotics

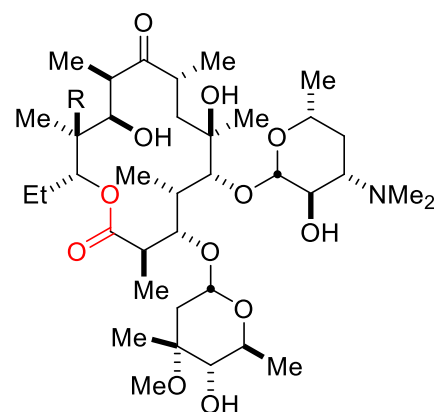

Synthetically important methods

A/ Iodolactonization

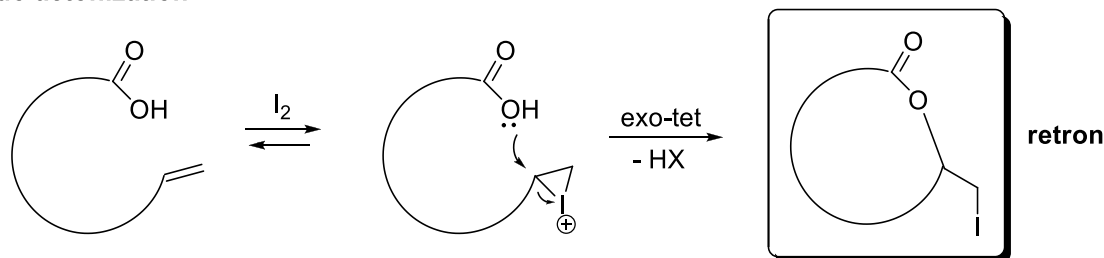

The iodolactonization is a very efficient method for the synthesis of lactones starting from carboxylic acids containing an alkene. In the first step, a iodonium intermediate is formed. An intramolecular exo-tet attack of the acid then gives the lactone and an iodide group that can be reduced or used for further functionalization. Without base, the carboxylic acid is not very nucleophilic and the attack is slow. Equilibration is possible (thermodynamic control). With a base, the first step is deprotonation of the acid to form a more reactive carboxylate. In this case, the attack can be fast enough so that the kinetic product is obtained.

B/ Mitsunobu reaction

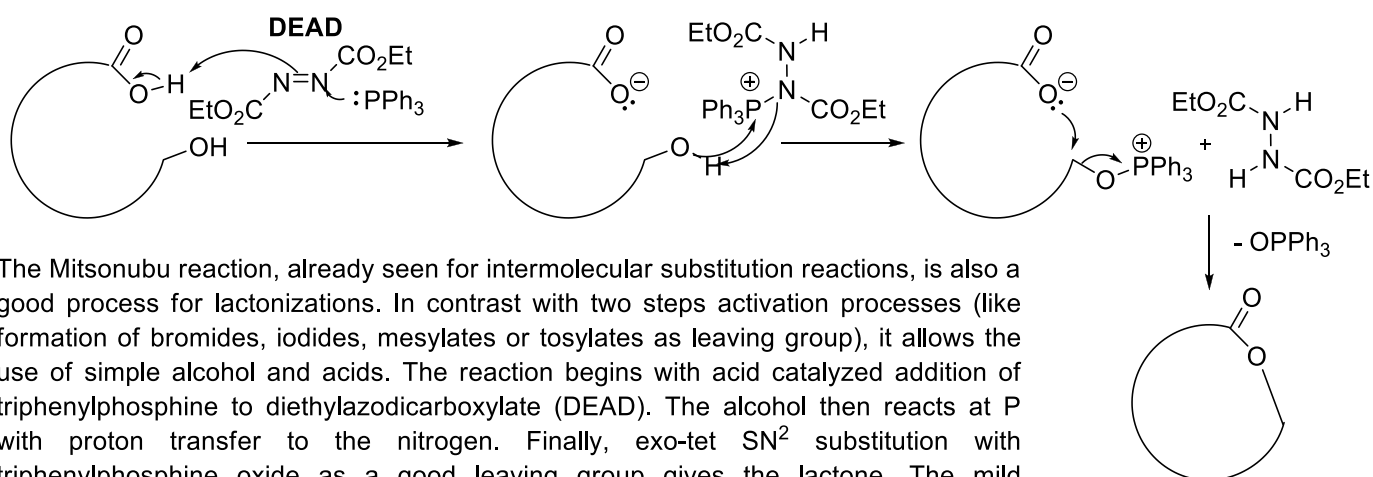

The Mitsunobu reaction, already seen for intermolecular substitution reactions, is also a good process for lactonizations. In contrast with two steps activation processes (like formation of bromides, iodides, mesylates or tosylates as leaving group), it allows the use of simple alcohol and acids. The reaction begins with acid catalyzed addition of triphenylphosphine to diethylazodicarboxylate (DEAD). The alcohol then reacts at P with proton transfer to the nitrogen. Finally, exo-tet SN_2 substitution with triphenylphosphine oxide as a good leaving group gives the lactone. The mild conditions are an advantage of the Mitsunobu reaction. A disadvantage are the large amounts of waste (hydrazine, phosphine oxide) generated.

C/ Thioesters: Corey-Nicolaou method

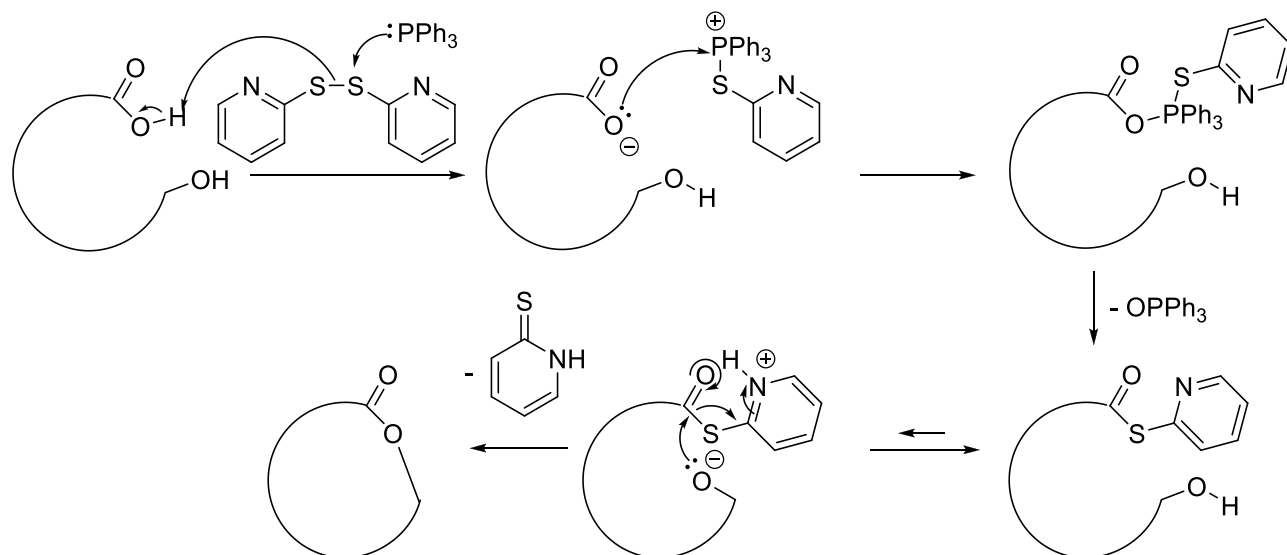

The Corey-Nicolaou method makes use of the higher reactivity of thioesters when compared with esters. In the first step, a thioester is formed from the acid with formation of triphenylphosphine oxide. The thiopyridone ester formed is basic enough to partially deprotonate the alcohol, which makes the thioester even more electrophilic. After exo-trig attack and release of the thiopyridone, the desired lactone is formed.

D/ Yamaguchi Lactonization

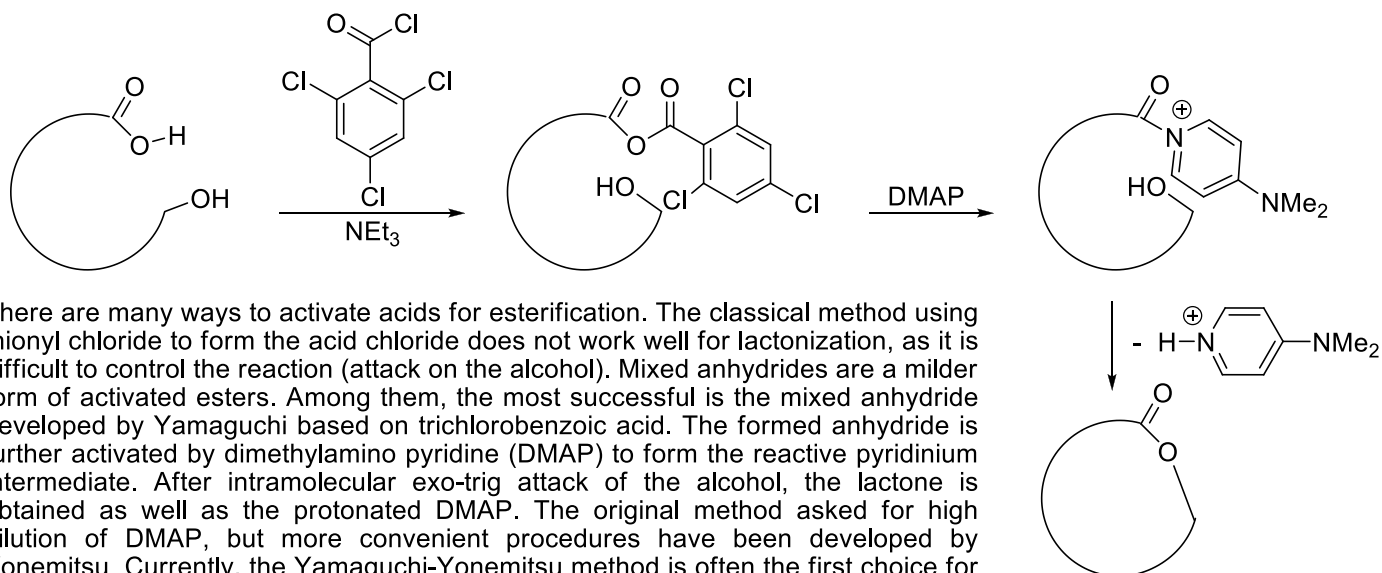

There are many ways to activate acids for esterification. The classical method using thionyl chloride to form the acid chloride does not work well for lactonization, as it is difficult to control the reaction (attack on the alcohol). Mixed anhydrides are a milder form of activated esters. Among them, the most successful is the mixed anhydride developed by Yamaguchi based on trichlorobenzoic acid. The formed anhydride is further activated by dimethylamino pyridine (DMAP) to form the reactive pyridinium intermediate. After intramolecular exo-trig attack of the alcohol, the lactone is obtained as well as the protonated DMAP. The original method asked for high dilution of DMAP, but more convenient procedures have been developed by Yonemitsu. Currently, the Yamaguchi-Yonemitsu method is often the first choice for macrolactonization reactions.

Due to the importance of the macrolactonization reaction, there are many more methods, which are not described here (see *Chem. Rev.* **2006**, 911.), many based on ester activation. The mechanism principles stay the same, however. Furthermore, methods for lactamization have also been developed: these methods are very close to the one used in peptide chemistry.

4.2 Electrocyclic Reactions

Bibliography: Carey-Sundberg, A, Ch. 10.5, p. 892-911. Evans, lectures 11-12.

4.2.1 Woodward-Hofmann rules

We have already seen the Woodward-Hofmann rules in the case of H-Shift over pi systems. In fact, the Hofmann rules were first described for electrocyclic ring-closing and opening reactions.

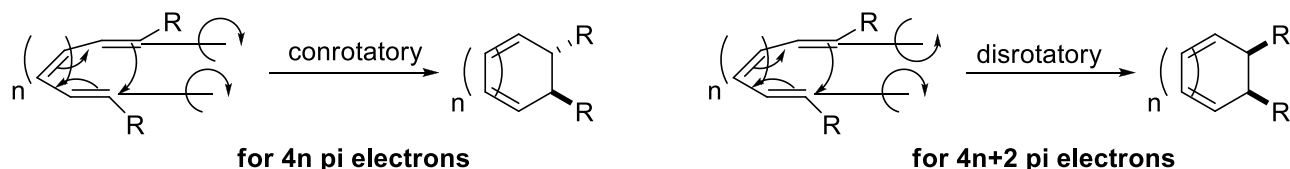

From the point of view of electron shifting, electrocyclic ring closure looks simple: a cyclic rearrangement of electrons leads to ring closure. What cannot be explained with simple Lewis structures is the high diastereoselectivity of the processes. Systems containing $4n$ pi electrons (2, 4, ... double bonds) reacts conrotatory to form the *trans* product starting from the *trans* olefin, and systems with $4n+2$ pi electrons (1, 3, 5, ... double bonds) react disrotatory to form the *cis* product from the *trans* olefin. These results can be explained when considering the symmetry of the HOMO of the pi systems. This leads to the more general (and easier to remember) Woodward-Hofmann rule:

Simplified version of the Woodward-Hofmann rules:

Reaction is allowed if there is a correct phase overlap/ symmetry of the orbitals

4.2.2 Electrocyclic ring-closure

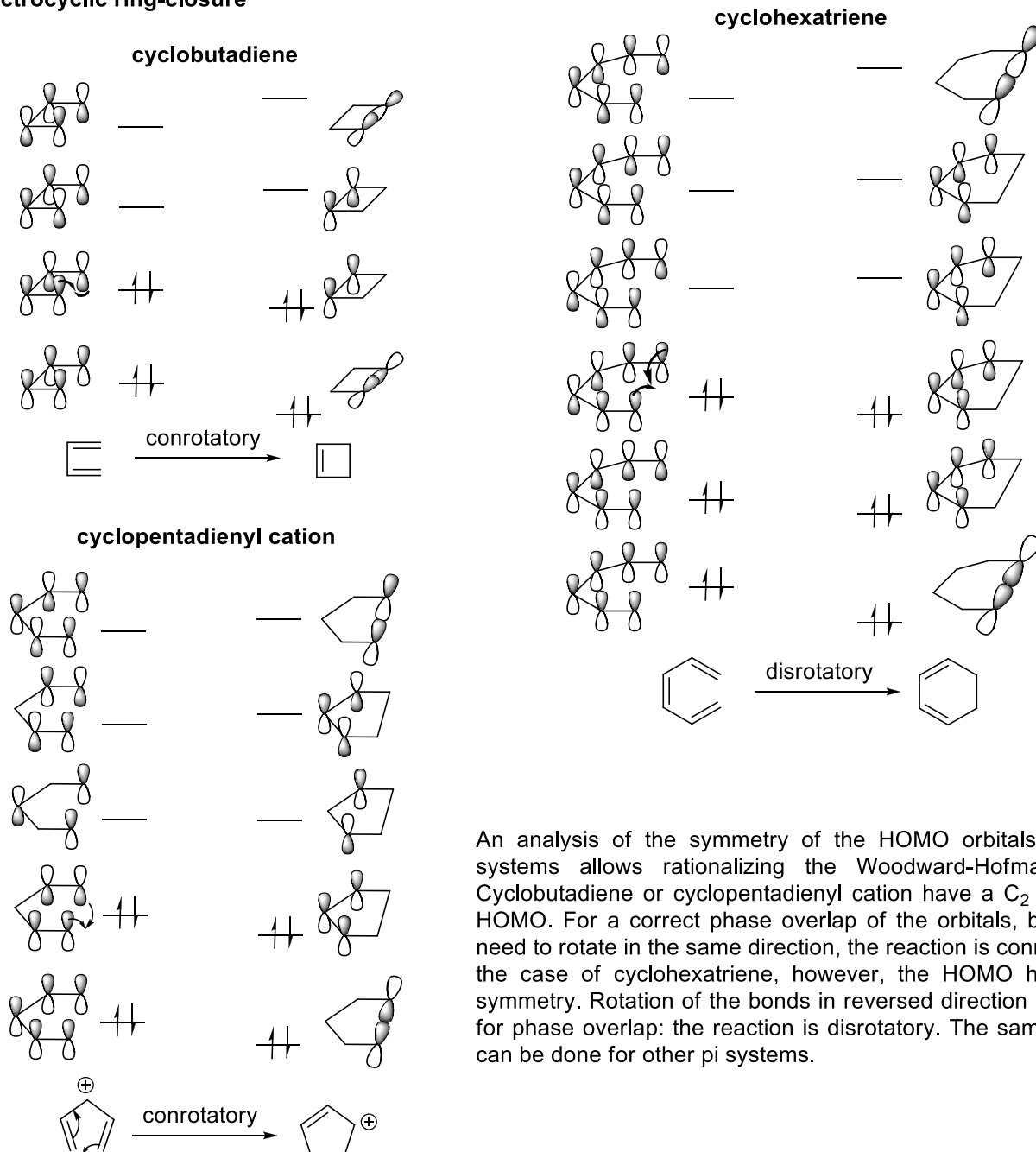

Nazarov Cyclization

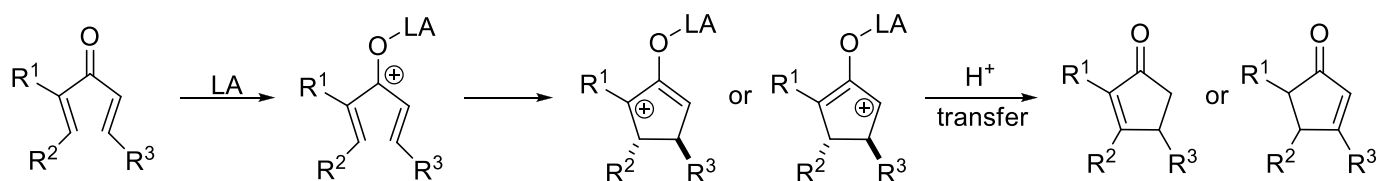

The Nazarov cyclization is the conversion of divinylketones to cyclopentenones. It is an important method for the synthesis of 5-membered ring. After activation with a Lewis or Brønsted acid, a cyclopentadienyl cation is formed, that cyclizes to the corresponding 5-membered allylic cation. The usual fate of the cation is E_1 elimination, although trapping with nucleophiles is also possible (interrupted Nazarov reaction). In principle, two regioisomers can be obtained, and the selectivity is dependent on the most stabilized carbocation. If R^1 is a cation stabilizing group, like oxygen or nitrogen, than high selectivity is observed.

4.3 (Alder) Ene Reactions

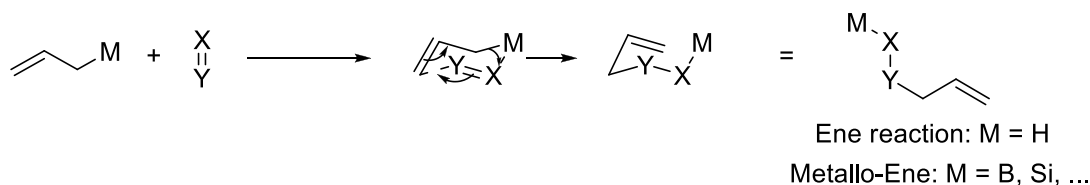

The ene reaction is the concerted reaction of an allylic system with a pi system. The original ene is with a H at the allylic position, but the reaction is very slow. In fact, so-called metallo-ene are much more useful (see chapter 2). For substituted systems, the usual analysis for chair transition states stay valid.

Synthetically useful reaction

Carbonyl ene

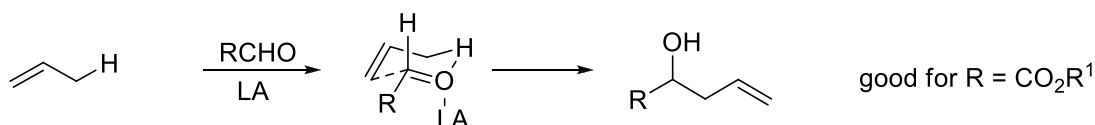

Carbonyl as pi systems are more reactive than olefins, so that the ene reaction becomes easier. But even in this case strong Lewis acids are required. The reactions runs best with activated aldehydes, such as glyoxal. An advantage of the ene reaction is that no pre-functionalization of the allylic system is required.

4.4 Cycloadditions

4.4.1 Diels-Alder Cycloadditions

Bibliography: Carey-Sundberg A, Ch. 10.2, p. 839-873; B, Ch. 6.1, p. 473-526. Carreira: Ch. 17. p. 551-589. Evans: lectures 16-17. Bruckner: Ch. 15.3, p. 654-671.

4.4.1.1 Mechanism



The Diels-Alder cycloaddition between a diene and an olefin (dienophile) is the most well-known cycloaddition reaction and it is intensively used in organic chemistry. Every chemist should be able to recognize the cyclohexene retron for the Diels-Alder reaction. The reaction is concerted via a 6-membered transition state. The diene needs to be in the *s-cis* conformation for the reaction, and substrates that are forced in this conformation will react faster. The Diels-Alder is a bimolecular reaction which becomes less favorable at high temperature. It is favored by high pressure (tight transition state) and high concentration. A special technique is to run the reaction in water: as most organic substrates are poorly soluble, they tend to aggregate in water, such that an artificial very high concentration is reached.

Transition state Analysis

A/ Diradicaloid

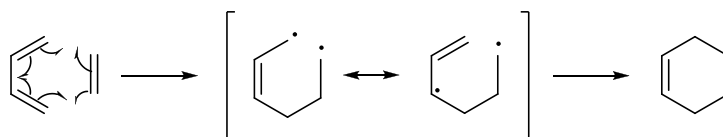

B/ Polarized intermediates

B1/ normal electron demand

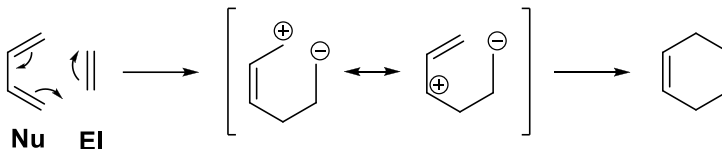

B2/ inverse electron demand

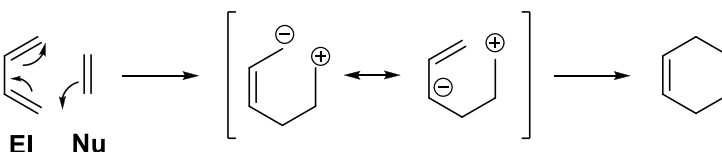

C/ Orbitals

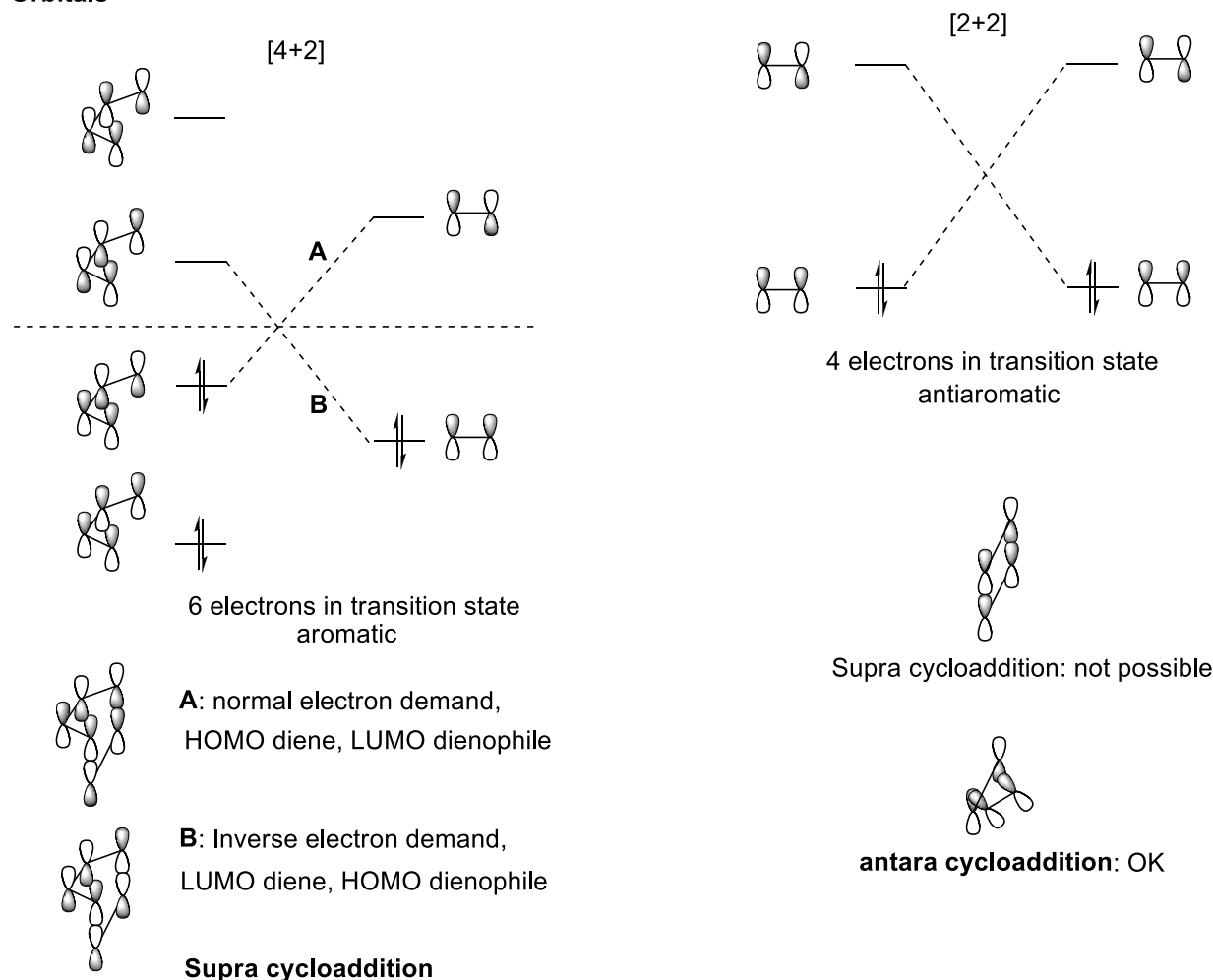

There are several models to describe the transition state of the Diels-Alder reaction:

A/ Biradicaloids

As for sigmatropic rearrangements, the use of biradicaloid intermediates to describe the transition state is a good method for the Diels-Alder reaction. The relative stability of the different intermediates allow to predict the selectivity and to have an idea about the rate of the reaction. A quantitative use of this model is seen in physical organic chemistry lectures.

B/ Polar Intermediates

The use of polar intermediates become important as soon as electron-donating or withdrawing substituents are introduced on the diene or dienophile. Two different cases can be distinguished: an electron-rich nucleophilic diene and an electron-poor electrophilic dienophile (normal electron demand) or an electron-poor electrophilic diene and an electron-rich nucleophilic dienophile (reverse electron demand). The normal electron-demand is synthetically most often used. The two cases will be seen in details later.

C/ Orbitals

Again, the orbital model is powerful to describe the Diels-Alder reaction. The most important interactions are the one of the frontier orbitals, and the geometrical overlap of the p orbitals determine the structure of the transition state. like for the polarized model, it is also possible to describe to limiting cases: normal electron demand with the HOMO of the diene and the LUMO of the dienophile or reverse electron demand with the LUMO of the diene and the HOMO of the dienophile. The orbital model allows also to understand why the supra (same face) [4+2] cycloaddition is easy (allowed): the phases/symmetry of the orbitals are correct for overlap (Woodward-Hofmann rules). In contrast, the [2+2] cycloaddition is not possible in the supra mode, but becomes possible as antara (crossed face) cycloaddition. Another way to understand these results is to look at the number of electrons in the transition state: 6 electrons for the [4+2] are aromatic, and 4 electrons in the [2+2] are antiaromatic (or Möbius aromatic).

4.3.1.2 Normal electron demand Diels-Alder reaction

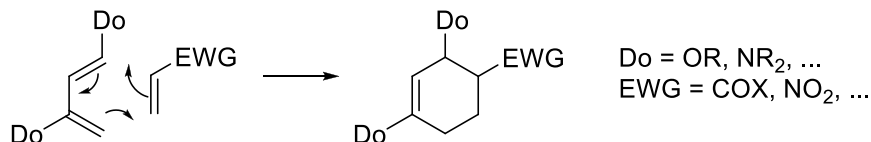

In the normal electron-demand Diels-Alder reaction, electron donating groups are introduced on the diene (in position 1 and/or 3) and an electron-withdrawing group on the dienophile. The dienophile can be further activated by the addition of a second electron-withdrawing group. The reaction is now much faster and regio-selective: both the rate enhancement and the selectivity can be explained using polarized or orbital models.

Analysis of the transition state

A/ Polarized model

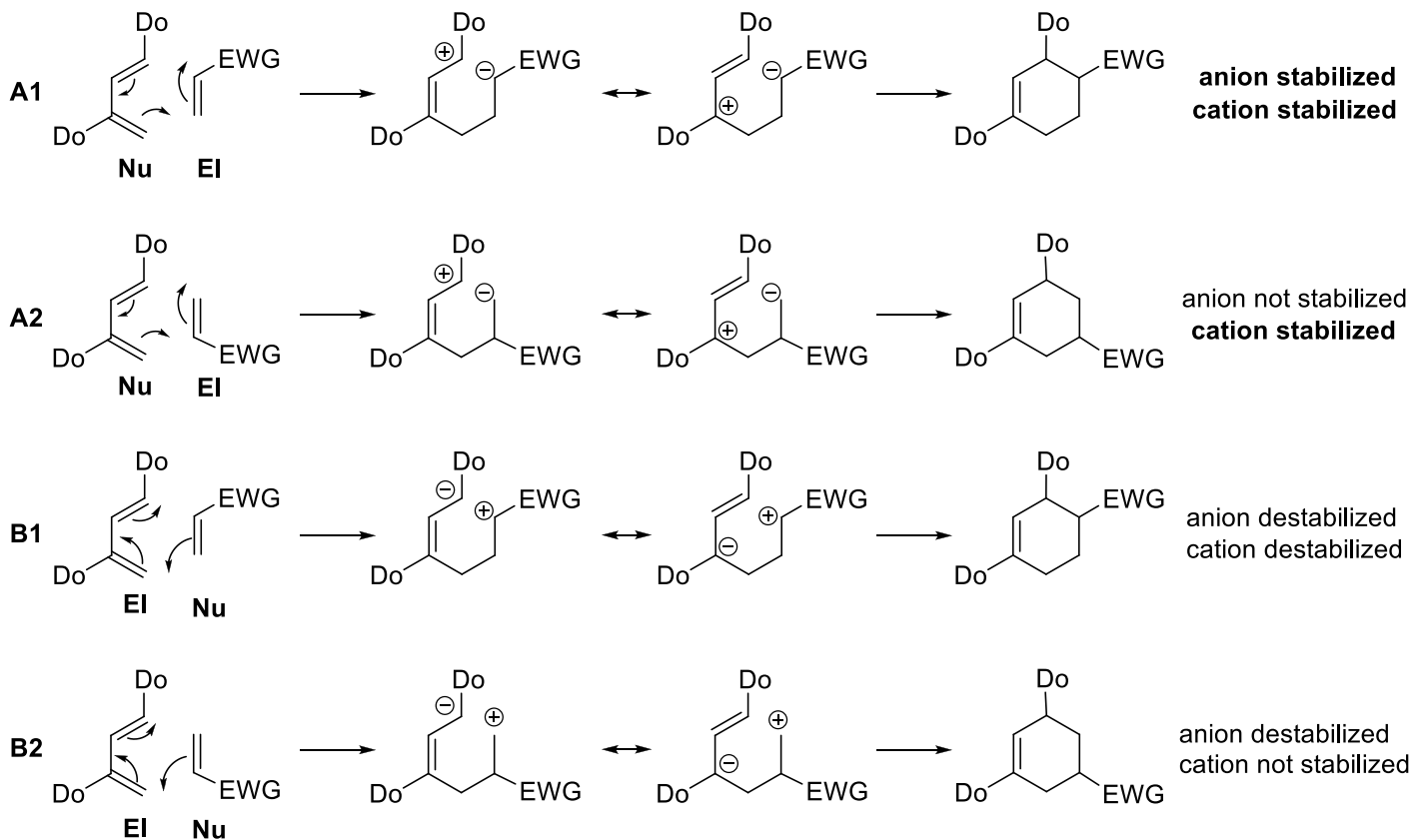

When the diene and the dienophile are substituted, 4 different pathways can be drawn using polarized intermediates for the Diels-Alder reaction. In two of them (B1 and B2, corresponding to an inverse electron demand reaction), destabilizing interactions between donor and anion and/or between acceptor and cation are introduced: these pathways will consequently be less important than in the unsubstituted case and will not contribute to the reaction. In the other pathways (A1 and A2), at least the carbocation is always stabilized, the transition state would be lower and the reaction accelerated when compared with the non-substituted case. Furthermore, only A1 has a stabilizing interaction between the acceptor and the anion: this pathway is most favorable and explains the ortho/para regioselectivity observed in Diels-Alder reactions. The stabilization of the cation also shows that 1,3 donor substitution is optimal for stabilization.

B/ Orbital Model

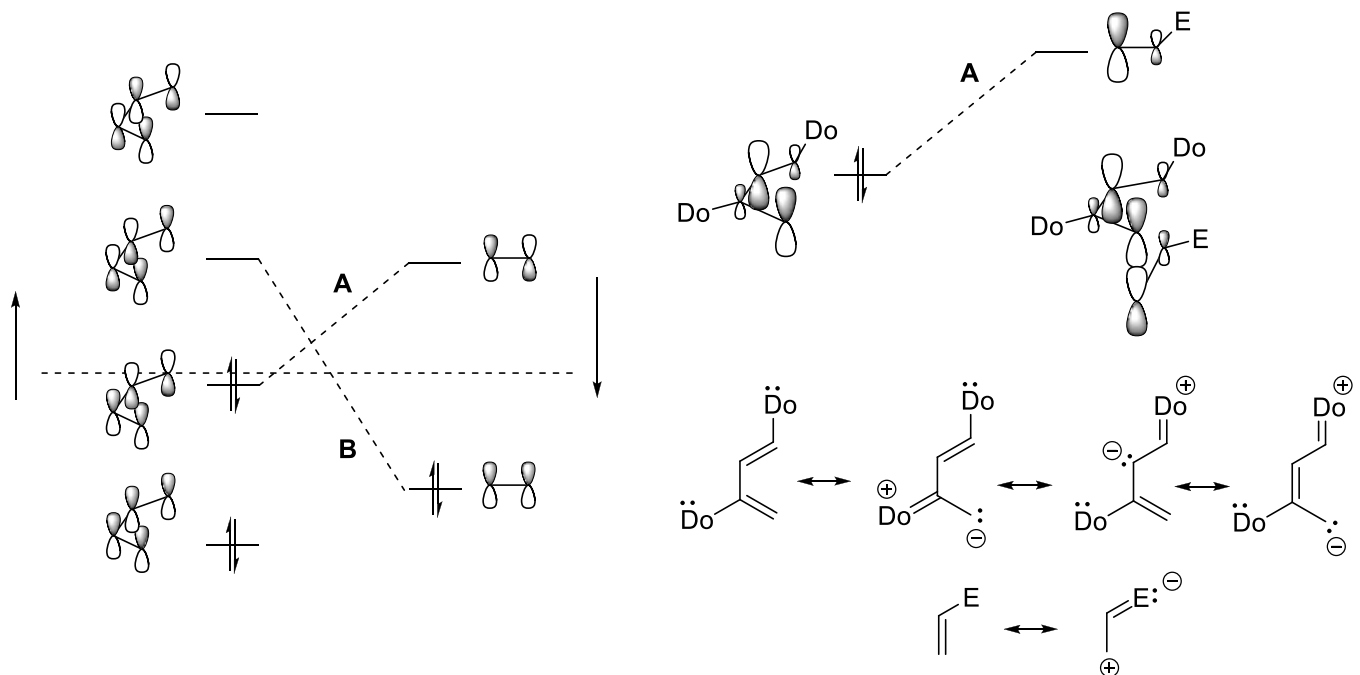

The introduction of the substituents on the diene and dienophile first changes the energy of the molecular orbitals. The electron-donating groups on the diene shift the energy up, the electron-withdrawing group on the dienophile shifts the energy down. As a result, only the interaction between the HOMO of the diene and the LUMO of the dienophile is important. As the energy difference between these two orbitals is smaller than for unsubstituted systems, the interaction is more favorable and the reaction faster. A second important result is the unequal coefficients of the orbital in the HOMO and the LUMO due to the presence of the substituents. The overlap between the orbitals with the larger coefficients is better and explain the regioselectivity. The orbital coefficients can be qualitatively estimated by using resonance structures: for the diene, a partial negative charge can be put only in position 2 and 4. These positions will have higher electron density and also larger coefficients in the HOMO. For the dienophile, a partial positive charge is present in position 2. The orbital of the LUMO will consequently be larger there. Of course, quantitative calculations give much more precise results and these methods will be seen in physical organic chemistry.

Catalysis

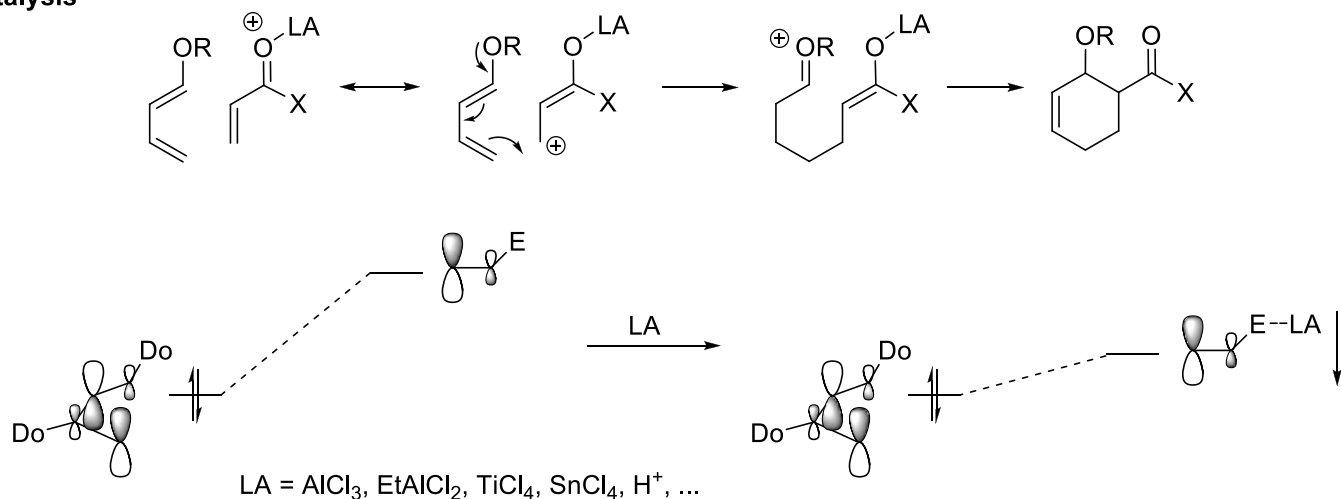

The discovery that Lewis acids can accelerate the normal electron-demand Diels-Alder reaction was an important progress in organic chemistry. The binding to a Lewis acid makes the dienophile much more electrophilic, the LUMO is lowered and the reaction is accelerated. In such cases, the Diels-Alder reaction can be run at room temperature or even lower temperatures.

endo rule

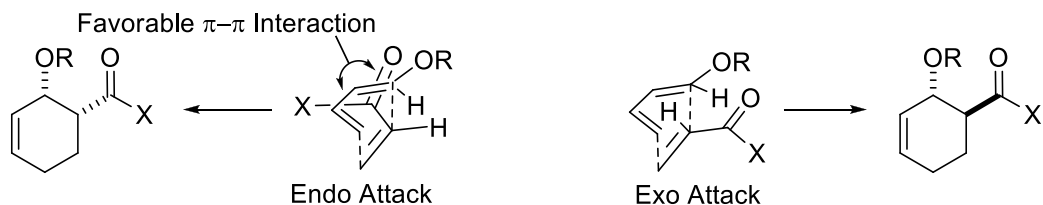

In many normal hetero Diels-Alder reactions, the *cis* product resulting from an endo attack is favored. This is due to the favorable interactions between the electron-rich pi system of the diene and the electron-poor substituent on the dienophile. In case of very large X group or bulky Lewis acids, the exo attack can become favorable.

synthetically useful dienes

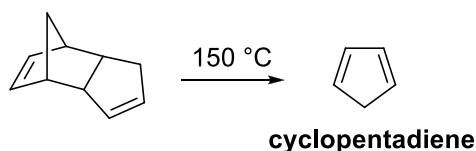

Cyclopentadiene is a very good diene for Diels-Alder reactions, as it is blocked in the *s-cis* conformation. In fact, it dimerizes spontaneously to form dicyclopentadiene and has to be cracked at high temperature before use.

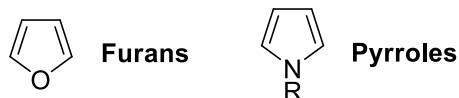

Furans and pyrroles can also be used in Diels-Alder reactions, but there are much less reactive than cyclopentadiene, due to their aromaticity.

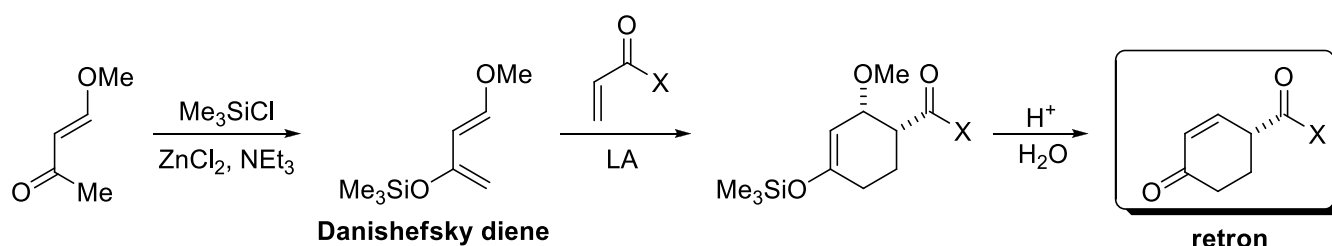

The **Danishefsky diene** is a particularly useful electron-rich diene for Diels-Alder reaction. It is easily prepared by formation of the silyl enol ether starting from the corresponding ketone. The two electron-donating oxygen groups gives high reactivity to this diene. Hydrolysis of the silyl enol ether and elimination of methanol finally gives a cyclohexenone as final product, that can be further functionalized.

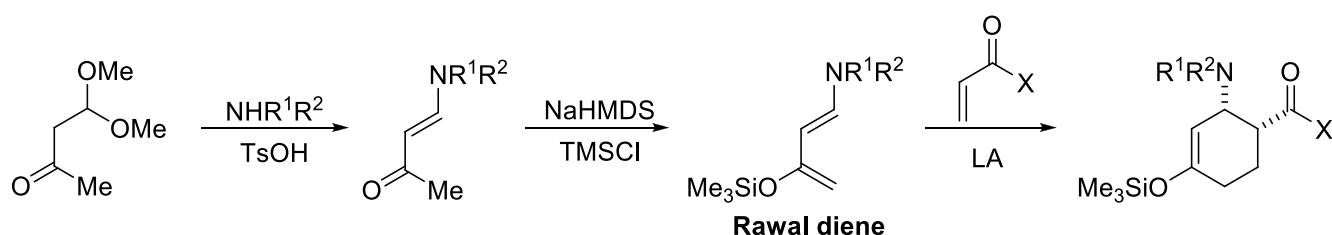

In the Rawal diene, one of the oxygen substituents has been substituted with a nitrogen. As nitrogen is more electron-rich, this diene is more reactive and very mild Lewis or Brønsted acids are enough to catalyze the reaction. It allows the introduction of nitrogen into organic molecule. The first step in the preparation of the diene is the acid-catalyzed reaction with an acetal, which proceeds via iminium and enamine intermediates. Formation of the sodium enolate followed by reaction with TMSCl then gives the diene.

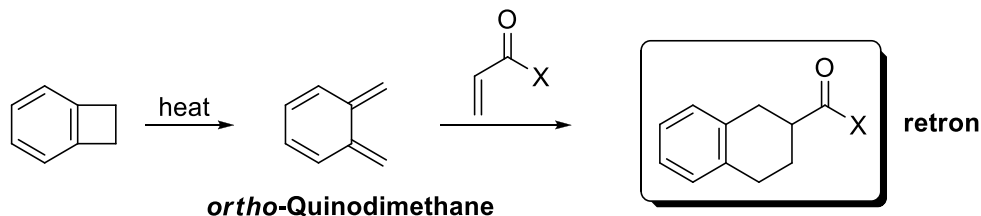

Ortho-quinodimethanes are very reactive dienes, due to the aromatization occurring during the Diels-Alder reaction. They are too reactive to be isolated and need to be generated in situ. A good method is the electrocyclic ring opening of benzenecyclobutanes.

Important dienophiles

dienophiles activated by carbonyl groups:

1 carbonyl group

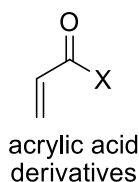
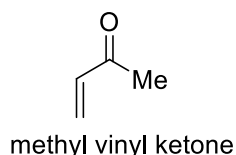
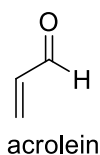

X = OR, NR₂,...

2 carbonyl groups

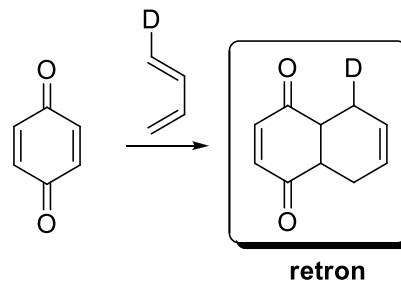
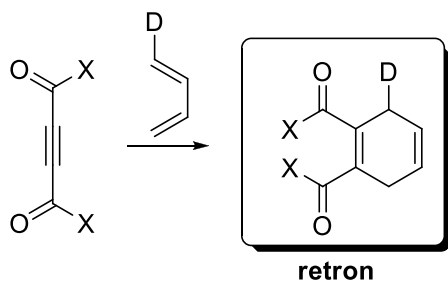
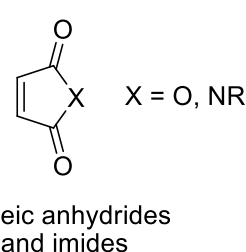
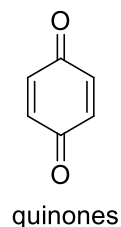
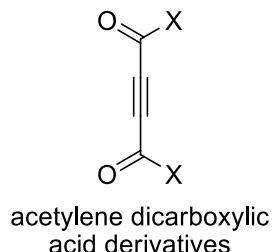
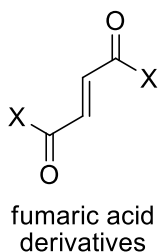
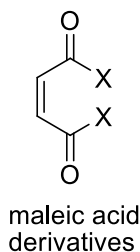

The dienophiles activated by carbonyl groups are by far the most often used in Diels-Alder reactions. The reactivity is dependent on the electrophilicity of the carbonyl group (aldehydes > ketones > esters > amides). A further increase in reactivity can be achieved by introducing a second carbonyl group. In particular, acetylenes react poorly in Diels-Alder reactions, and a second activating group is required. Quinones are very important dienophiles for the synthesis of polycyclic compounds.

chloroacrylonitrile

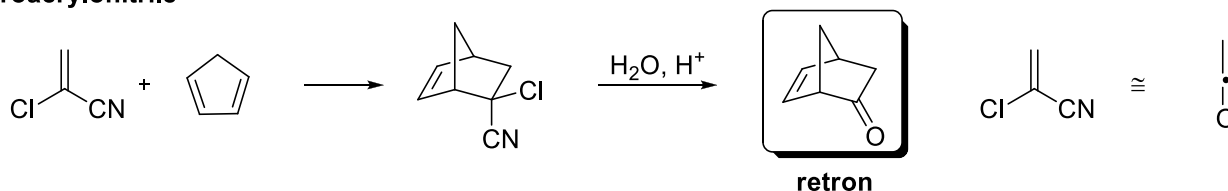

Alpha-chloroacrylonitrile is an interesting dienophile, as it can be used as ketene equivalent after hydrolysis, but is stable and easy to handle, in contrast to ketene itself.

nitroolefins

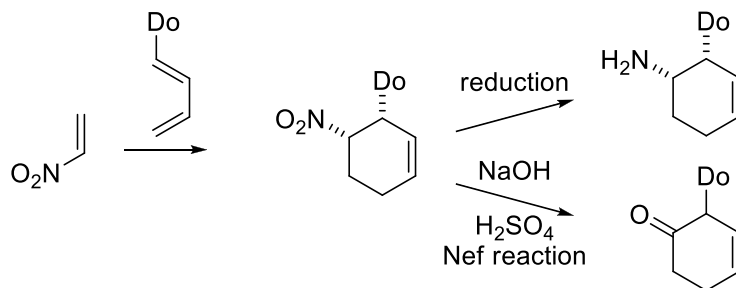

Nitroolefins are also good dienophiles in Diels-Alder reactions. The obtained products can be easily transformed to amines via reduction or to ketones via the Nef reaction (formation of the nitronate followed by hydrolysis under acidic conditions).

vinyl sulfones

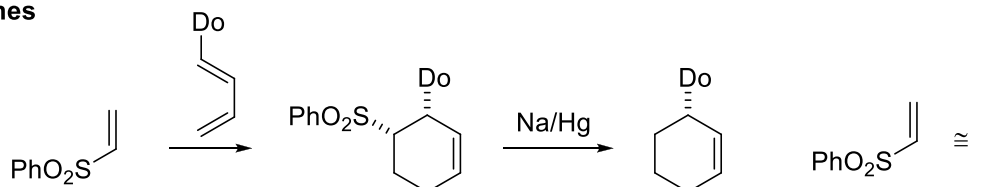

Sulfone substituted olefins are also very electron-deficient and good substrates for the Diels-Alder reaction. An advantage of the sulfone is that it can be removed under reducing conditions. Vinyl sulfone is then a synthetic equivalent of ethylene.

4.3.1.3 Inverse electron demand Diels-Alder reactions

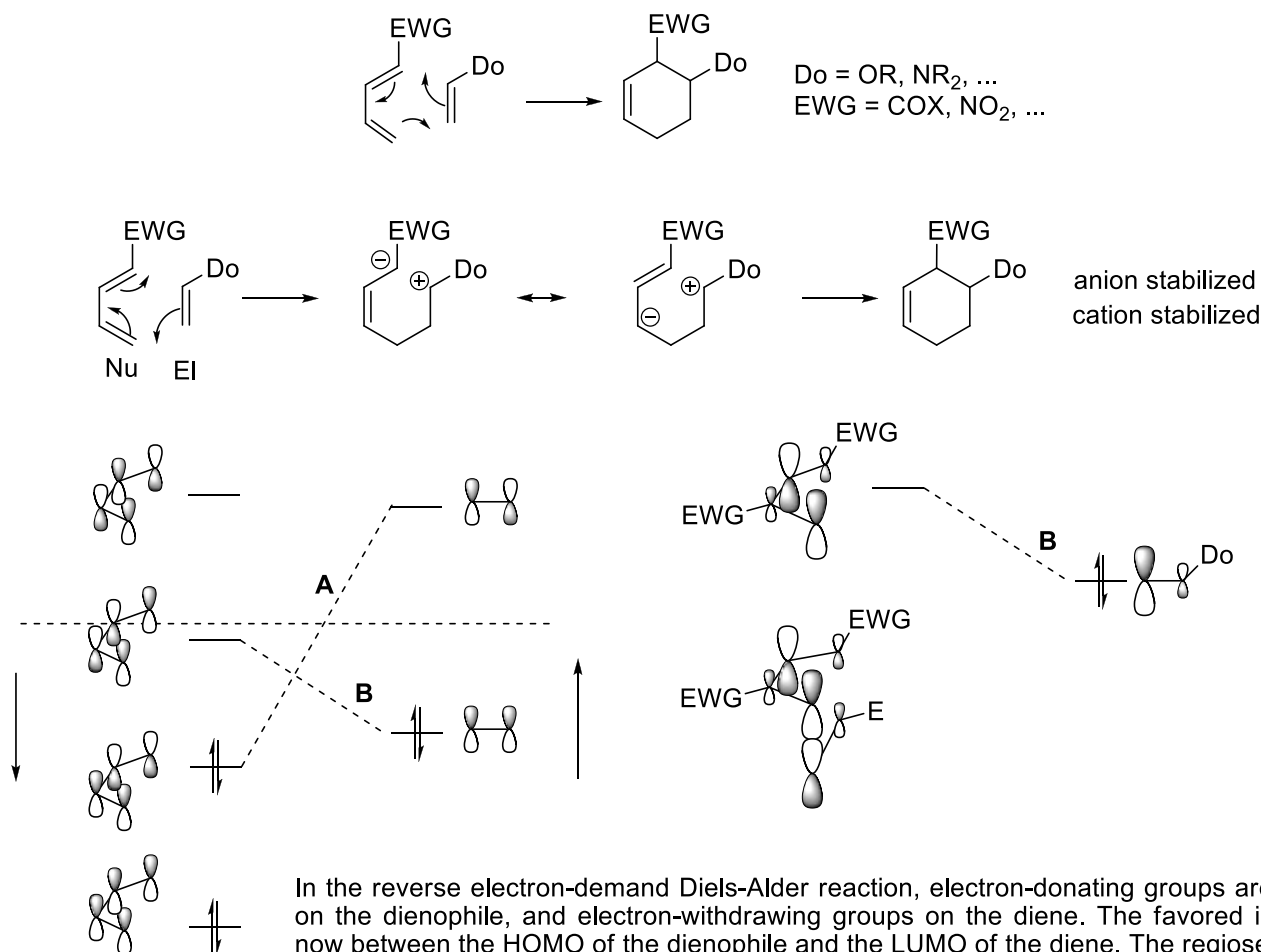

4.3.1.4 Retro-Diels Alder reactions

In principle, retro Diels-Alder reactions are thermodynamically not favorable. However, if very stable compounds are formed, such as aromatic compounds, N_2 or CO_2 , the reaction can become favorable. Particularly useful are Diels-Alder retro Diels-Alder sequences.

Pyrones as dienes

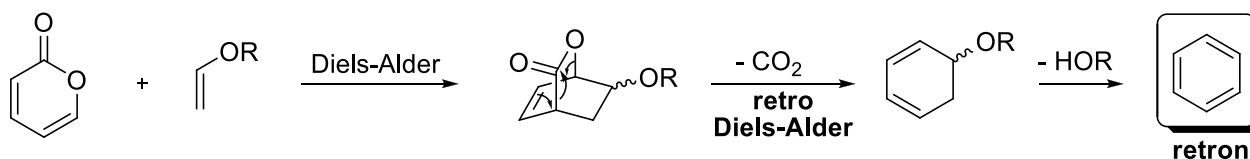

The use of pyrones in a Diels-Alder/retro-Diels-Alder sequence gives an original access to benzene rings. Substituents can be introduced in positions that are usually difficult to functionalize. The first step is a reverse electron demand Diels-Alder cycloaddition between the pyrone and an enol ether for example. The obtained product undergoes a retro Diels-Alder at higher temperature under release of CO_2 . Finally aromatization occurs through elimination of alcohol.

Pyridazines as dienes

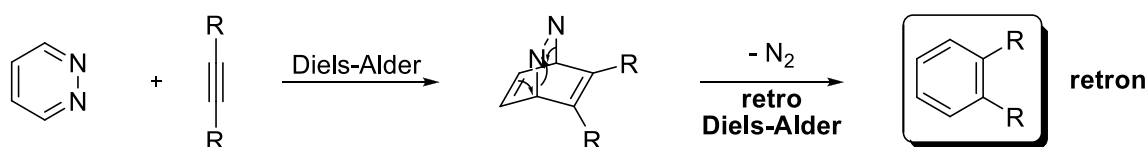

A second possibility for the synthesis of benzene rings is the use of pyridazines as dienes. The presence of the two heteroatoms makes the molecule more reactive and the Diels-Alder reaction with acetylenes becomes possible, especially in an intramolecular way. A retro Diels-Alder reaction with release of N_2 gives then the benzene ring. This method has been used especially by Dale L. Boger in natural product synthesis.

4.3.1.5 Hetero Diels-Alder reactions

Carbonyls and imines as dienophiles

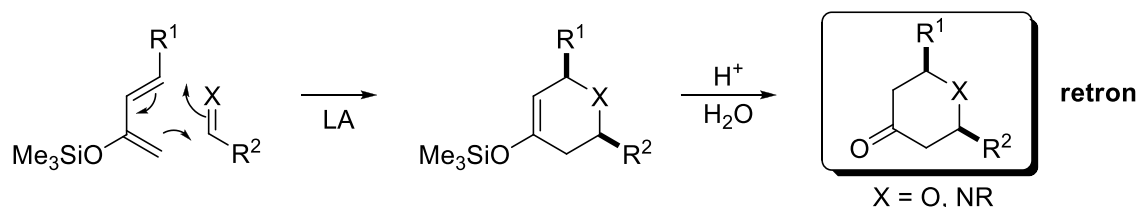

The introduction of an electrophilic heteroatom such as N or O in the dienophile makes this one more electron-deficient. The effect on the orbitals is comparable to the introduction of an electron-withdrawing group. Again, the binding of a Lewis acid to the oxygen or nitrogen accelerates the reaction. The obtained enol ethers can be hydrolyzed to give pyranones or piperidinones, which are important building blocks for medicinal chemistry or total synthesis.

stepwise process

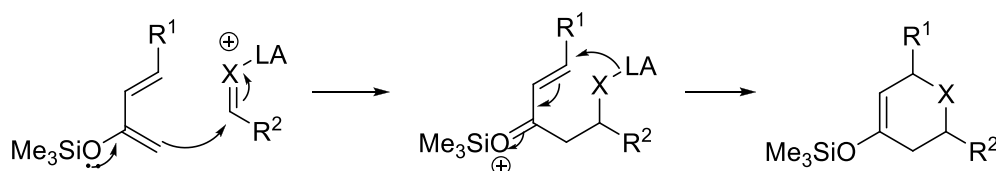

In the hetero Diels-Alder reaction, the polarization can become so strong that the reaction becomes stepwise: first a Mukaiyama aldol reaction, then a hetero-Michael addition. In this case, the diastereoselectivity observed can be different, as the mechanism is not concerted any more.

Inverse Electron-Demand Hetero Diels Alder Reactions

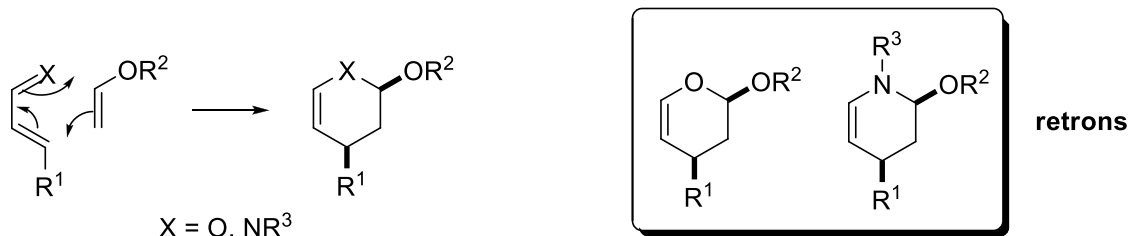

It is also possible to introduce the hetero atom on the diene. In this case, the diene becomes much more electrophilic and inverse electron-demand Diels-Alder reactions are favored. The obtained products are useful dehydro pyrans and piperidines.

Nitroso Diels-Alder reaction

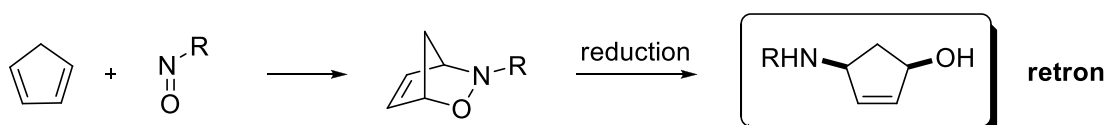

Nitroso compounds are also good dienophiles. As the obtained N-O bond is easy to reduce, this method allows the simultaneous introduction of amines and alcohols in organic molecules.

Vogel's SO₂ Diels-Alder reaction

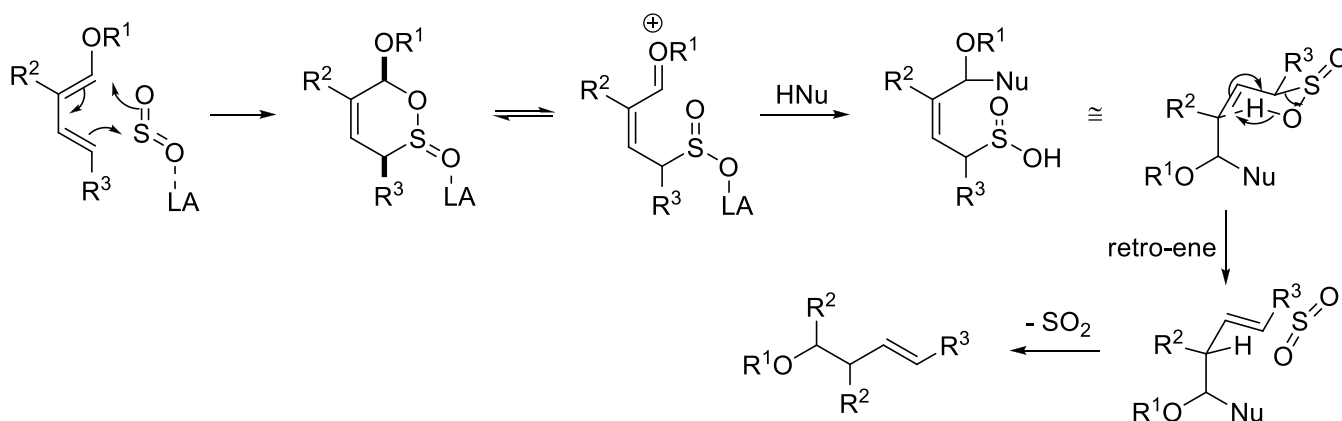

The potential of SO₂ in Diels-Alder reactions was especially studied by Prof. Pierre Vogel at EPFL. The formed Diels-Alder product contains an electrophilic oxonium, that can react with nucleophiles, in particular silyl enolates. After protonation, the obtained allylic sulfonic acid is unstable and undergoes a retro-ene reaction. High selectivities can be obtained in this reaction cascade, due to the cyclic transition states. The absolute chemistry can be controlled by the introduction of chiral auxiliary in R¹ (see lecture).

In addition to the examples presented here, there are naturally many other hetero-Diels Alder reactions that are possible!

4.3.1.6 Stereoselectivity in the Diels-Alder reaction

Control of relative stereochemistry

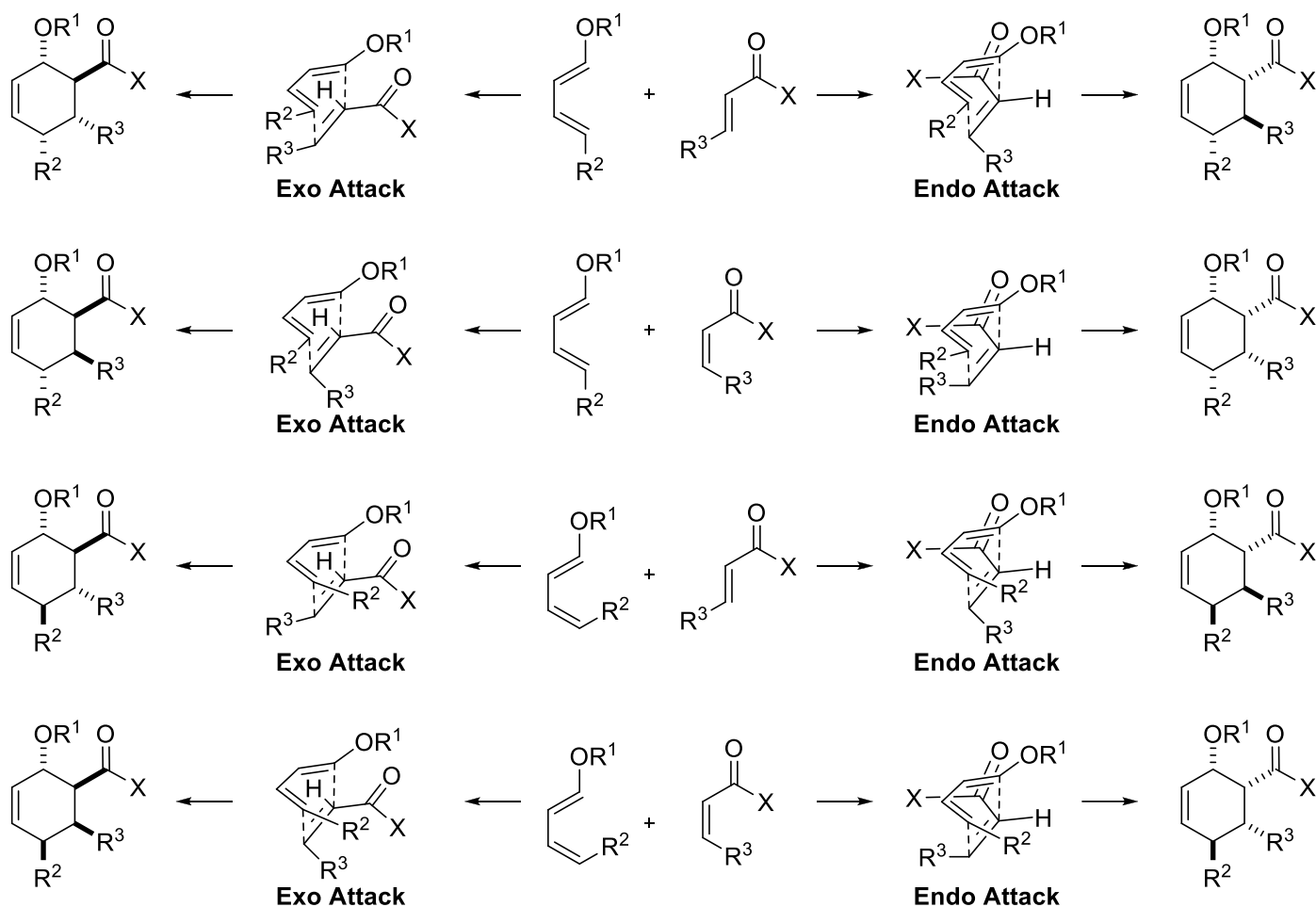

The power of the Diels-Alder cycloaddition is clearly apparent in the analysis of a classical normal electron-demand Diels-Alder reactions. Due to the concerted transition state, the geometry of the double bonds is transferred to the chirality of the formed centers (the reaction is stereospecific). The relationship between the groups on the diene and on the dienophile is further determined by the endo vs exo transition state. Generally, the endo transition state is electronic favored (see section 4.3.1.1), but the exo transition state is often sterically more favored. In particular if very bulky Lewis acids are used, the exo transition state can become favored. Furthermore, lower endo selectivity can be expected for *cis* dienophile with bulky R² group (unfavorable steric interactions).

Induction of diastereoselectivity with chiral centers

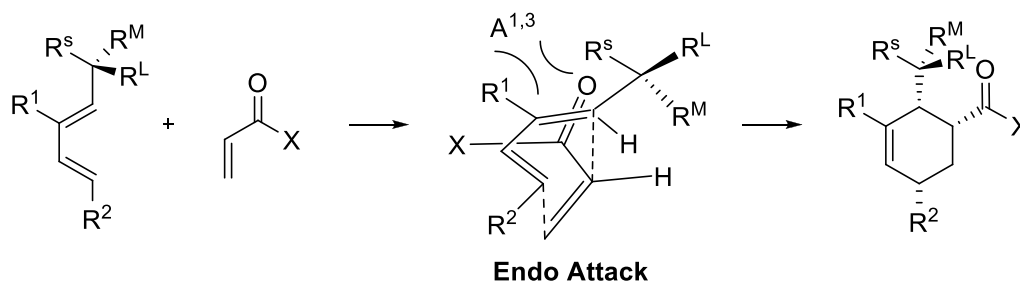

Good stereoselection can be observed if stereocenters are present on the diene. In this case, the A^{1,3} interaction is minimized and the dienophile comes towards R^M (medium) and not R^L (large). As expected, the selectivity is higher if the R¹ substituent is large (stronger A^{1,3}).

Uses of chiral auxiliaries

A/ Evans auxiliary

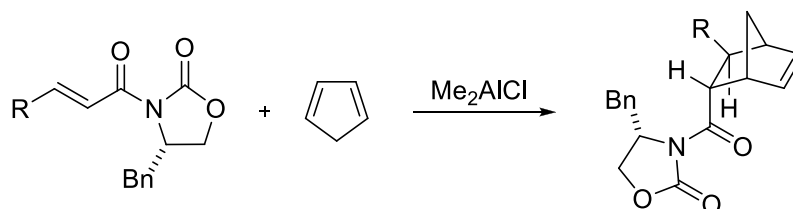

2 Different models depending of stoichiometry of Lewis Acid:

1 Eq. Me_2AlCl : no chelate

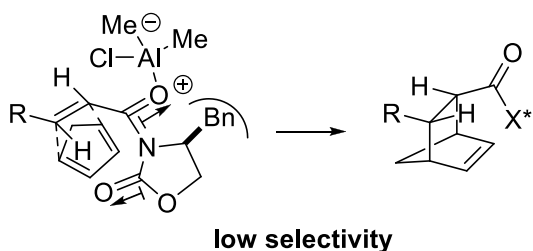

- Endo transition state
- Minimize dipole with oxazolidinone
- L. A. binds O opposite to bulky Bn group
- Dienophile in *s-trans* conformation
- Diene comes opposite to bulky Bn

2 Eq. Me_2AlCl : chelate

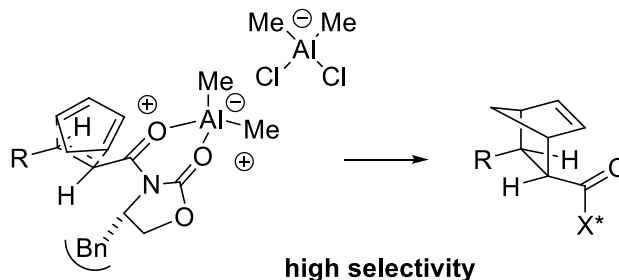

- Endo transition state
- Abstraction of Cl by second L. A. allows chelation
- Dienophile in *s-cis* conformation
- Diene comes opposite to bulky Bn

The Evans auxiliary is again one of the most successful auxiliaries in the case of the Diels Alder reaction. It is introduced on the dienophile and best selectivities were observed with two equivalents of Lewis acid. This was explained by two different transition states in presence of one or two equivalents of Lewis acid. If only one equivalent of Lewis acid is present, the reaction proceeds via single binding of the carbonyl group. The dipoles are minimized and the Lewis acid is bound opposite to the bulky Bn group. Because of the Lewis acid, the olefin is in the *s-trans* conformation. Finally the diene attacks opposite to Bn. The selectivity is not very good, because the Bn group is far away from the diene. If two equivalents of Me_2AlCl are present, the second equivalent can extract a chloride from the bound Lewis acid. With one more free side, Al is now able to chelate the oxazolidinone. To limit the interaction with the bulky Bn group, the olefin is now in the *s-cis* conformation, especially now that the Lewis acid is bound on the other side of the carbonyl. In this case, the Bn group is much closer to the olefin and the diene attacks the opposite face with good selectivity. It is important to see that the major product obtained is identical in both cases, because both the face of attack and the conformation of the olefin have changed! The Evans auxiliary is easy to introduce and to remove (see chapter 2).

B/ Chiral menthol esters

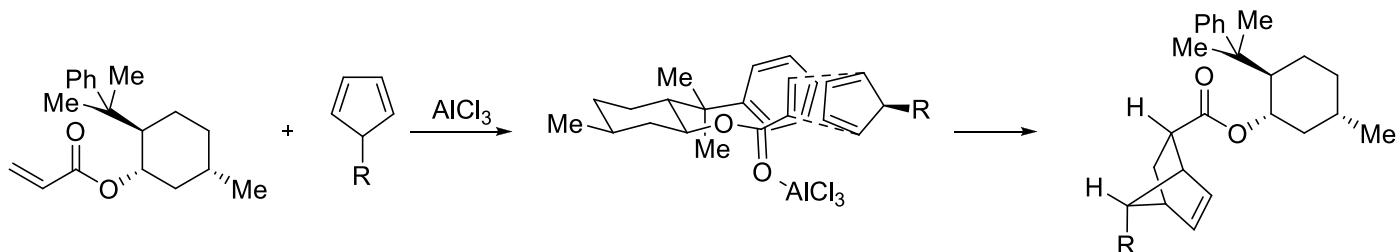

Chiral esters derived from phenyl menthol are also good chiral auxiliaries. In this case, the dienophile is blocked in a conformation by pi-stacking interaction with the phenyl ring of the auxiliary. The endo attack of the diene minimizing the interaction with the R group is favored.

C/ Other Auxiliaries for the dienophile

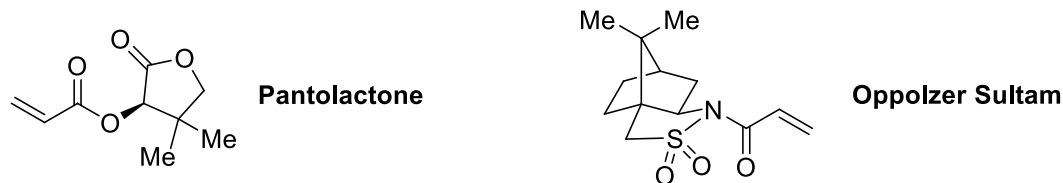

Many other chiral esters or amides have been also used as chiral auxiliaries. Among them, Pantolactone and Oppolzer's Sultam (University of Geneva) have been especially successful.

D/ Chiral ethers for the diene

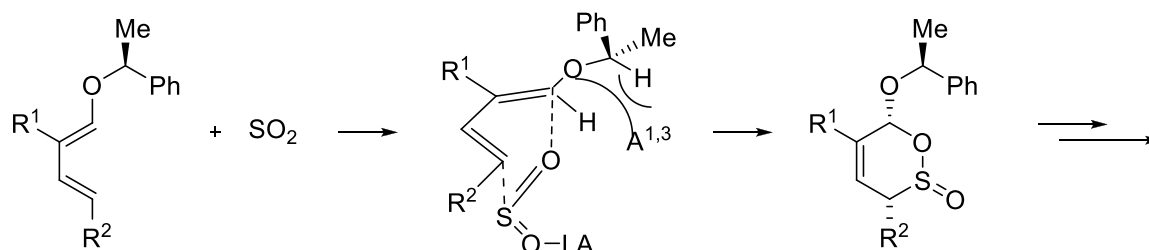

The use of chiral auxiliary on the diene has been less often examined. For example, Vogel used chiral ethers as auxiliaries for the hetero-Diels-Alder reaction with SO_2 . In this case, $A^{1,3}$ interactions were minimized and the dienophile attacks opposite to the larger phenyl group.

Special case: the intramolecular Diels-Alder reaction

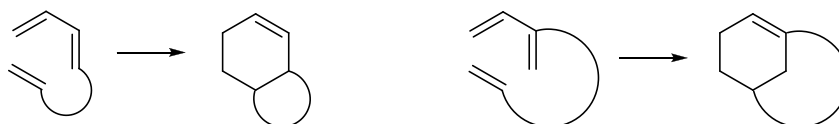

The intramolecular Diels-Alder reactions are especially important in the synthesis of natural products, as they give access to complex carbocyclic structures. For this reason, they have often been used as key steps in particularly elegant syntheses. An advantage of the intramolecular reaction is the entropy gain, that allow to use even non-activated dienes and dienophiles. The rigidity induced by the linker can lead to high selectivity, but there is no general model and the conformation of the molecule has to be studied in a case to case basis.

4.4.2 [3+2] Cycloaddition reactions

Bibliography: Carey-Sundberg, A, Ch. 10.3, p. 873-888; B, Ch. 6.2, p. 526-538. Brückner, Ch. 15.5, p. 674-691.

4.3.2.1 1,3-Dipoles

Important 1,3-dipoles

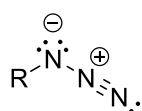

Azide

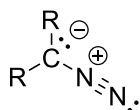

Diazo

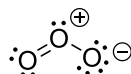

Ozone

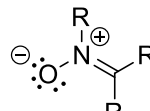

Nitronium

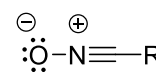

Nitrile Oxide

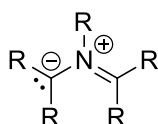

azomethine ylide

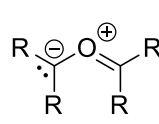

carbonyl ylide

General Mechanism

Polar intermediates

A: nucleophilic dipole, electron-poor olefin

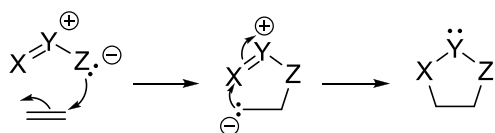

B: electrophilic dipole, electron-rich olefin,

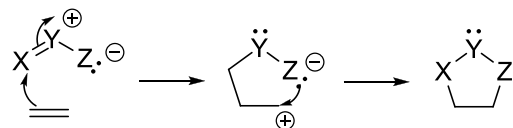

Most [3+2] cycloadditions involve the reaction of 4 electrons in the dipole, and 2 electrons in the olefin. It is similar to a Diels-Alder in which one double bond has been replaced by a lone pair. Again, the role of nucleophile and electrophile is dependent of the atoms and substituents, and the reaction can be described using polar models or orbitals.

Orbitals

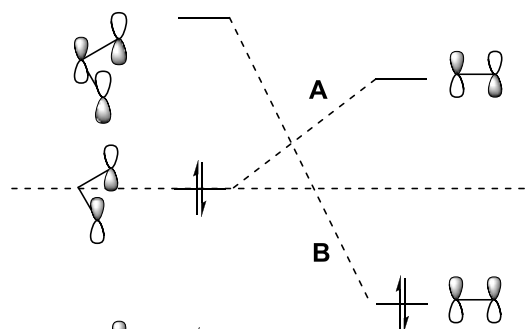

6 electrons in transition state aromatic



A: nucleophilic dipole, electron-poor olefin
HOMO dipole, LUMO olefin

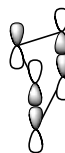

B: electrophilic dipole, electron-rich olefin,
LUMO dipole, HOMO olefin

Supra cycloaddition

Synthetic Applications

A/ Ozonolysis

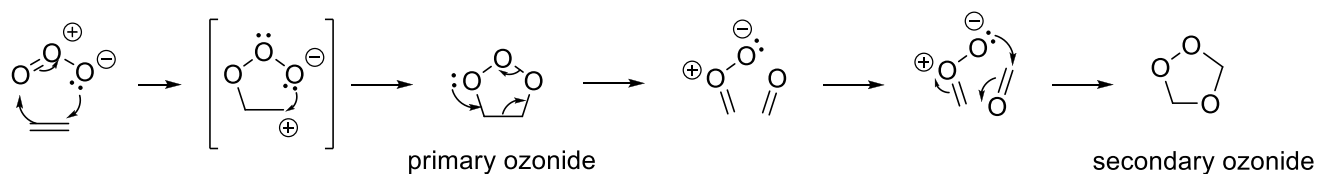

Reductive work up

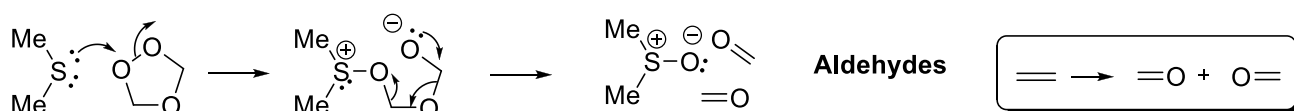

Oxidative work up

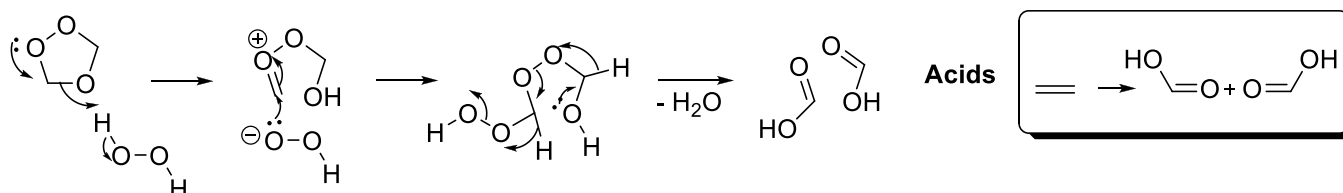

The ozonolysis is one of the classical reactions of organic chemistry. The mechanism is fascinating and involves two [3+2] cycloadditions. Ozone is electron-poor, due to the electronegativity of the three oxygens and reacts faster with electron-rich olefins. The formed primary ozonide is unstable and undergoes a retro [3+2] cycloaddition to form a carbonyl oxide and an aldehyde, which then recombine to form the secondary ozonide. Under reductive conditions (Me_2S , NaBH_4 , PPh_3) the aldehydes are obtained, and under oxidative conditions (H_2O_2) the acids.

B/ Azide-Alkyne cycloaddition (Huisgen cycloaddition)

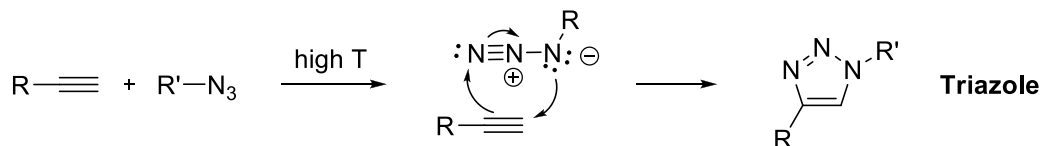

Sharpless: At room temperature with Cu catalyst = example of Click Chemistry

Click chemistry: ideally: easy atom-economical reaction, without waste generation, with high tolerance towards impurities and functional groups, at room temperature under physiological conditions (water, air neutral pH).

Very interesting properties the Cu-catalyzed cycloaddition of azides and acetylenes: it can be performed in the presence of virtually any other functional groups and azides, and to a lesser extent acetylenes, are absent in biomolecules: this reaction is ideally suited for the synthesis of bioconjugates. In contrast to ozone, azides are stable compounds at room temperature. The cycloaddition is slow, but can be accelerated with Cu catalysts.

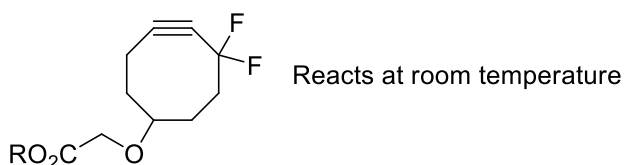

Carolyn Bertozzi in Berkeley introduced strained cyclooctyne as substrates. Due to the ring strain, the cycloaddition takes place at room temperature even without catalyst. This allowed the functionalization of substrates in living cells without the use of toxic Cu catalysts.

C/ Nitrile oxides: Aldol equivalents

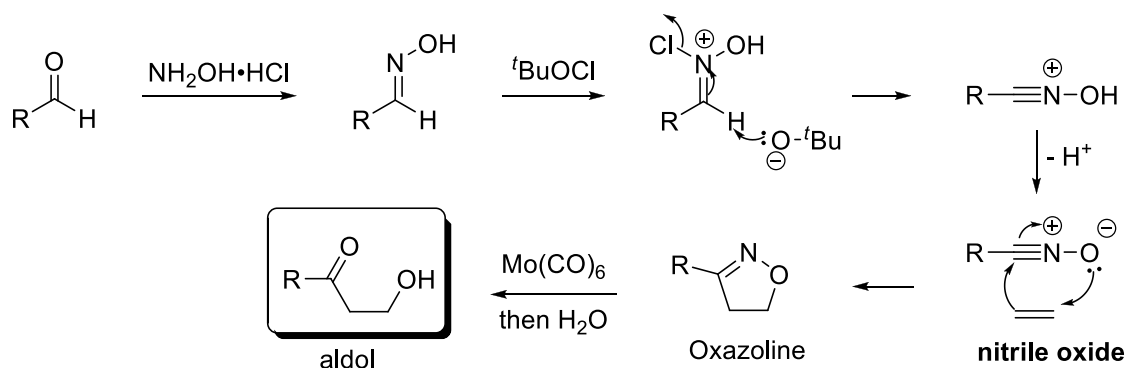

Nitrile oxides are very reactive 1,3 dipoles, which need to be prepared *in situ* via the oxidation of oximes with *tert*-butyl hypochlorite. The resulting deep blue nitrile oxides react already at low temperature with olefins to form oxazoline heterocycles. The weak N-O bond can be reduced, for example with Molybdenum hexacarbonyl to form the corresponding aldol products after hydrolysis. The cycloaddition of nitrile oxides with olefins can consequently be considered as a synthetic aldol equivalent, which gives the aldol product as a protected oxazoline.

D/ Azomethine Ylides: pyrrolidines.

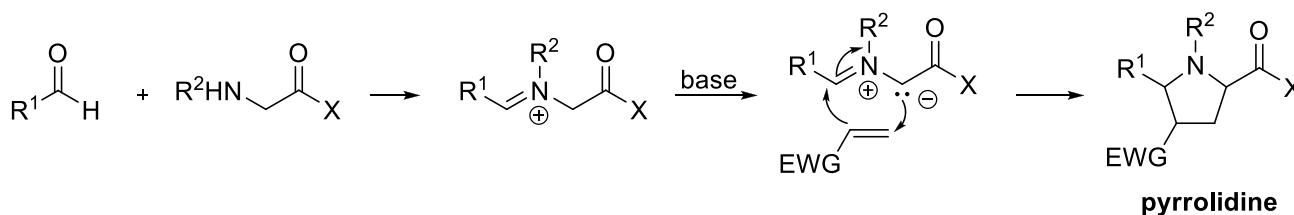

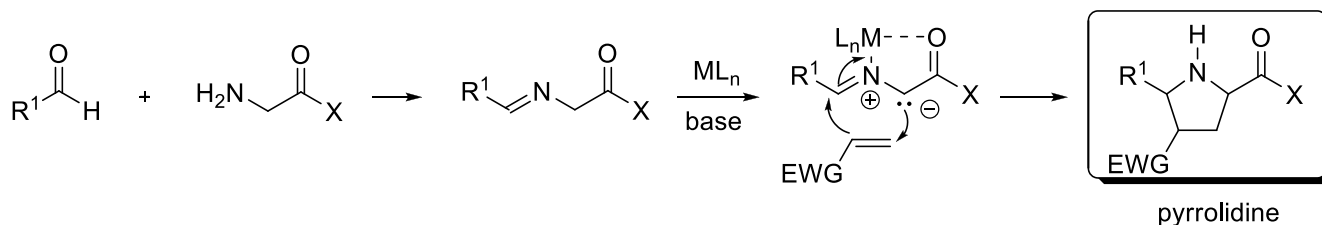

Azomethines ylides are prepared by the condensation of an aldehyde with a secondary alpha amino carbonyl, followed by deprotonation. They react best with electron poor olefins with good regioselectivity. If a primary alpha carbonyl group is used, further activation with a Lewis acid catalyst is required, which allows also for the use of chiral catalysts (see lecture catalytic asymmetric reactions in organic synthesis). The obtained pyrrolidines are important building blocks for the synthesis of natural products and drugs.

E/ Carbonyl ylides

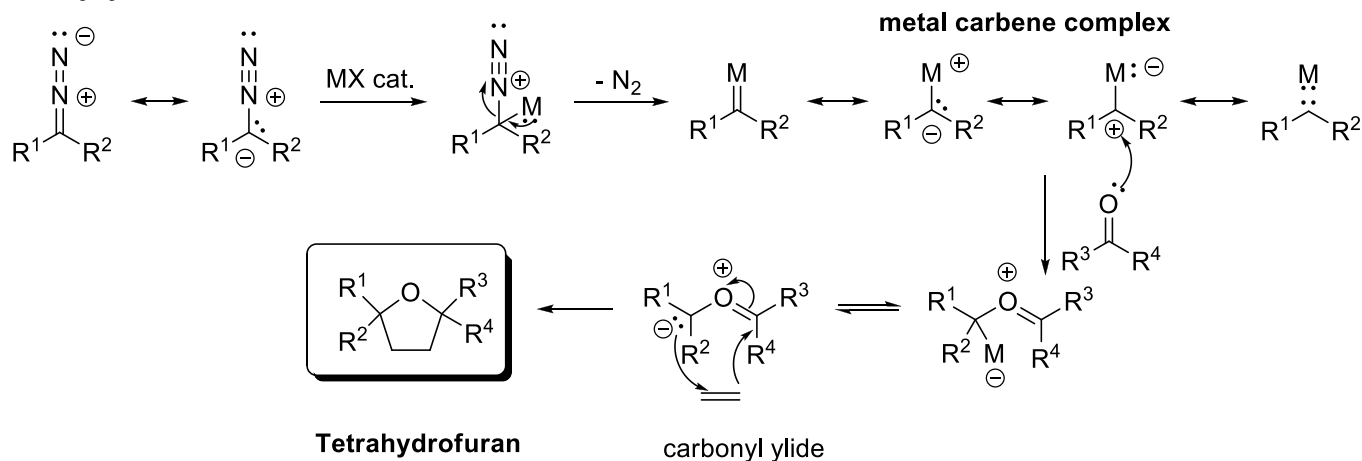

In analogy to azomethine ylides, the reaction of carbonyl ylides with olefins gives tetrahydrofuran rings. However, carbonyl ylides are much less stable and more difficult to synthesize. A good method is the reaction of metal-bound carbenes (generated from the corresponding diazo compounds) with carbonyls. With the adequate metal (for example rhodium) the formed electrophilic carbene can then react with the oxygen of the carbonyls to form the ylide. This reaction works best intramolecularly.

F/ Corey-Winter reaction: retro-cycloaddition

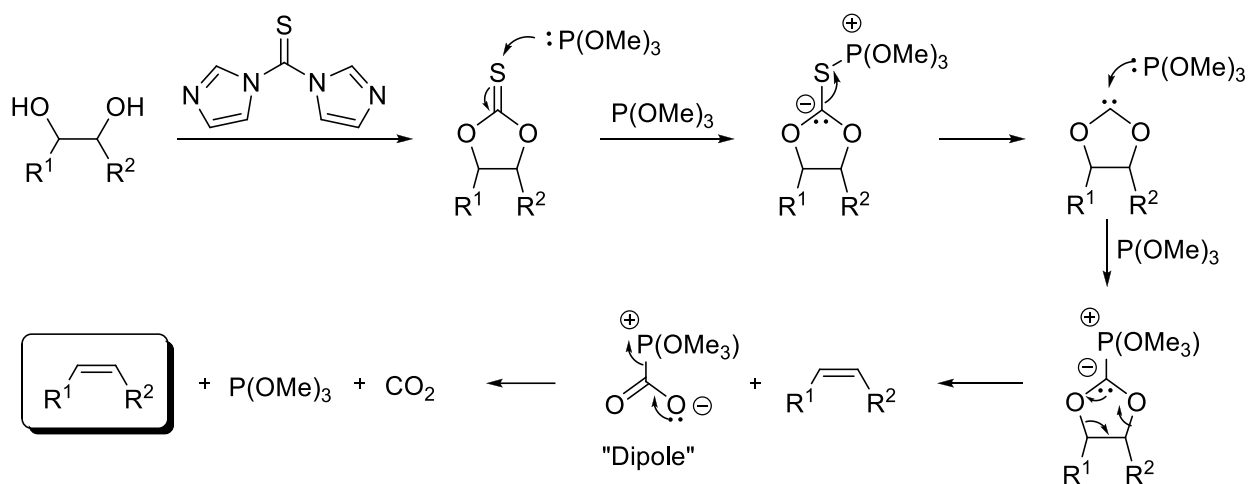

The Corey-Winter reaction is a method for the transformation of diols into olefins. In the first step, a thiocarbonate is formed through the reaction with thiocarbonyldiimidazole. The thiocarbonate is then reduced by a phosphite to give a carbene intermediate, which usually reacts with the phosphite to form a ylide. At this point, a formal retro [3+2] cycloaddition takes place to give the olefin and a CO₂-phosphite adduct, which decomposes to give the phosphite and carbon dioxide, driving the reaction forwards.

4.4.3 Other Cycloadditions

Bibliography: Carey-Sundberg, B, Ch. 10.2, p. 903-956. (carbenes). Evans, lecture 9, 9B, 12B, 33-35. Brückner, Ch. 3.3.1-3.3.2, p. 109-118. Carreira, Ch. 15, p.483-515.

4.4.3.1 Cheletropic reactions

Definition: cheletropic cycloaddition: Cycloaddition in which one of the partner reacts with a single atom.

A/ Cyclopropanation

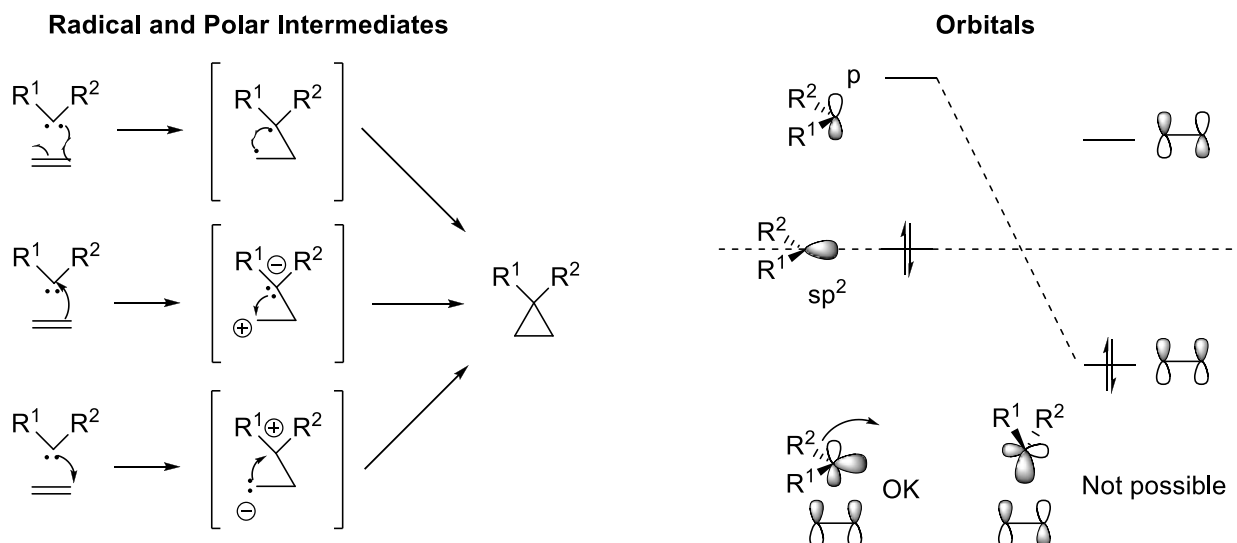

The cycloaddition of carbenes and double bonds can be described easily using biradicals or polarized intermediates. The use of orbitals in this case is more difficult, as a direct linear approach is "forbidden" because of the orbital symmetry. A side-on approach followed by rotation can explain a concerted process, however.

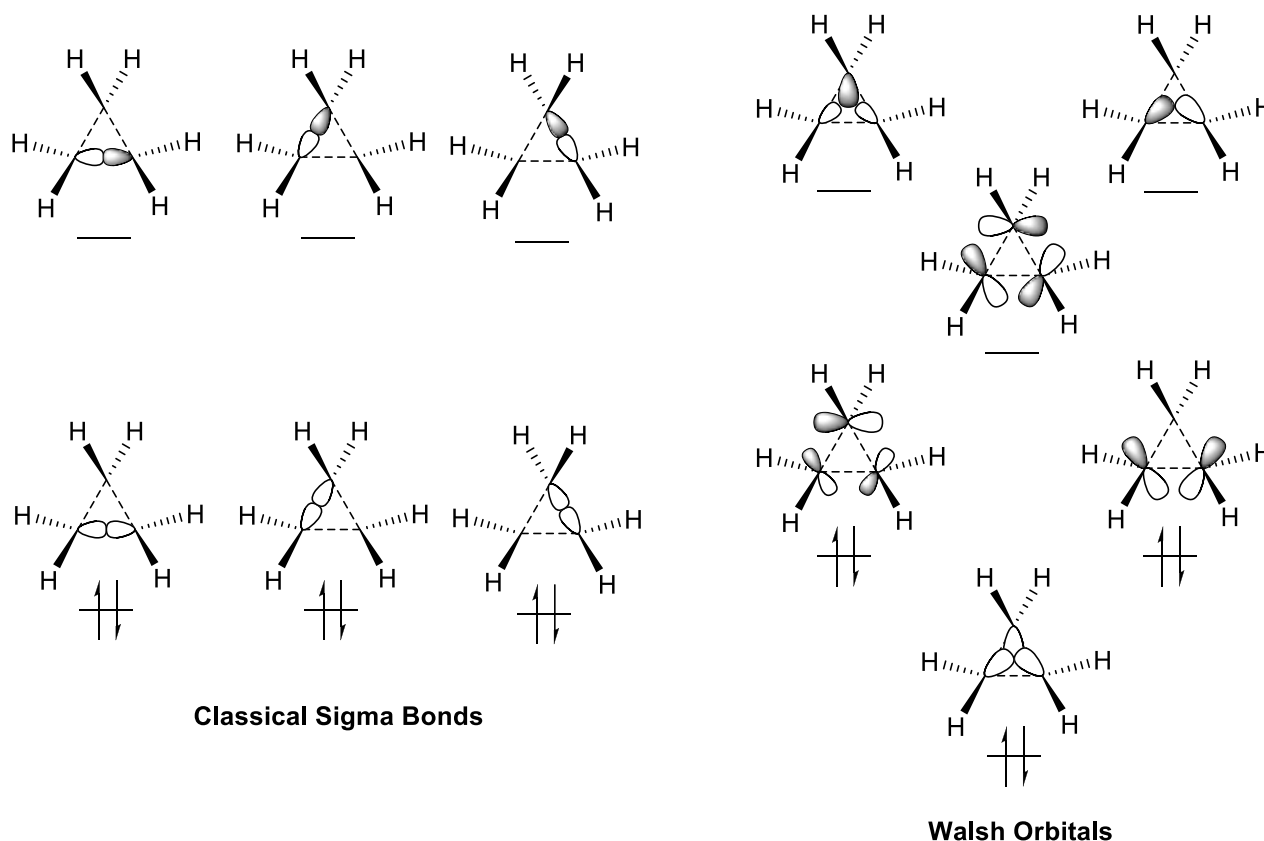

The use of classical sigma bonds is often not enough to describe the properties of cyclopropanes, as in fact differences in energy are observed between the electrons. A better model is the Walsh model, which can be obtained by the combination of three carbene fragments to form the cyclopropane.

Synthetically important cyclopropanation reactions

A.1/ Dichlorocarbenes

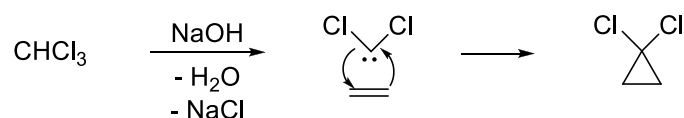

Dichlorocarbenes are easily synthesized in situ from chloroform in presence of a base (Often NaOH under phase transfer conditions). They react easily with double bonds to form dichlorocyclopropanes.

A.2/ Corey-Chaykovsky cyclopropanation

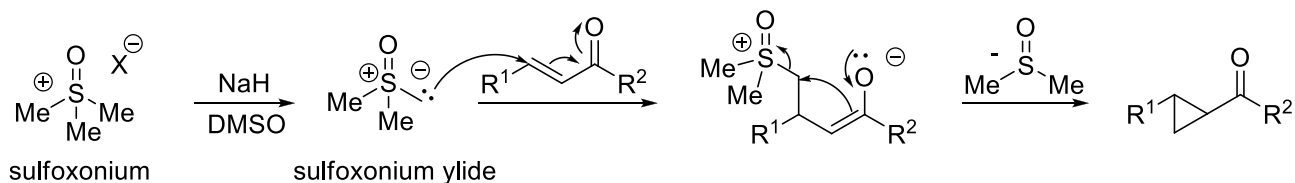

The Corey-Chaykovsky cyclopropanation reaction is not a concerted cycloaddition, but a stepwise process. The first step is the nucleophilic addition of a sulfonium ylide onto an electron-deficient olefin. In the second step, an intramolecular 3-exo-tet substitution reaction gives the cyclopropane upon release of dimethylsulfoxide.

Corey-Chaykovsky epoxidation

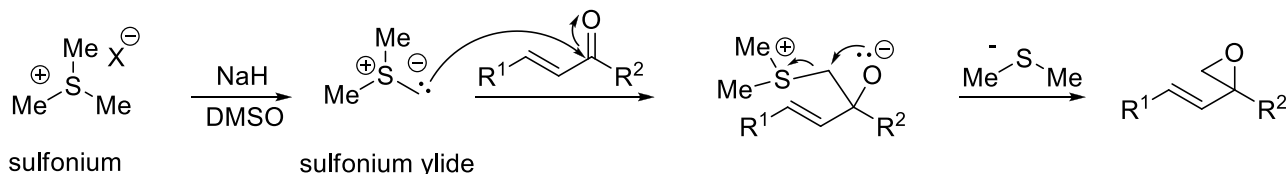

When more reactive sulfonium ylides are used, the reaction becomes faster and charge-controlled, and the 1,2- addition is favored. Intramolecular attack of the oxygen with release of dimethyl sulfide then gives the epoxide as product.

A.3/ Simmons-Smith Cyclopropanation

original method

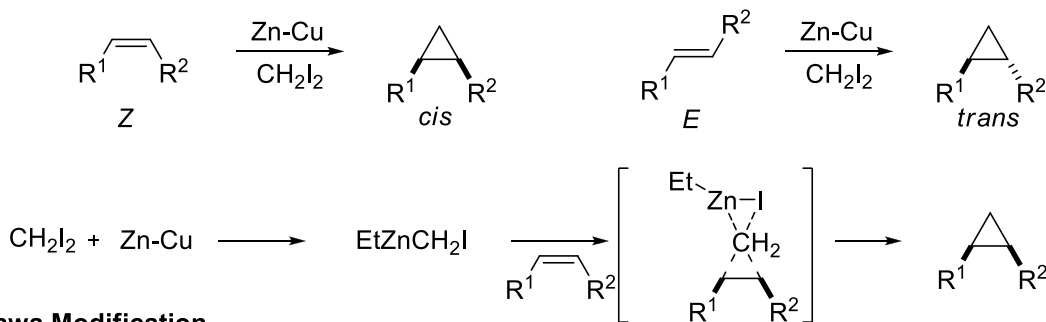

Furukawa Modification

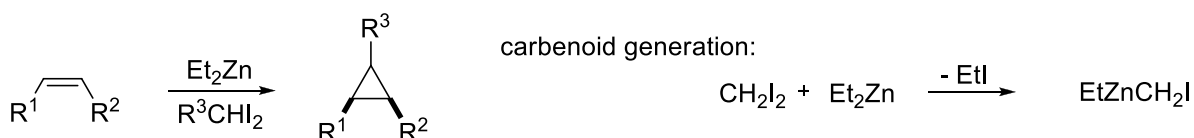

The Simmons-Smith cyclopropanation is a very general cyclopropanation method based on Zinc carbenoids. In the original procedure, the carbenoid is formed by insertion of Zn in the C-I bond of diiodomethane. The reactive intermediate then reacts with the double bond in a concerted transition state to form the cyclopropane. The reaction is stereospecific (*Z* olefins give *cis* products, and *E* olefins give *trans* products) and the formed carbenoid is electrophilic, so that electron-rich double bonds react faster. In the more convenient Furukawa modification, the reactive carbenoid is generated from diethylzinc via Zn-iodine exchange. This more practical protocol is also more general in respect of the diiodide and is more often used in synthesis.

Directed Simmons-Smith cyclopropanation

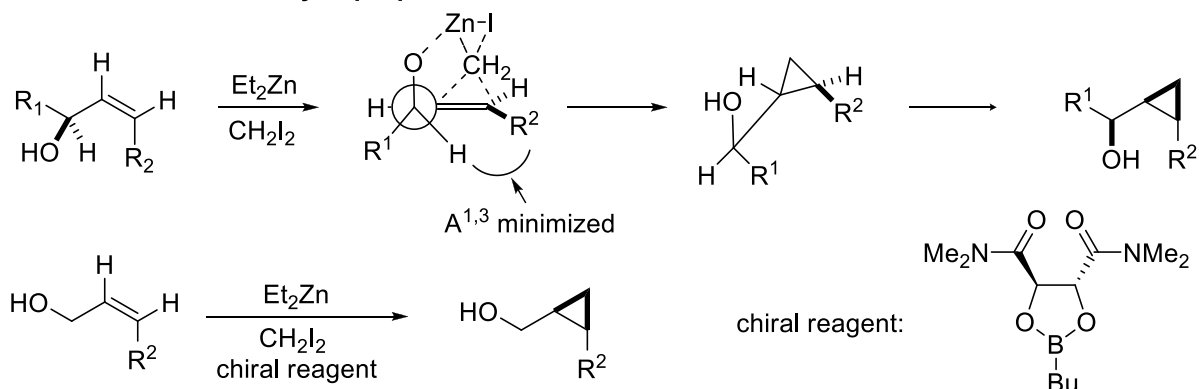

Like epoxidation reactions, the Simmons-Smith cyclopropanation can be directed by an alcohol group. In the transition state, the Zn is bound to the oxygen (other structure involving several Zn and Et groups have also been proposed). The minimization of steric strains, such as A^{1,3} interactions, can lead to good stereoselectivity. For achiral substrates, chiral boron reagents derived from tartaric acid have been developed (**Charette reagents**), but they have to be used in stoichiometric amounts.

A.4/ Metal-catalyzed cyclopropanation with diazo compounds

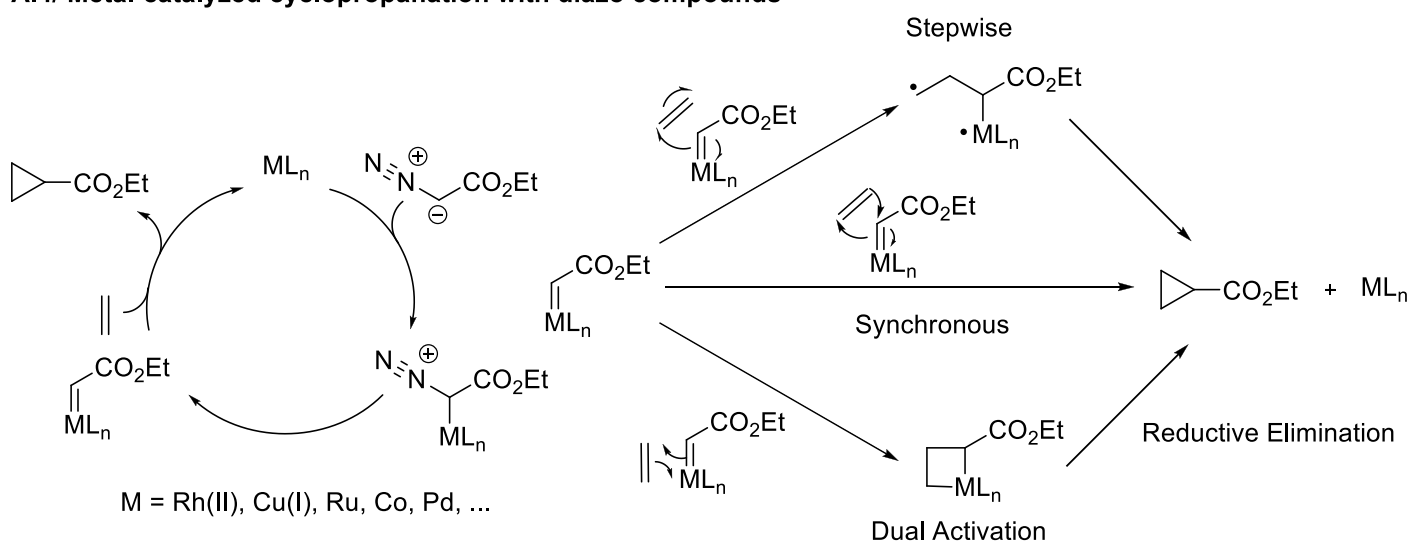

The metal-catalyzed cyclopropanation of olefins using diazo compounds is one of the most versatile methods for the synthesis of cyclopropanes. Two important catalysts are Rh₂(OAc)₄ and CuOTf. The reaction proceeds first via formation of the metal-carbene intermediate (see also chapter 4.4.2 on [3+2] cycloadditions), followed by cyclopropanation of the olefins. The cyclopropanation step can proceed either via a metalacyclobutane intermediate a (metathesis-like mechanism) followed by a reductive elimination, or via a stepwise or synchronous carbenoid mechanism. The reaction can be made asymmetric by the introduction of chiral ligands.

Preparation of diazo compounds

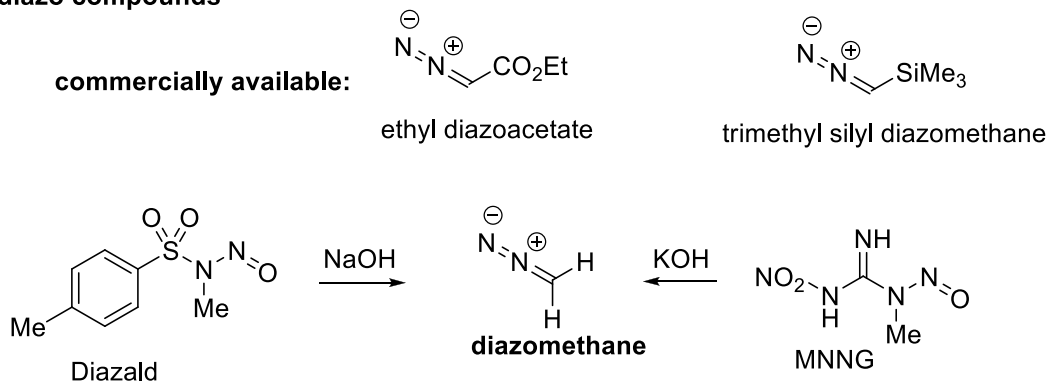

Regitz Diazotransfer

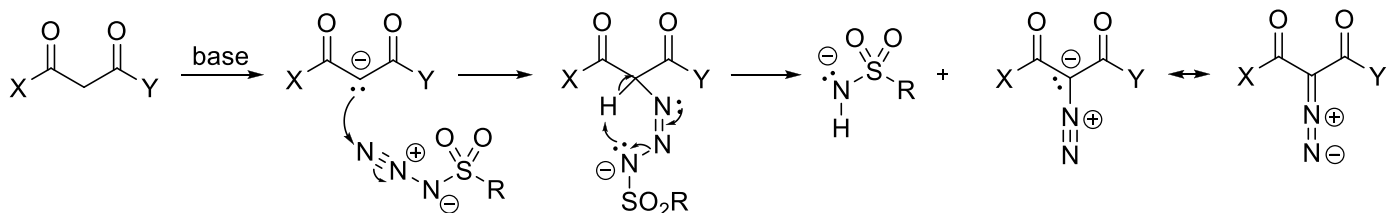

A disadvantage of the metal-catalyzed cyclopropanation of olefins using diazo compounds is the required preparation of the substrates. Only few diazo compounds are commercially available, for example ethyl diazoacetate or trimethylsilyl diazomethane. The simplest diazo compound, diazomethane is highly explosive and has to be prepared immediately before use from the commercially available Diazald (*N*-methyl-*N*-nitroso-*p*-toluenesulfonamide) or MNNG (*N*-methyl-*N*'-nitro-*N*-nitrosoguanidine). For the diazo compounds derived from 1,3 dicarbonyl, the **Regitz method** starting from sulfonamide is used.

Summary of the reactivity of metal-bound carbenes

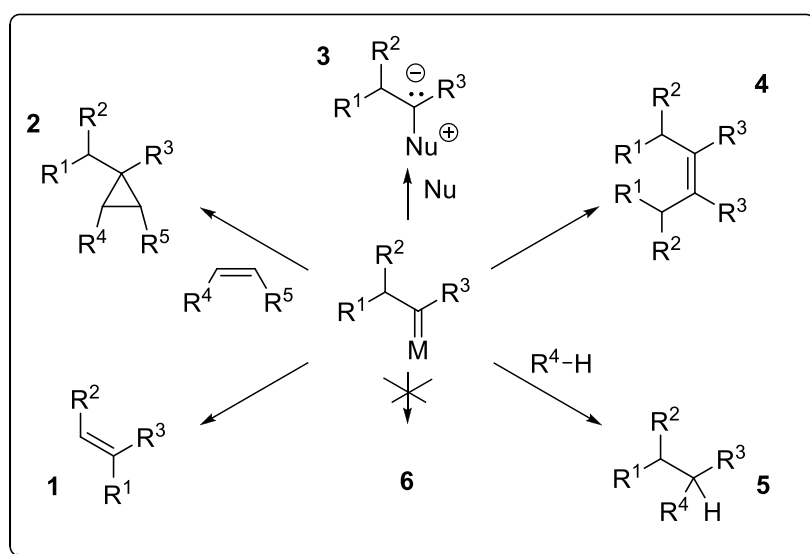

At this point, it is good to summarize the different reactivity possible with metal-bound carbenes. We have already seen 1,2 shift (1), cyclopropanation (2) and addition to nucleophile to form ylides (3, beside carbonyls, imines or sulfur nucleophiles are also possible). Further possible reactions are: dimerization (4), usually an undesired side reaction of cyclopropanation that can be avoided by very slow (syringe pump) addition of the diazo compound; insertion into C-H or X-H bonds (5), a very useful reaction for the direct functionalization of organic compounds; and passive role as spectator ligand (6), in particular in case of *N*-heterocyclic carbenes, which have become very important ligands in catalysis. Many factors are responsible for the chemoselectivity of the reaction (metal, ligand on the metal, structure of the substrate and carbene). The influence of the carbenoid structure on the ratio cyclopropanation/insertion/dimerization is given below.

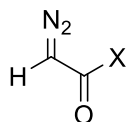

Acceptor carbenoid
Fast dimerization
Tendence towards cyclopropanation

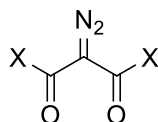

Acceptor-acceptor carbenoid
dimerization
Tendence towards cyclopropanation

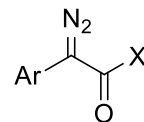

Donor-acceptor carbenoid
Slow dimerization
Tendence towards insertion

C/ 4+1 cheletropic reactions with SO₂

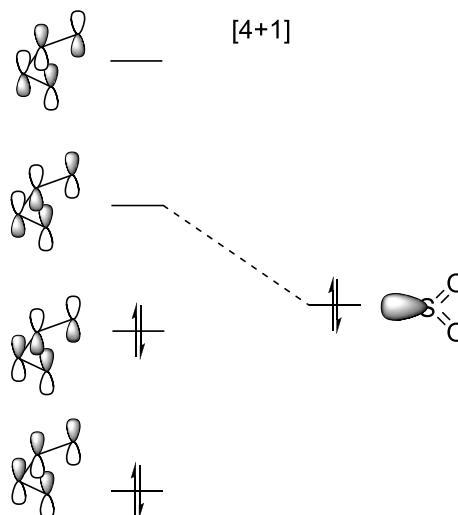
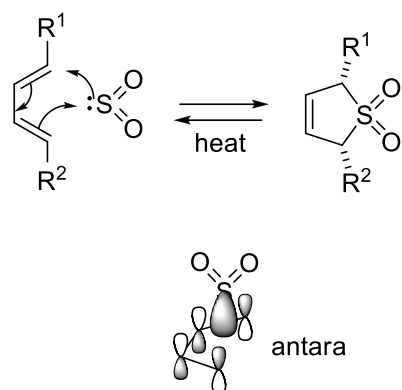

The [4+1] cheletropic reaction of SO₂ with diene is an easy reaction from the point of view of orbitals (antara reaction of SO₂ HOMO with LUMO diene). The retro-cycloaddition becomes favorable at high temperature, as it is entropically driven by the formation of the gas SO₂. For this reason, the reaction has been often used as a protecting group for sensitive dienes, which can then be used in situ in other cycloaddition reactions, for example Diels-Alder cycloadditions.

4.4.3.2 Other cycloadditions

The cycloadditions which have been presented are the most frequently used in organic synthesis. Obviously, other combinations are also possible, such as [4+3], [3+1], [4+4],.... The same principles can be used to analyse these reactions.

5. Radical Methods and Photochemistry

5.1 Principles of radical reactions: initiation, propagation, termination

Bibliography: Carey-Sundberg, A, Ch. 11, p. 965-1073; B, Ch. 10.3, p. 956-992. Brückner, Ch. 1, p. 1-53.

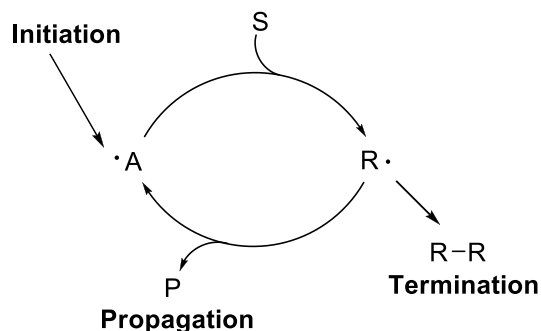

The classical steps of radical reactions are initiation, propagation and termination. In the initiation step, a first radical is generated, which usually reacts with the substrate S to generate a second radical R . R then reacts to generate the product and again a propagating radical (propagation step). In the termination step, the radicals are quenched, often via dimerization reactions.

A/ Reduction using radical reactions.

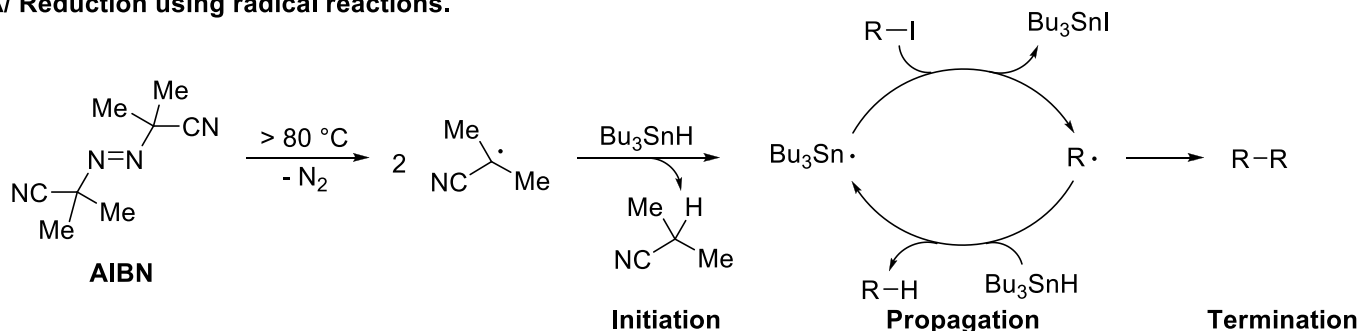

The reduction of iodides is a classical example of radical reaction. The initiation is done using the thermal lability of AIBN (Azobisisobutyronitrile), which decomposes upon heating to give nitrogen gas and two isobutyronitrile radicals. The formed radical makes a H-abstraction from the very weak Sn-H bond (BDE: 74 Kcal/mol) of tributyl tin hydride. The formed stannyl radical can then abstract the iodine atom from the alkyl iodide to give the alkyl radical, which then reacts with tributyl tin hydride to form the reduced product and regenerate the stannyl radical (propagation). Due to the weakness of the Sn-H bond, this process is much faster than any radical termination. Due to the very weak Sn-H bond, tin hydrides are among the best reagents for radical reductions, which is unfortunate, as they are very toxic and difficult to separate from the product.

Modifications:

Initiation

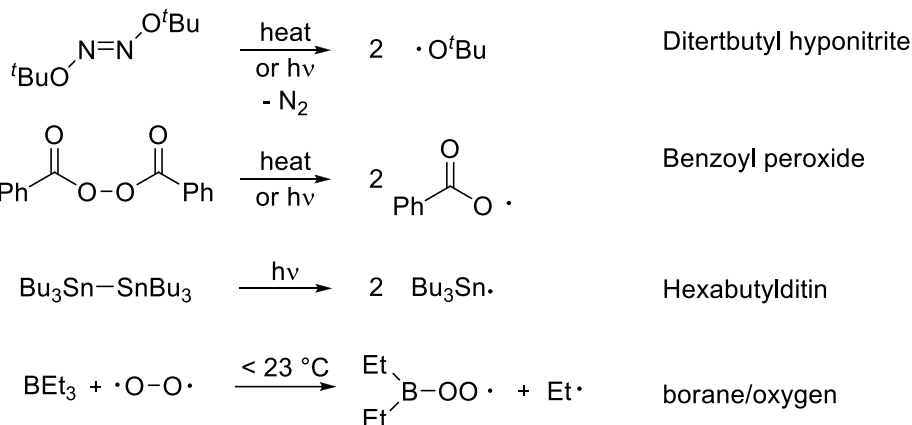

Reductant

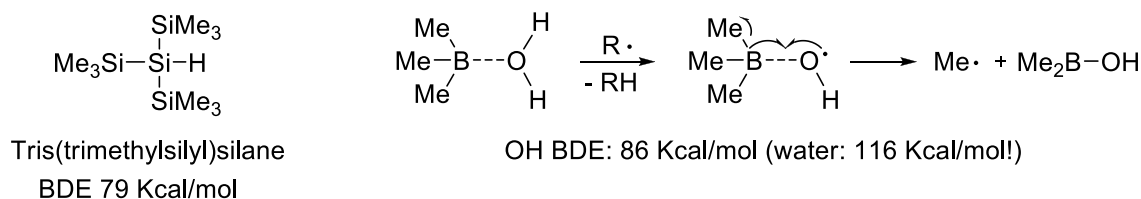

Substrates

Deoxygenation of alcohols: Barton-McCombie reaction

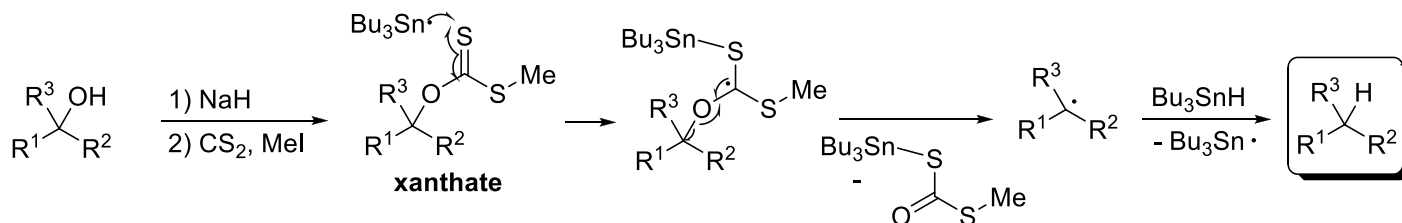

Decarboxylation of acids: Barton decarboxylation reaction

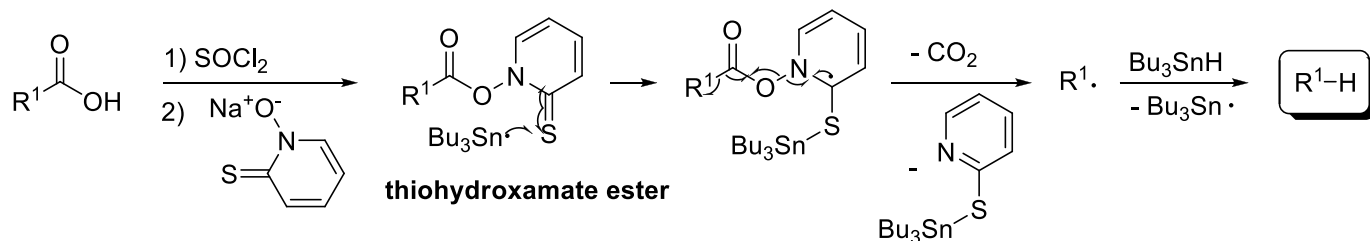

Several variations from the first reaction have been developed:

Initiation: Other initiation methods have been developed. Light can be used instead of heating also with AIBN. Other compounds with weak bonds can also be used for initiation, such as *tert*-butyl hyponitrite, dibenzoyl peroxide or hexamethylditin. Another method makes use of the exceptional reactivity of BEt_3 with oxygen: traces of air at room temperature are already enough to generate alkyl radicals. Different types of radicals are generated with each initiation reagent, leading to different reactivity profiles.

Reductant: Tributyltin hydride is very toxic and substitutes have been examined. One of the most successful one is Tris(trimethylsilyl)silane, but it is more expensive and not as general. Recently, John L. Wood introduced borane-water adduct as reductant: through the binding of BMe_3 to water, the O-H bond is weakened a lot (from 116 Kcal/mol to 86 Kcal/mol) making it a useful reducing agent.

Substrates: Particularly useful are the methods developed by Barton for the deoxygenation of alcohols and the decarboxylation of acids, as these groups are frequent in organic chemistry. The activation of the alcohols proceed via the formation of the xanthate. Addition of the tributyl tin radical is very easy on xanthate, and the alkyl radical for propagation is liberated upon fragmentation of the formed adduct. For the decarboxylation, a thiohydroxamate ester is first formed. Again, the method makes use of the easy addition of the tributyl tin radical onto the C-S double bond. Fragmentation under formation of carbon dioxide and the thiopyridine gives the alkyl radical.

B/ Addition of radicals to double bonds

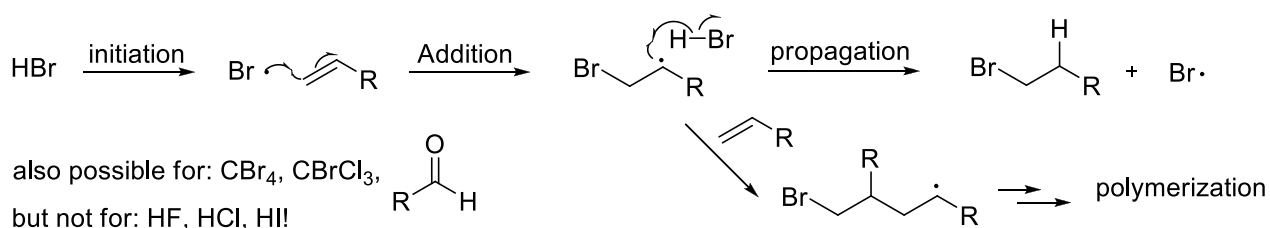

The radical addition of HBr onto olefin is another classical reaction. After initiation with light or a chemical initiator, the formed bromine radical adds to the double bond to give the more stable secondary radical. This radical makes an H abstraction to reform the bromine radical and the addition product. The obtained regiochemistry (anti-Markovnikov) is reversed when compared to the ionic addition of HBr. For the reaction to work, each step has to be favored, which is the case only for few molecules, such as halogeno methanes derivatives and more synthetically interesting aldehydes (BDE (CH) = 88 Kcal/mol). For these reasons, the reaction doesn't work with HF, HCl and HI (The H-F bond is two strong, the H-abstraction cannot take place. For HCl, the abstraction is still very slow, and polymerization of the olefin is faster. For HI, the iodine radical is too stable and doesn't add to the olefin.) Polymerization is often a competing process, which is undesired in organic chemistry, but very useful in polymers science.

C/ Functionalization of aliphatic C-H bonds

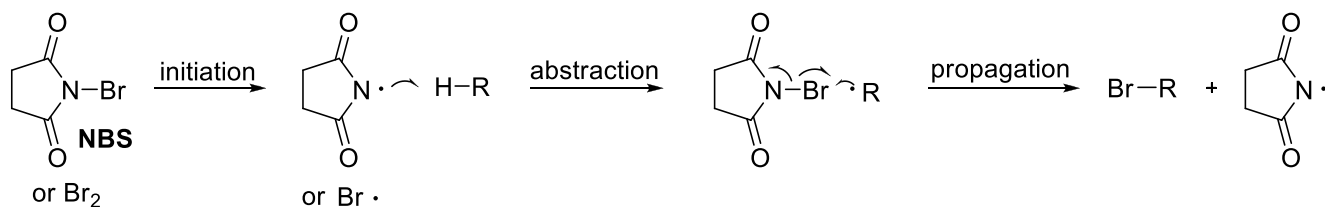

Autooxidation

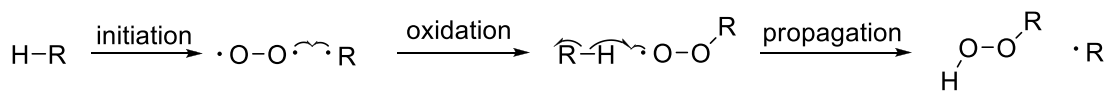

Radical reactions are one of the best way to functionalize directly C-H bonds. Key for success is the use of weak C-H bonds, for which the H abstraction step is possible. The synthetically most important cases are allylic, benzylic C-H bonds and C-H bonds alpha to heteroatoms. A special case is the so-called autooxidation reaction, in which the radical reacts with triplet oxygen to form a peroxide. This can take place spontaneously if weak C-H bonds are present and explain why many organic molecules are sensitive to oxygen. Particularly hazardous is the formation of peroxides on small molecules, as these compounds are explosive. Well known cases in the organic laboratory are diethyl ether and THF, which are usually kept on stabilisers.

Synthetically useful intramolecular cases:

C.1/ Hofmann-Löffler-Freytag reaction

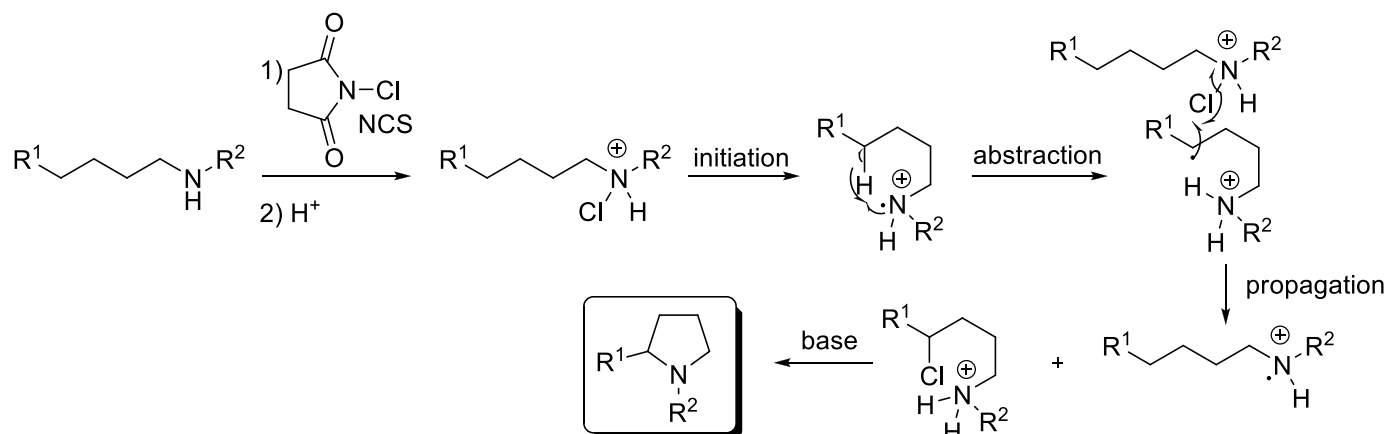

The Hofmann-Löffler-Freytag reaction starts with the chlorination of an amine. The formed N-Cl bond is further labilized by protonation. Initiation with light or a chemical initiator gives a cationic nitrogen radical, which makes a 1,5 intramolecular radical abstraction. As the reaction is intramolecular, even relatively strong C-H bonds can be cleaved. The formed alkyl radical then reacts intermolecularly to abstract a chlorine atom. After treatment with base, an intramolecular substitution reaction takes place to form the pyrrolidine product, an important heterocycle in natural products and drugs.

C.2/ Barton Nitrite Ester Reaction

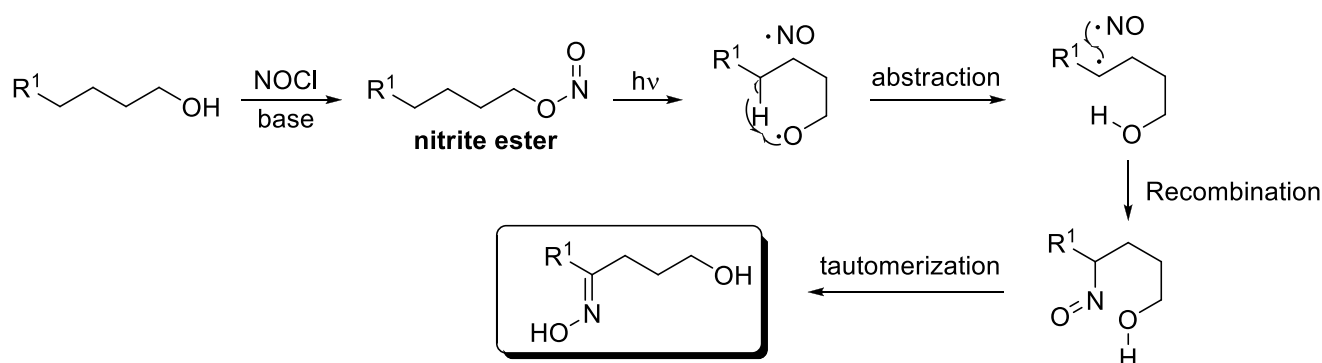

The Barton method is also an intramolecular radical reaction, but not a chain reaction. In the first step, a nitrite ester is synthesized from an alcohol. The weak NO bond is then cleaved under irradiation and the oxygen radical then abstract a hydrogen in 1,5 position. The formed alkyl radical recombines with the NO radical to form a nitroso compounds, which then tautomerizes to the more stable oxime form. The method allows the oxidation of otherwise totally inert C-H bonds, especially in rigid substrates, such as steroids.

5.2 Radical-based cyclization and cascade reactions

cascade = succession of several different reactions in a single process

A/ Addition reduction

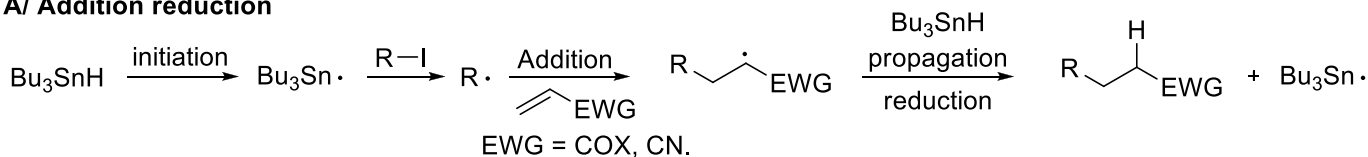

The addition of alkyl radical to double bond followed by reduction with a hydride source is a useful reaction for the formation of C-C bonds. For the reaction to be efficient, it is necessary that the reduction of the first formed radical R is slower than its addition to the double bond. This is usually achieved by using double bonds activated by electron-withdrawing groups.

B/ Allylation

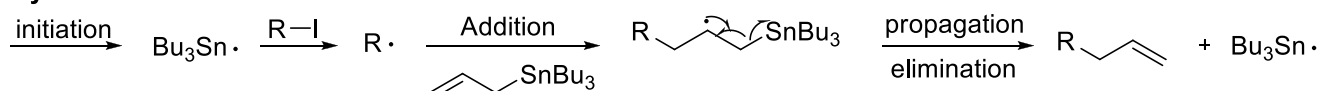

The use of allylstannane allows the allylation of alkyl iodide under radical conditions.

C/ Carboazidation

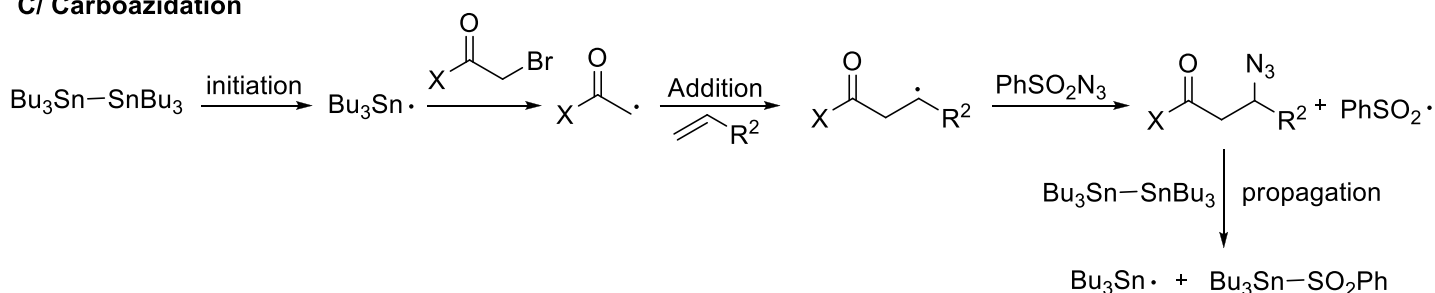

The carboazidation reaction was developed by Philippe Renaud (University of Bern, *Chem. Eur. J.* **2004**, *10*, 3106). The reaction starts with the addition of a radical to an olefin, followed by the azide transfer from a sulfonyl azide. The formed sulfonyl radical can then react with hexamethylditin to regenerate the tributyl tin radical. For the reaction to work, it is necessary to use an alkyl radical substituted with an electron-withdrawing group, to slow down the unwanted direct azidation reaction. The reaction also works with iodide and bromide, but the alkyl iodide is first formed as the product, which then reacts again with the tributyl tin radical to form a new radical which is then azidated. The obtained azides are easily reduced to the amines for the synthesis of natural products and bioactive compounds.

D/ Radical Cyclization

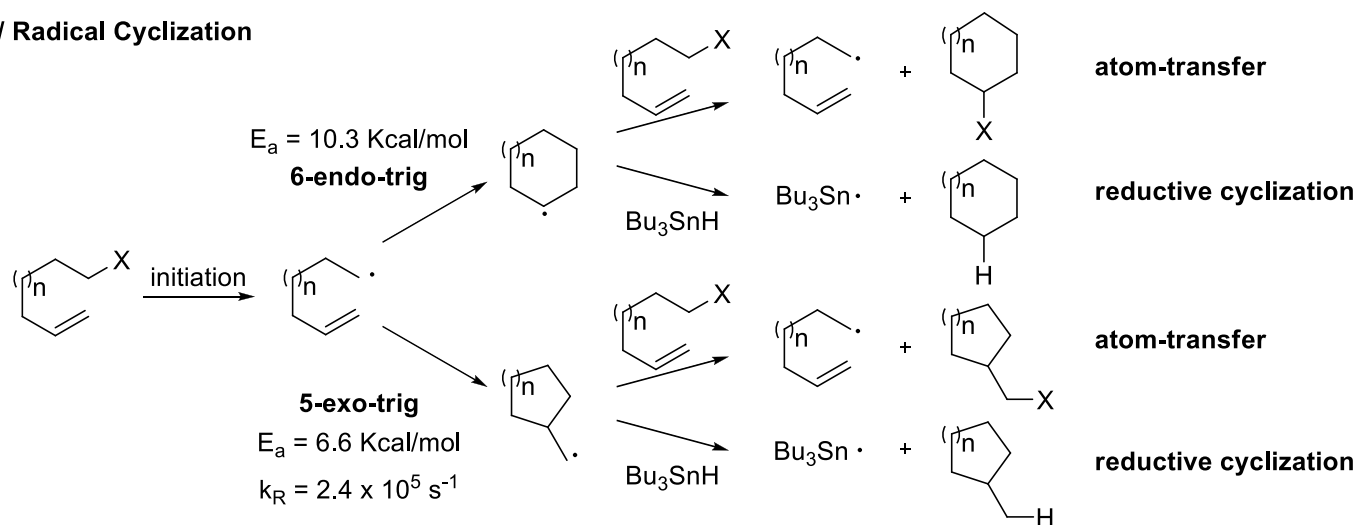

Transition states

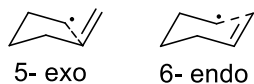

Other Activation Energies

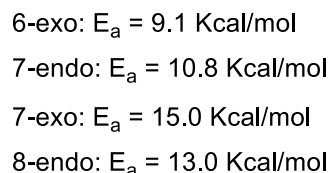

Substituent effects

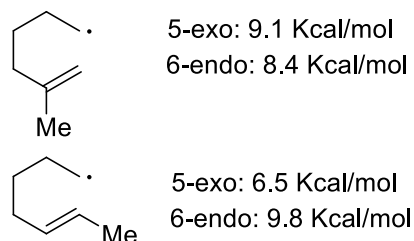

The high reactivity of radicals makes their intramolecular reaction on olefins a very fast and efficient reaction at room temperature. Radical methods are consequently often used in synthesis for cyclization reactions. If no reductant is present, the product is usually resulting from atom transfer. In presence of tributyltin hydride, the reduced product is obtained.

In accordance to the Baldwin rules, the 5-exo-trig reaction is stereoelectronically favored compared to the 6-endo-trig. For the unsubstituted system, this results in 3.7 Kcal/mol difference. The transition state is a chair for both the exo and endo cyclization. With increasing ring size, the exo process becomes less favorable. In addition to the stereoelectronic component, steric effects are important. In particular, if the 5 position is substituted, the endo process can become favorable.

Small rings: the fragmentation reaction is favored:

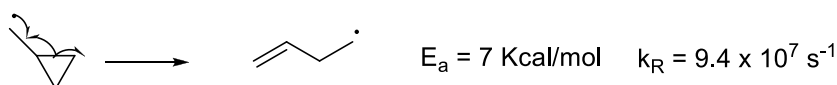

In the case of small rings, in particular cyclopropanes, the fragmentation reaction becomes favored. As the kinetics of radical cyclization and fragmentation reactions has been studied in details, these reactions can be used as **radical clocks** to estimate the rate of other processes, and also as an indication of the existence of radical intermediates.

Special radical generation methods:

- Oxidation of enolates and enamines

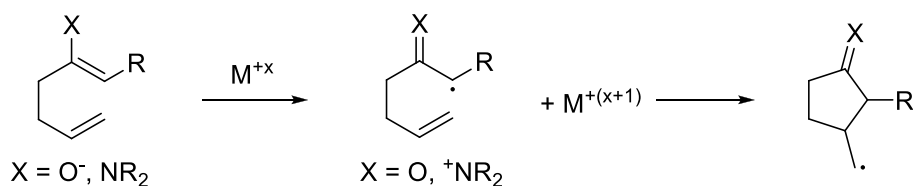

Another useful way to generate a radical for cyclization or other reactions is the one electron oxidation of electron-rich systems, for example enolates, enamines or phenols. Often used metals are Mn^{III}, Fe^{III} and Ce^{IV}.

- SmI₂: Reductive formation of radicals

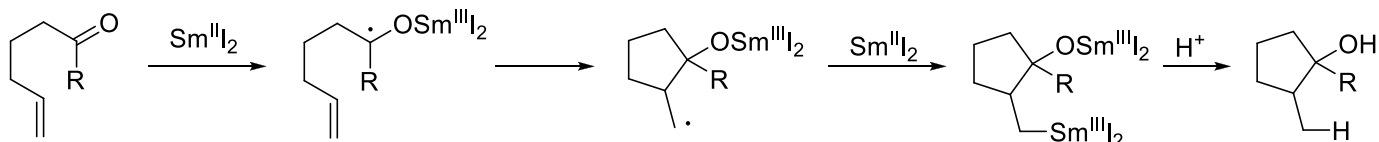

Samarium iodide is an exceptional reagent for the one electron reduction of carbonyls to form the corresponding ketyl radical anions. Cyclization gives then an alkyl radical, that can be further reduced to the anion using a second equivalent of samarium iodide. Finally, quenching the reaction with an acid gives the protonated product. Samarium iodide is a very special reagent, as it allows to combine the reactivity of radicals and anions in a single cascade of events.

5.3 Photochemistry in Organic Synthesis

Bibliography: Carey-Sundberg, A, Ch. 12, p. 1073-1155. B, Ch. 6.3.2, p. 544-552. Evans, Lectures 36, 36A.

A/ General considerations

sigma bonds

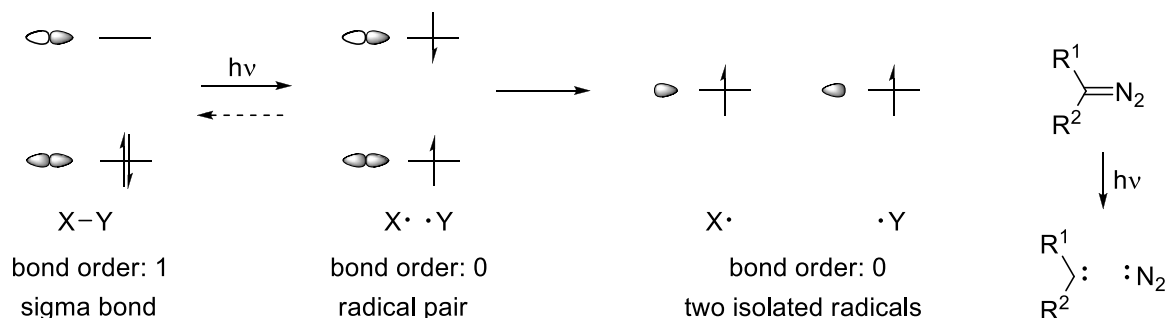

The simplest way to understand the effect of irradiation on organic molecules is the excitation from an electron from a binding (or lone pair) to a non-binding orbital. In the case of sigma bonds, it is a difficult process, as the energy gap is usually large. The reaction is limited to particularly weak bond (Br-Br, Sn-Sn,... see also chapter on radical reactions) and the special case of diazo compounds to form carbenes. Through the electron transfer, the bond is lost and a radical pair is formed, which can either recombine or completely dissociates to give two free radicals.

pi-bonds

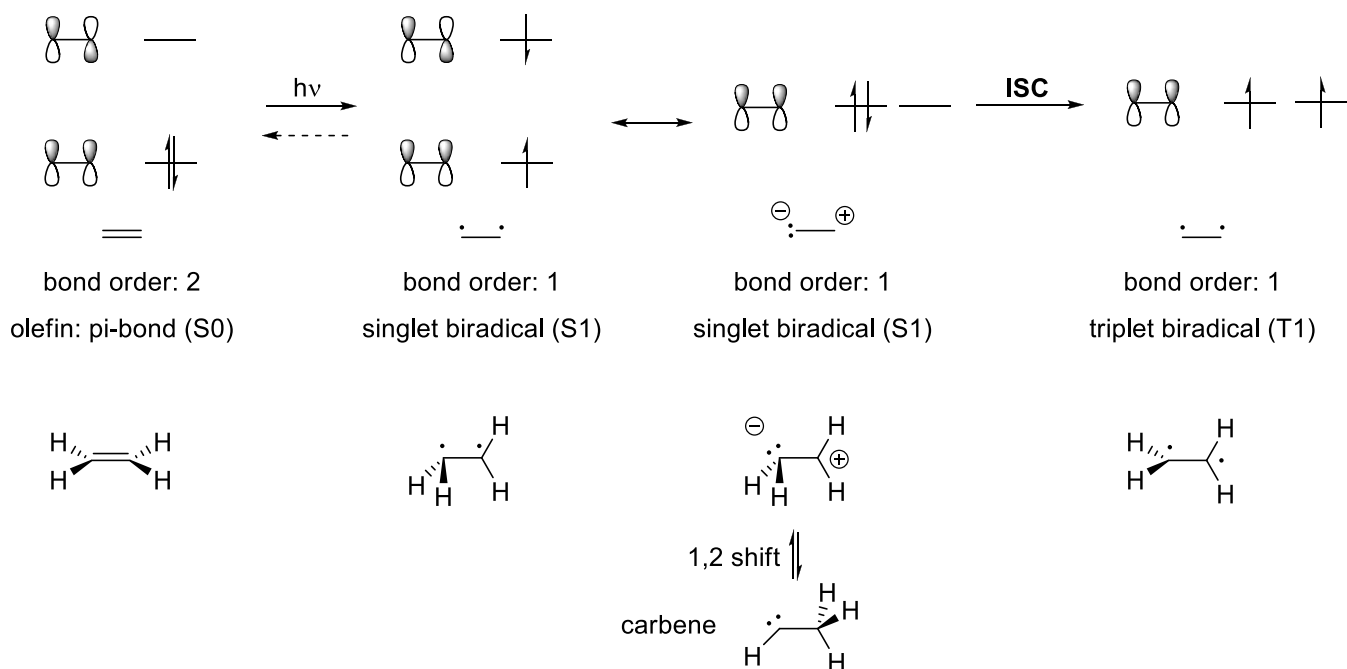

The reaction is easier with pi-bonds of olefins and carbonyls, as the energy gap is smaller. In this case, a biradical is obtained, first as a singlet system. Calculation have shown that the singlet state is not planar anymore and the most stable structure has a SP^3 geometry at one center and a SP^2 geometry at the second one. It is possible to consider consequently this intermediate as being zwitterionic. Furthermore, 1,2 H-shift is easy to give the corresponding carbene intermediate. Through inter system crossing (**ISC**), the triplet radical can be reached. The most stable structure is now two SP^2 centers, with a 90° angle between them, which is corresponding to a true biradical. The exact physical laws and kinetics behind these processes are complex and are seen in physical chemistry lectures.

B/ Isomerization of double bonds

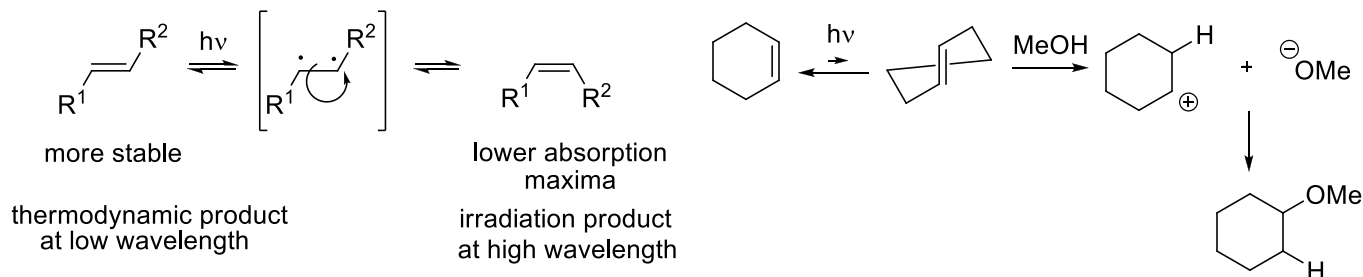

As a biradical is formed during the irradiation of olefins, rotation around the sigma bond becomes possible and isomerization can occur. The thermodynamically more stable product is the *trans* olefin, and it is obtained with low wavelength (high energy irradiation). Interestingly, *cis* olefins have lower absorption maxima for irradiation. By choosing a wavelength that is low enough to excite the *trans*-double bond, but not the *cis*, it becomes possible to obtain the *cis* as the major product! Irradiation allows also to reach high-energy intermediates that are unstable, such as *trans*-cyclohexene. The high reactivity of this olefin makes protonation easy, even with methanol, and the addition product can be obtained without the use of acid catalysts.

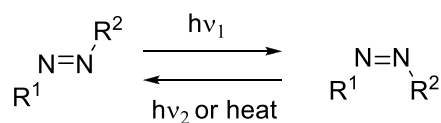

azobenzene: $R^1 = R^2 = \text{Ph}$

In the case of azo compounds, such as azobenzene, the geometry can be controlled by the used wavelength. Furthermore, the isomerization is easier and can proceed also under thermal conditions to give the more stable *trans* product. This reaction is highly useful for "molecular switches" in nanochemistry.

C/ Electrocyclization

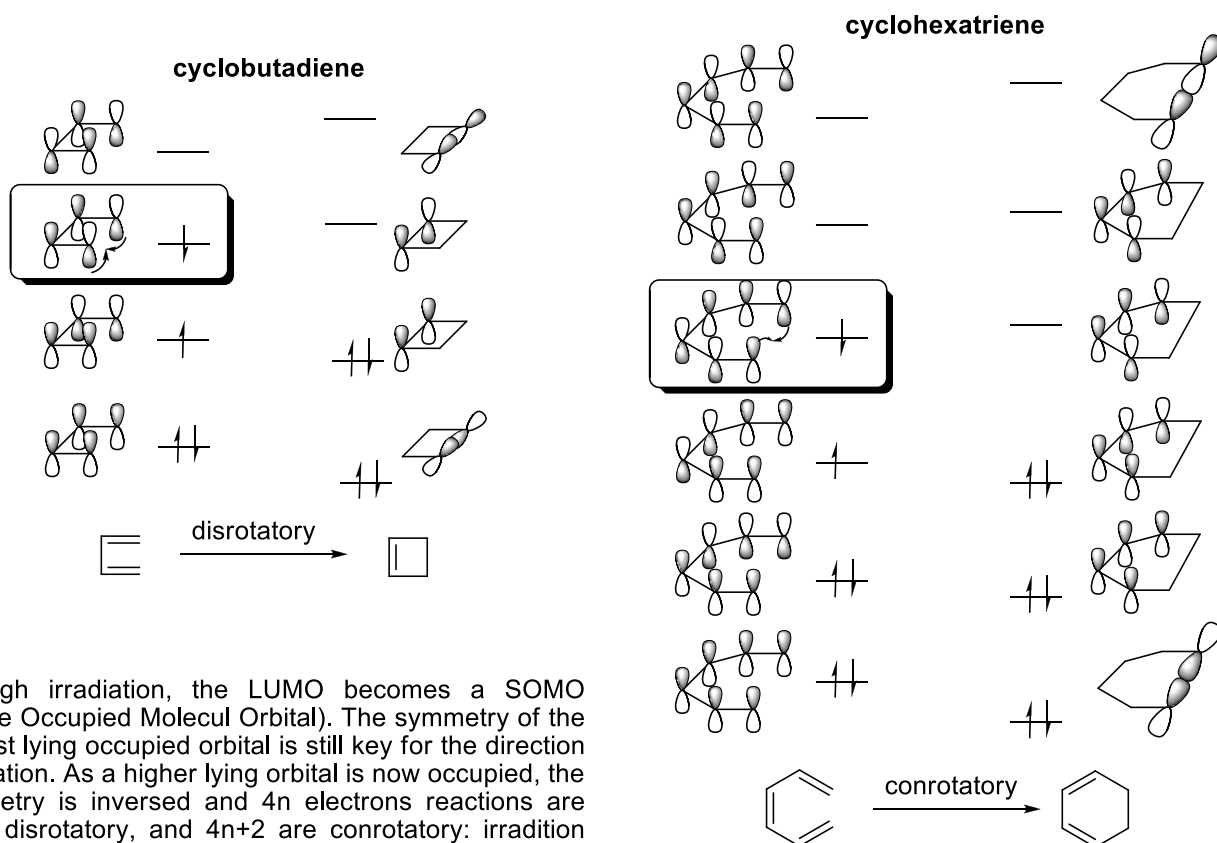

Through irradiation, the LUMO becomes a SOMO (Single Occupied Molecular Orbital). The symmetry of the highest lying occupied orbital is still key for the direction of rotation. As a higher lying orbital is now occupied, the symmetry is inverted and $4n$ electrons reactions are now disrotatory, and $4n+2$ are conrotatory: irradiation allows to inverse the selectivity observed for thermal reactions!

D/ Cycloaddition

D.1/ [2+2] cycloaddition

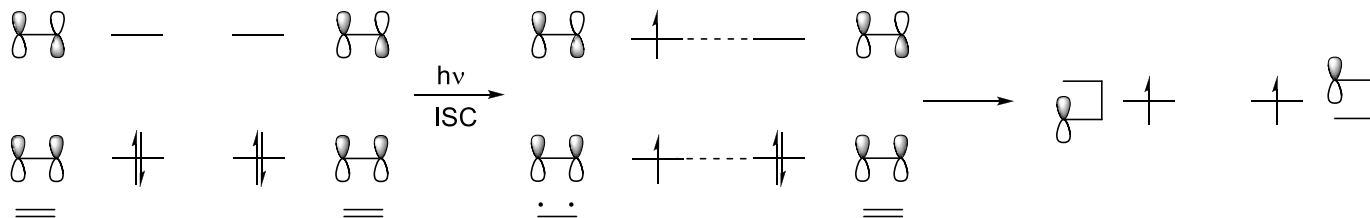

As for electrocyclic, the excitation of electrons into non-bonding orbitals changes the symmetry situation: the antarafacial [2+2] cycloaddition becomes now possible, after excitation and inter system crossing. The reaction is best described as proceeding via a biradicaloid intermediate, which then recombines to form the cyclobutane. The photo-induced [2+2] cycloaddition is one of the most important methods for the synthesis of cyclobutanes.

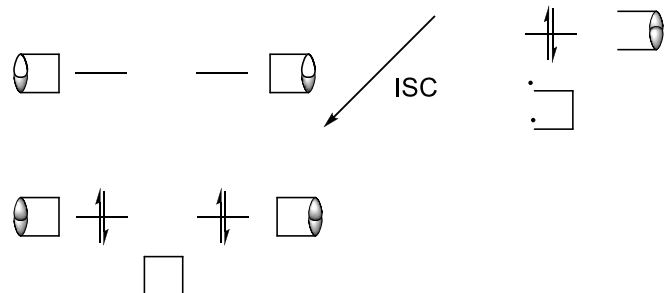

D.2/ Cycloaddition on benzene

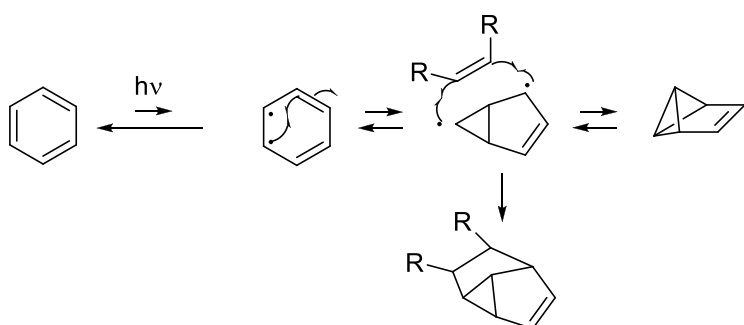

The excitation of benzene leads to structurally fascinating products via intramolecular addition of radicals on double bonds, followed by radical recombination. All these intermediates are very reactive and short-lived, but they can be intercepted by cycloaddition. The major product is usually the one resulting from a *meta* cycloaddition on the biradical intermediate. The reaction is concerted enough to conserve the stereochemical information of the double bond.

E/ Reactions involving carbonyls

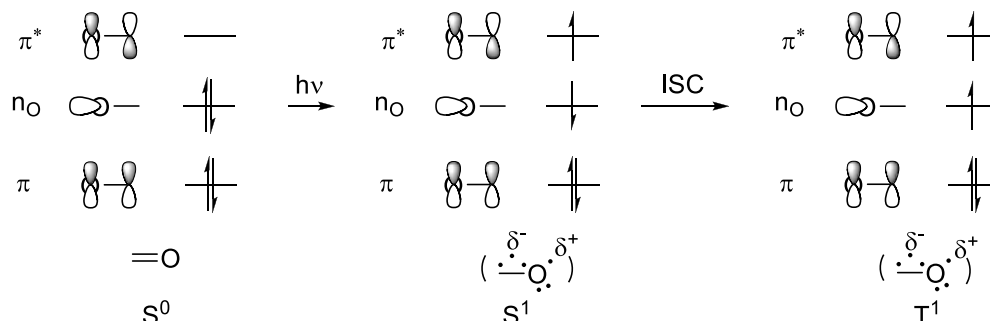

The photo-excitation of carbonyls is usually slightly different from olefins, as the easiest transition is usually from n to π^* , instead of π to π^* . The biradical obtained is now more difficult to describe with Lewis structures, but has definitively a strong radical character on oxygen. The situation becomes more complex when the carbonyl is conjugated to olefins or aromatic systems. In this case, the π to π^* transition can become favorable again.

E.1/ Norrish type I (alpha cleavage)

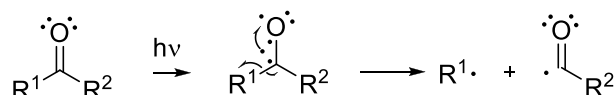

One of the most often follow up reactions of excited ketones is alpha cleavage (Norrish type I reaction)

E.2/ Norrish type II: H abstraction

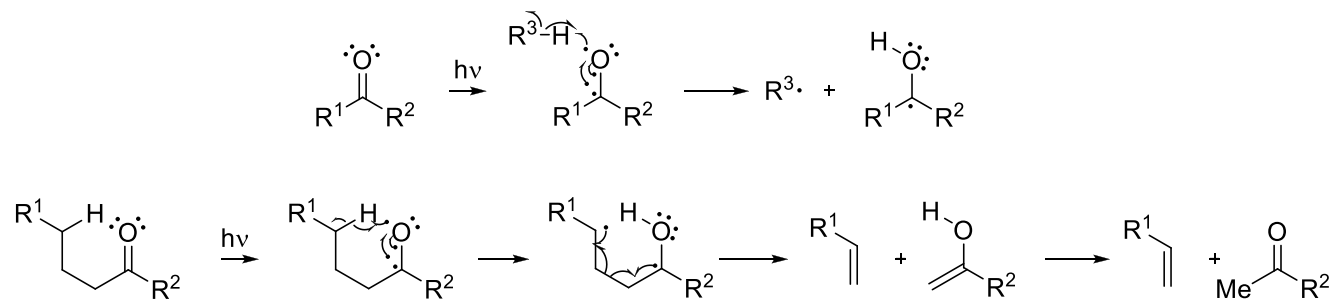

The second typical reaction of activated ketones is H abstraction by the radical on oxygen. The reaction can either proceed intermolecularly (often with the solvent) or intramolecularly via 1,5 abstraction. In this case, the formed radical fragments to the corresponding olefin and enol. The latter then tautomerizes to the ketone.

E.3/ [2+2] cycloaddition: Paterno-Büchi

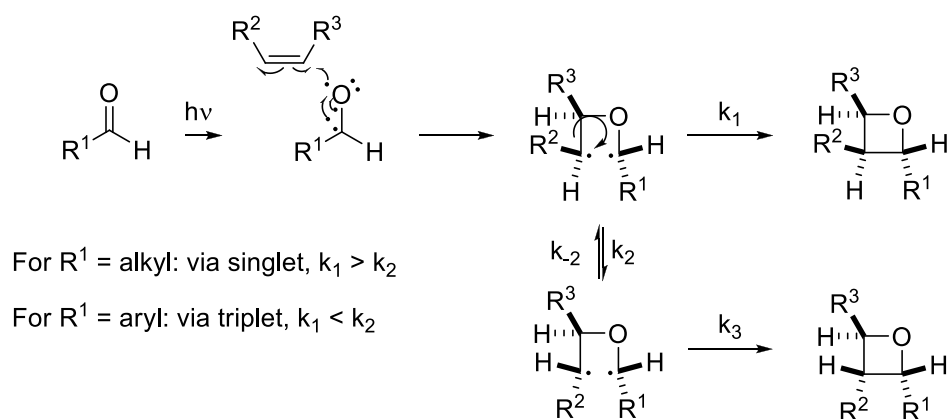

The Paterno-Büchi reaction is the [2+2] cycloaddition of olefins with ketones under irradiation. The reaction starts with activation of the ketone, followed by addition of the oxygen radical to the olefin. The regioselectivity of the reaction is controlled by the stability of the formed radical (R^2 better stabilizing group than R^3). In case of aliphatic aldehyde ($R^1 = \text{alkyl}$), the singlet state biradical reacts directly to form the product. There is no time for bond rotation and the stereoinformation of the double bond is kept in the product (*Z* double bonds give *cis* products, *E* double bonds give *trans* products). In the case of aromatic aldehydes ($R^1 = \text{aryl}$), the formed radical is more stable and ISC to the triplet can occur. The longer living biradical allows bond rotation, and the more thermodynamically stable product is obtained.

6. Umpolung and Unusual Reactivity

6.1 Principle of Umpolung and uses of dithianes

Bibliography: *Angew. Chem, Int. Ed.* **1965**, 1075.

Consonnant, Alternative

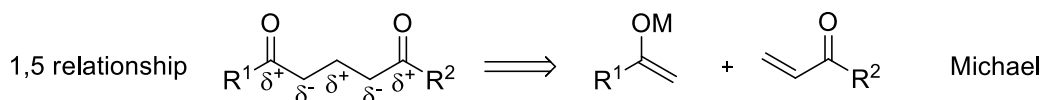
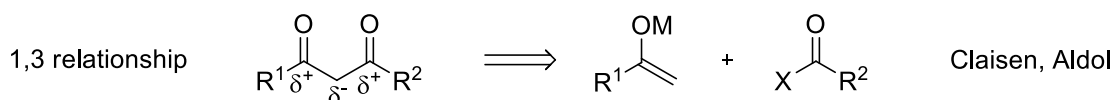

Dissonnant, not alternative

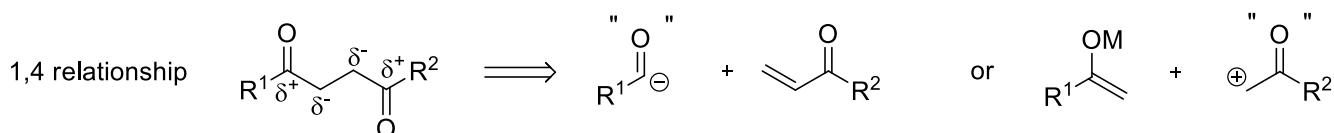
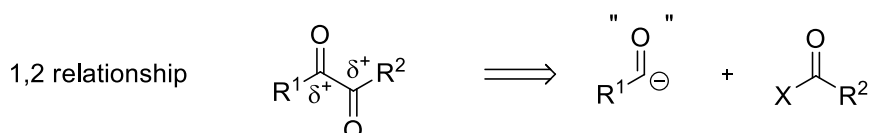

Umpolung is a German word and means "inversion of polarity". The word was first introduced when the retrosynthesis of polyketides was examined. Two cases can be distinguished: (1) The consonnant or alternative case, in which the functional groups are in an uneven distance. Easy disconnections are available, such as the Claisen/Aldol reactions or the Michael addition. (2) The dissonnant or not alternative case. The bond cannot be made using the classical reactivity of carbonyl compounds, and new reagents with reversed polarity/reactivity have to be created (**Umpolung**). In fact, the transformation of halogenides into organometallic compounds can also be considered as a Umpolung, as an electrophile becomes a nucleophile.

Use of dithianes for Umpolung

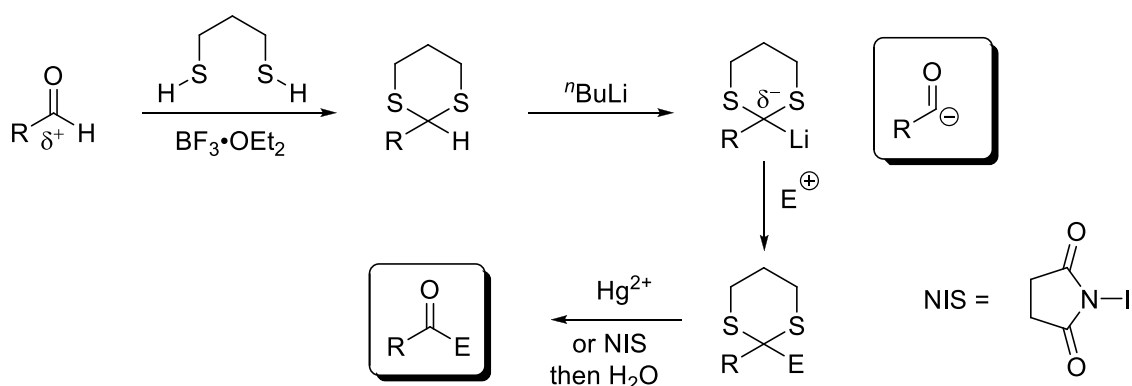

The development of acyl anion equivalents is particularly important in the chemistry of carbonyl compounds. **Dieter Seebach** (Harvard/ETHZ) introduced dithianes as reagents to achieve the Umpolung of carbonyls. The thioacetals are easily introduced on the aldehydes in the presence of a Lewis acid. The two sulfur atoms stabilize a negative charge and deprotonation with butyl lithium is now possible. The formed nucleophile adds to electrophiles. Finally deprotection in the presence of mercury salts or oxidants (NIS, $\text{PhI}(\text{OCOCF}_3)$) gives the carbonyl product with a dissonnant relationship.

special case: dithianes as linchpins

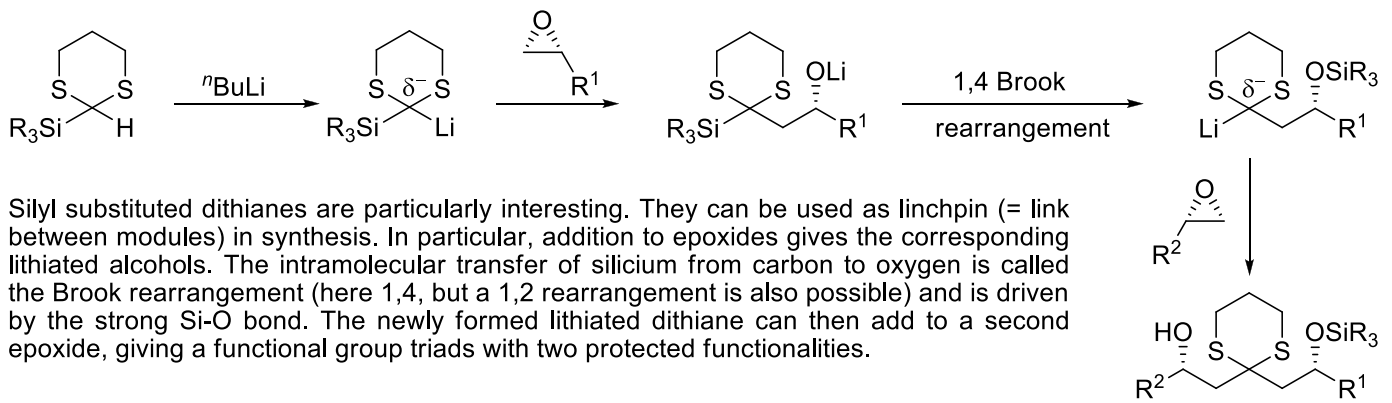

Silyl substituted dithianes are particularly interesting. They can be used as linchpin (= link between modules) in synthesis. In particular, addition to epoxides gives the corresponding lithiated alcohols. The intramolecular transfer of silicon from carbon to oxygen is called the Brook rearrangement (here 1,4, but a 1,2 rearrangement is also possible) and is driven by the strong Si-O bond. The newly formed lithiated dithiane can then add to a second epoxide, giving a functional group triads with two protected functionalities.

6.2 Umpolung using nitro compounds

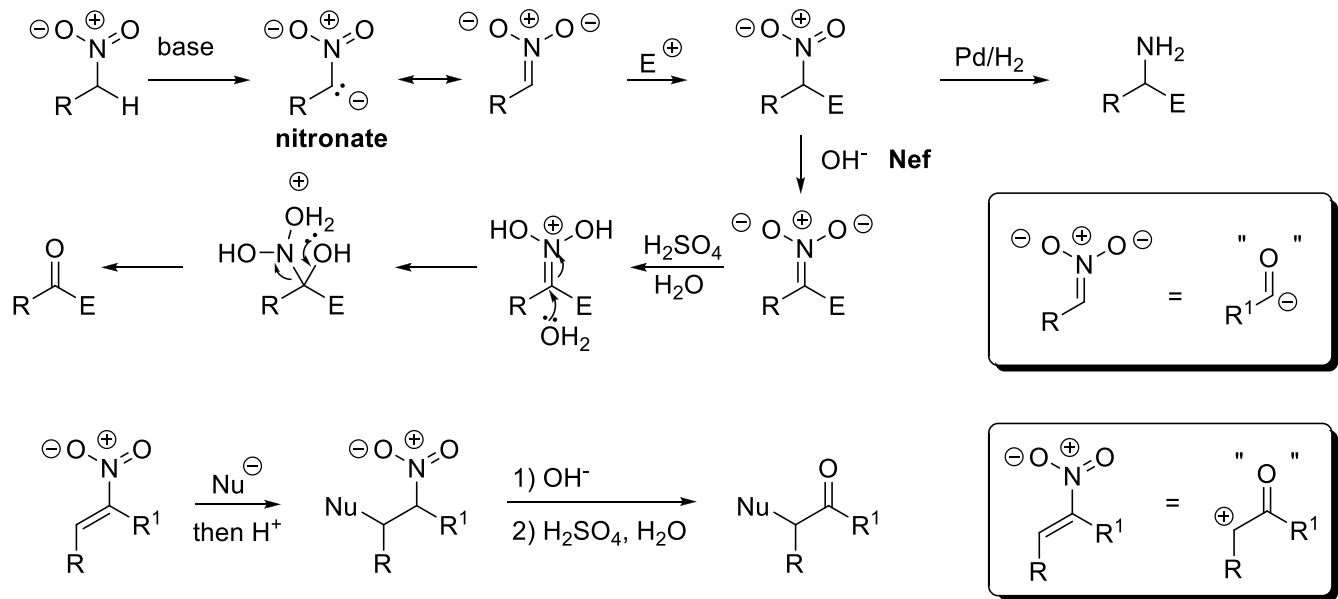

The chemistry of nitro compounds is very rich (they have been called the chemical chameleon by Dieter Seebach). The nitro group is very electron-withdrawing, and deprotonation to form the nitronate anion is easy. Reaction with an electrophile can then occur (often an aldehyde, it is then the **Henry reaction**, the nitro equivalent of the aldol reaction). The nitro product can be reduced to the amine or hydrolyzed to the ketone, first under basic and then under acidic conditions (**Nef reaction**). In this case, nitronates are acyl anion equivalents. The use of nitro olefins is then an equivalent of the Umpolung of enolate and allows the synthesis of carbonyl compounds with a nucleophile in alpha position.

6.3 Catalytic Umpolung

A/ Benzoin condensation

cyanide as catalyst

The condensation of two molecules of aldehydes to form the corresponding alpha-hydroxy ketone is an example of catalytic Umpolung. The reaction begins with addition of cyanide to the aldehyde, followed by proton transfer. The formation of the carbanion is helped by the strong electron-withdrawing effect of cyanide. The obtained acyl anion equivalent can then add to a second molecule of aldehyde. After proton transfer and release of cyanide, the hydroxy ketone is formed.

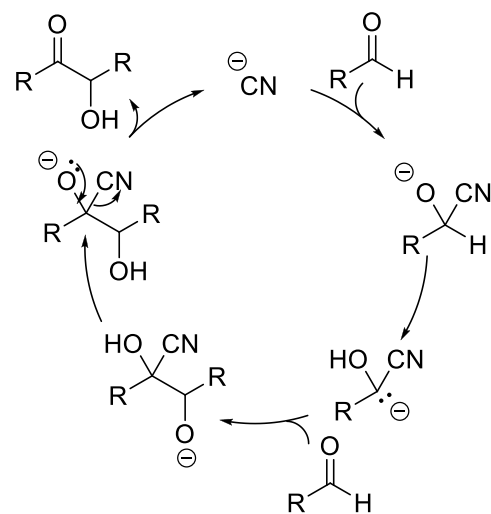

carbenes as catalysts

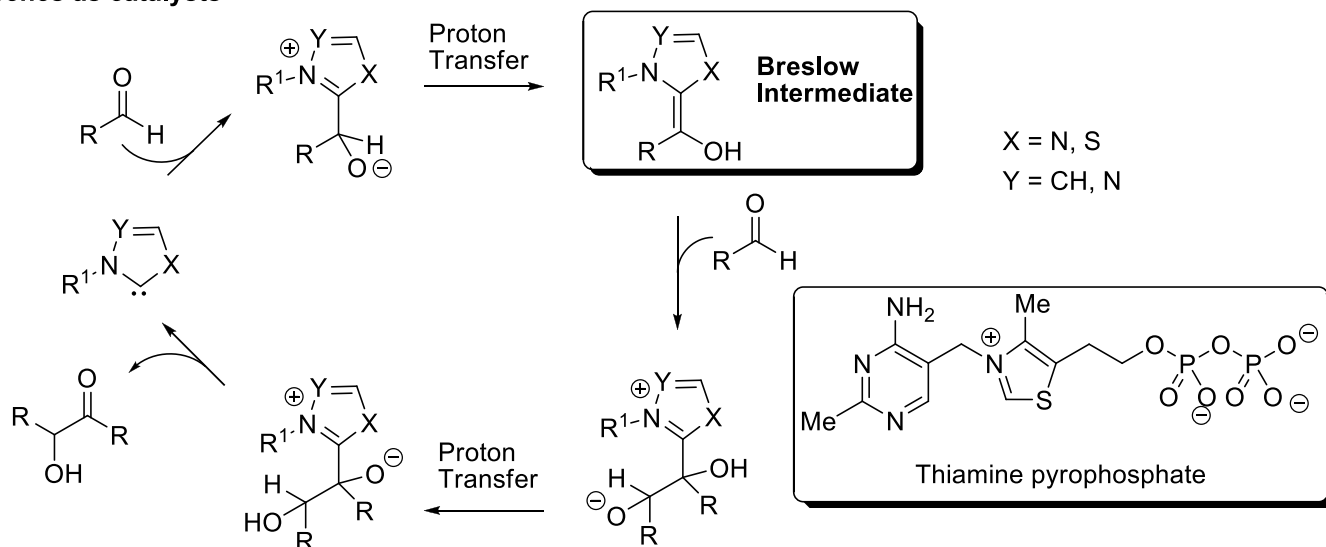

A second important class of catalysts for the benzoin condensation is the N-heterocyclic carbenes. Particularly good are thiazolium and triazolium derivatives. The mechanism is similar to the case of cyanides. The key intermediate for Umpolung was first proposed by Breslow. Nature is also using nucleophilic carbene catalysis with the co-factor thiamine pyrophosphate, which is used in enzymes such as pyruvate reductase.

B/ Stetter Reaction

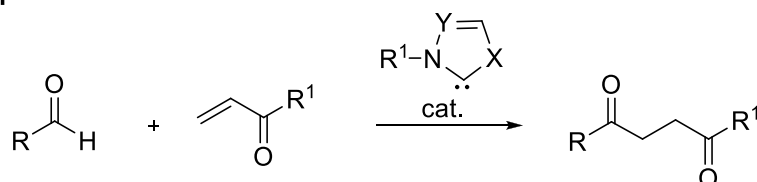

In the Stetter reaction, one of the aldehyde is replaced by a conjugated system and a conjugate addition occurs with the Breslow intermediate formed from the aldehyde. The dissonant 1,4 dicarbonyl product is obtained.

C/ Conjugate Umpolung

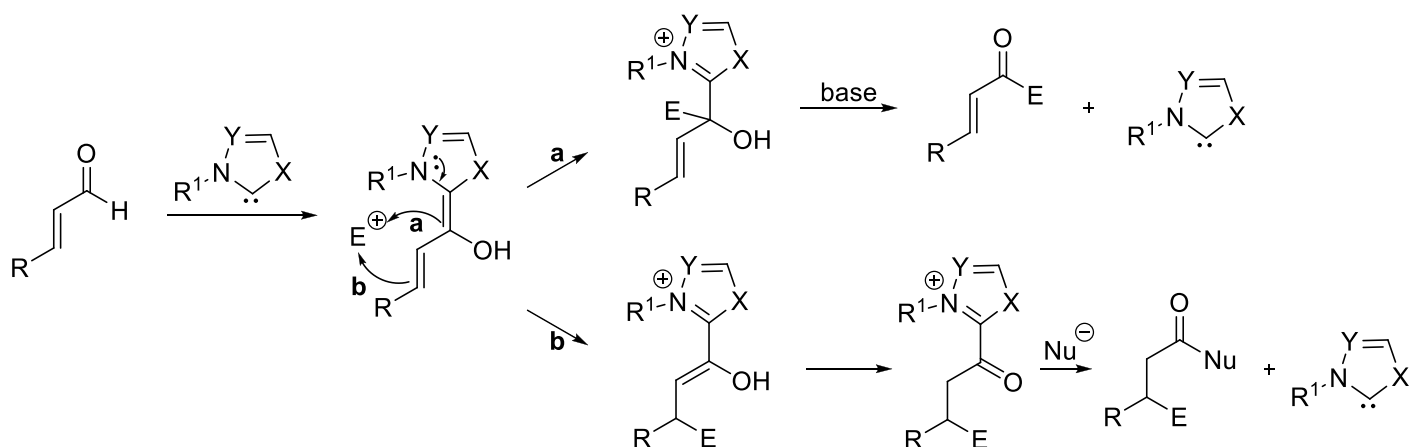

In the case of conjugate aldehydes, a dienamine is obtained as Breslow intermediate. Attack at the usual position (a) leads to the expected acylation product. The gamma position is also nucleophilic (vinylogous principle) and addition of the electrophile there gives an enol product, which tautomerizes to the carbonyl (b). To allow catalytic turnover, a nucleophile (often an alcohol) is required to free the catalyst. The reaction sequence is then equivalent to the conjugate addition of an electrophile to a conjugated ester. The structure of the catalyst is important for the selectivity between a and b. Sterically hindered catalysts tend to favor reactions via pathway b.

7. Transition Metals in Organic Chemistry

Bibliography: Carey Sundberg B, Ch. 7-8, p. 619-782. Brückner, Ch. 16, p. 691-736.

The use of transition-metal catalysis was a game changer in synthetic organic chemistry. This was recognized by the two recent nobel prizes for Metathesis (2005, Chauvin, Grubbs and Schrock) and Cross Coupling using Pd catalysts (2010, Heck, Suzuki and Negishi). The elemental steps of metal-catalysis are discussed in detail in the inorganic chemistry lectures. This lecture focuses on relevant aspects and implications for organic synthesis.

7.1 Cross-Coupling

Bibliography: Diederich, F.; De Meijere, A. *Metal-Catalyzed Cross-Coupling Reactions: 2 Bde*, Wiley-VCH, 2004.

7.1.1 Preparation of coupling partners

Bibliography: Schlosser M., *Organometallics in Synthesis, A Manual*, 2nd Edition, Wiley, 2002.

A/ Electrophiles (I, Br, OTf, Cl, OTs,...)

A.1/ Substitution

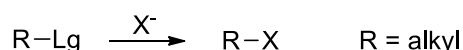

A simple nucleophilic substitution gives access to halide electrophiles. This not the most direct method, as the leaving group itself has to be introduced first (for example via an alcohol activation). Nevertheless it is still useful when a less reactive electrophile can be transformed into a more reactive one (especially iodide).

A.2/ Addition

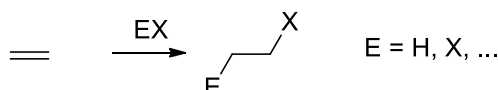

Electrophilic addition reactions to olefins are an efficient way to generate the required organo halides. Most of these reactions were introduced in the bachelor lectures. One major issue is to control the regio- and stereo-chemistry of the addition step.

A.3/ Electrophilic aromatic substitution

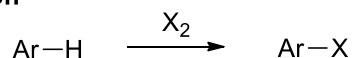

The electrophilic aromatic substitution (often with reagents like I₂, Br₂, Cl₂, NCS, NBS, NIS) is a very important method for the introduction of halogens onto aromatic rings. Consequently, many of these substrates are commercially available.

A.4/ Alcohol activation

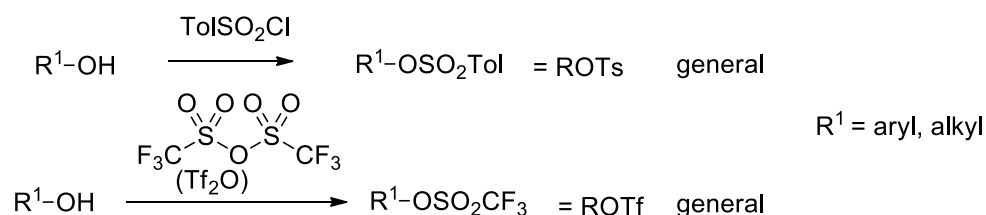

Appel Conditions

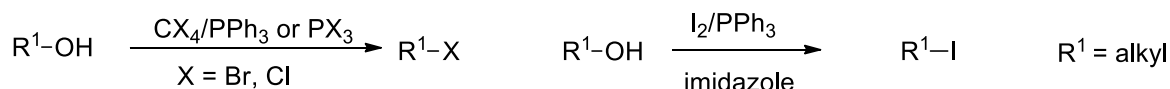

The activation of hydroxyl groups is another method to generate electrophiles. These methods were extensively discussed in bachelor lectures. The tosylation and trifluoromethylsulfonation of alcohols is a general method, which can be applied both to aliphatic alcohols as well as phenols. The direct transformation of alcohols into halogens using **Appel conditions** is limited to aliphatic alcohols.

A.5/ Activation of ketone

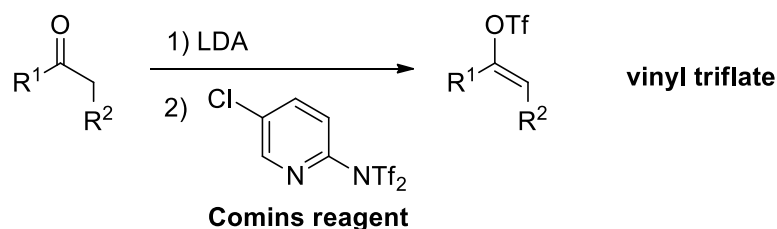

The transformation of ketones into vinyl triflates is one of the most useful reactions for the preparation of vinyl electrophiles. Although the reaction also works with classical reagents, such as triflic anhydride, the best reagent is the pyridine-derived bistriflimide reagent developed by **Comins**.

A.6/ Reaction of organometallic reagents

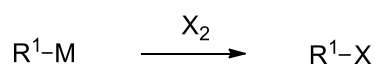

The reaction of organometallic compounds with halogenation reagents like I_2 , Br_2 , Cl_2 , NCS, NBS, NIS is another important synthetic access to halides. The reaction is especially often used with organolithium, organozinc, organotin and organoboron reagents.

B.1/ Oxidative insertion of main group metals

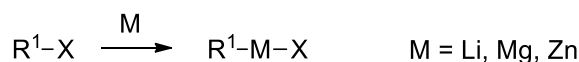

The oxidative insertion of metals into C-X bonds is one of the most straightforward methods for the preparation of organometallic reagents. Although very exothermic, these reactions have a strong kinetic barrier. Consequently, heating is often required at the beginning of the reaction. Additionally, many functional groups are not compatible with these conditions. Several methods have been developed to accelerate the oxidation step: activation of the metal surface with iodine or dibromoethane; preparation of highly reactive Riecke metals from the reduction of metals salts, or ultrasonic activation.

B.2/ Metal-halogen exchange

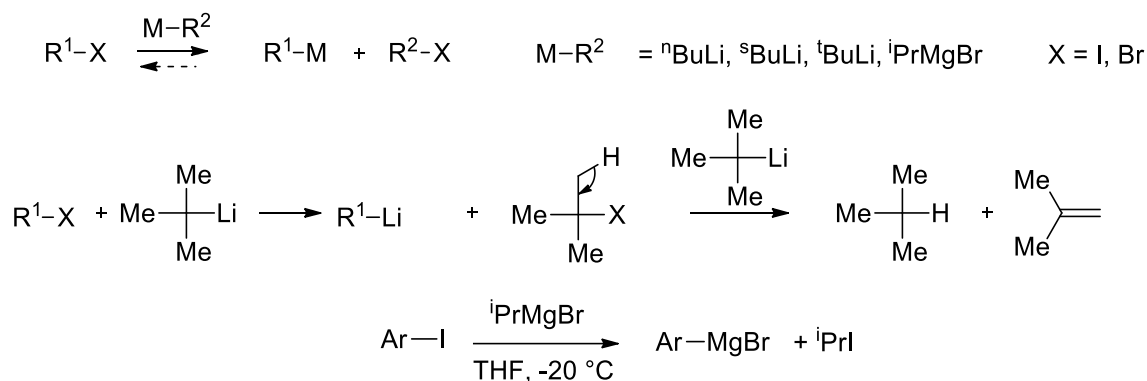

In contrast to oxidative insertion, the metal halogen exchange is a fast process with lithium. A disadvantage of this approach is the generation of a new C-X bond. The reaction works well if the formed organometallic reagent is more stable. This is especially true when using an *alkyl* lithium reagent with a *aryl* bromide or iodide. The use of *tert*-butyl lithium is a special case, as the *tert*-butyl iodide/bromide reacts further with *tert*-butyl lithium to form *iso*-butane and isoprene. In this case, **two** equivalents of organolithium are required, but the reaction is truly irreversible. An important advance in the synthesis of Grignard reagents was realized by the use of *i*PrMgBr. This allows magnesium-halogen exchange on aryl iodides at $-20^\circ C$ (**Paul Knochel, Angew. Chem., Int. Ed. 2003, 4302**), allowing the generation of sensitive Grignard reagents containing reactive groups, such as esters or nitriles.

Transition-metal catalyzed "metal halogen exchange"

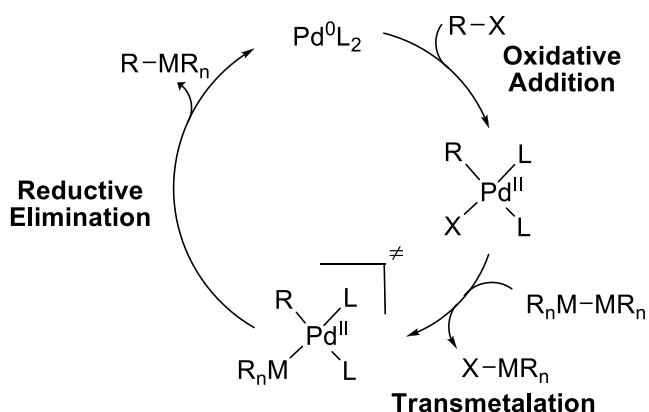
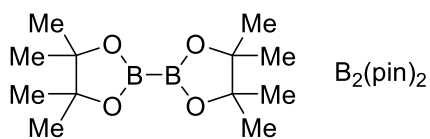
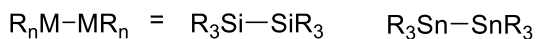
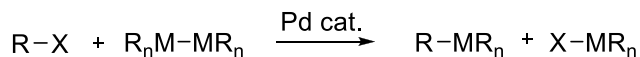

The direct metal halogen exchange with less reactive half metal, like B, Sn and Si is not possible. In this case, metal catalyzed reductive coupling with dimetal reagents is the method of choice. The advantage of this method is that no highly reactive organometallic intermediate is formed. The reaction follows the classical steps of a cross-coupling reaction, except that a half-metal is transferred in the transmetalation step and a half metal-carbon bond is formed in the reductive elimination step.

B.3/ Metalation ("deprotonation")

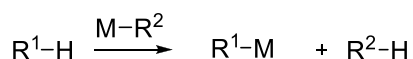

directed metalation

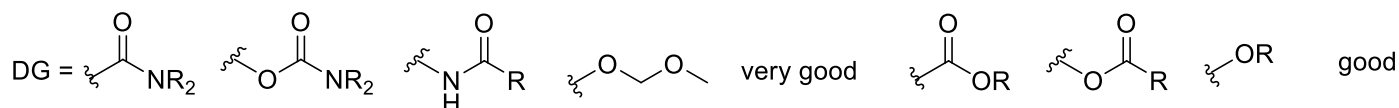
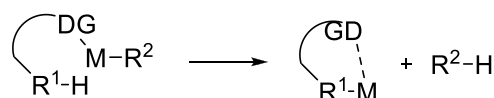

Important cases:

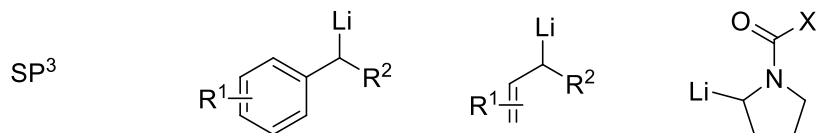
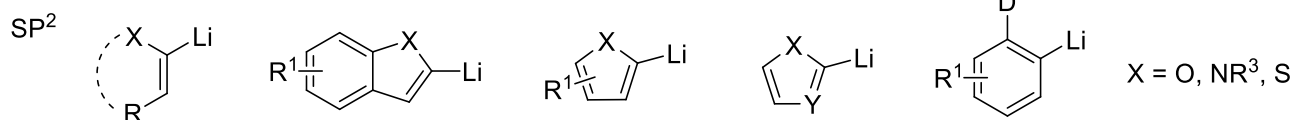

The direct metalation of C-H bonds is an important method, as it does not require pre-functionalization of the substrates. The reaction has been especially successful for lithiation, although other metals are currently under investigation. As there are many C-H bonds in an organic molecules, selectivity is possible only if the targeted C-H bond is more acidic or if a directing group can bind the metal to make the reaction pseudo intra-molecular. The most important substrates are heteroatom substituted olefins, heterocycles, benzene rings with directing groups for SP² C-H bonds, and benzylic, allylic or alpha to heteroatoms C-H for SP³ C-H bonds. Generally, the metalation is easier on SP² C-H bonds, as these bonds are more acidic.

B.4/ Transmetalation/ Substitution

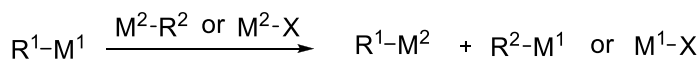

Several of the methods described up to now works especially well for very reactive metals, such as lithium or Grignard. The obtained organometallic reagents are very reactive and sensitive, which makes their use difficult, especially when other functional groups are present. They are not well suited for catalysis, as the uncatalyzed reactions are usually already fast. Consequently, the transmetalation to other, less reactive organometallic reagents is an important method. The transmetalation or substitution can occur either under formation of another organometallic reagent or via the formation of a salt. Apart from stoichiometric reactions, it is an important key step in many catalytic cycles (see section 7.1.2)

Synthetic important cases:

Reaction of organolithium and Grignard reagents

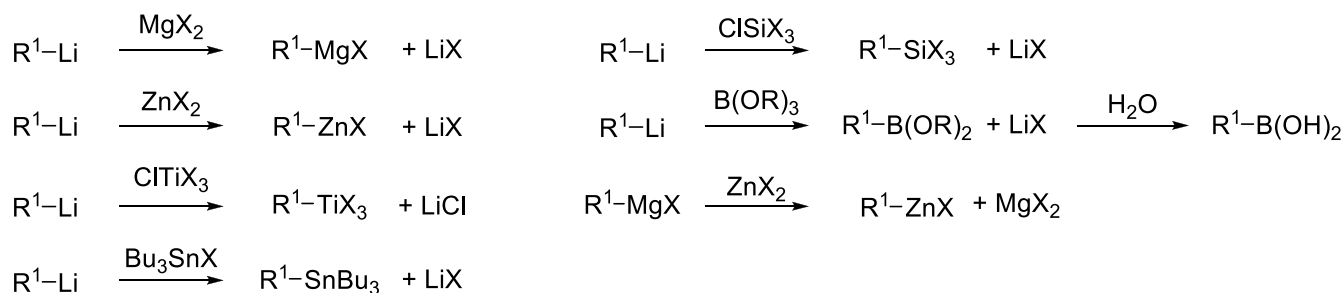

The most often used starting materials for transmetalation reactions are organolithium and Grignard reagents. The transmetalation to less reactive organozinc works well with simple zinc salts. The use of chloro tin, titanium and silicium reagents allow to access the corresponding organometallic reagents, which are also important in cross-coupling reactions. Finally, the probably most important case is the synthesis of boronic esters, which can then be hydrolyzed to the corresponding boronic acids for Suzuki coupling.

Synthesis of Cu-Based reagents

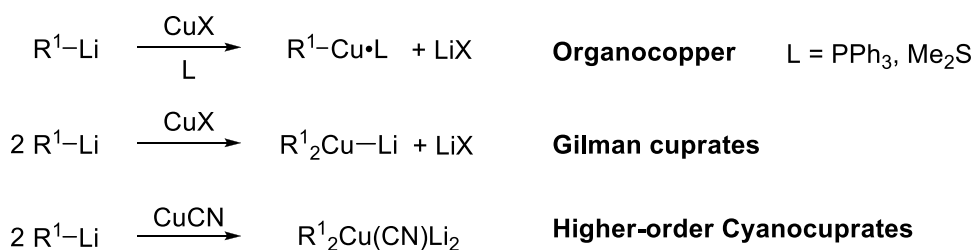

From Grignard reagent: $\text{R}^1\text{Cu}\cdot\text{MgX}_2$, R^1_2CuMgX , $\text{R}^1_2\text{Cu(CN)Mg}$

Transmetalation also from Sn, Al, Zn reagents

Organocuprates are very important in organic synthesis, as they have a complete different reactivity as organolithium or Grignard reagents. They are much softer, less basic and prefer to react in conjugate addition or substitution reactions. Often, a catalytic amount of copper is enough, but the stoichiometric reagents are also very useful. The organocopper reagents are obtained from a 1:1 mixture of organolithium and Cu(I)X . They are often unstable and explosive in the absence of stabilizing ligand, such as phosphines or sulfides. They are usually less reactive. The reagents obtained by mixing one equivalent of copper salt with two equivalents of organolithium are called Gilman cuprates and are very often used for conjugate addition in organic chemistry. In the special case of CuCN , a higher order cuprate is obtained, which is even more nucleophilic. The different copper reagents can also be prepared from the corresponding Grignards. In this case, the reactivity is slightly different. Finally, transmetalation from tin, aluminium or zinc is also possible.

B.5/ Carbo- and hydro metalation of olefins and alkynes

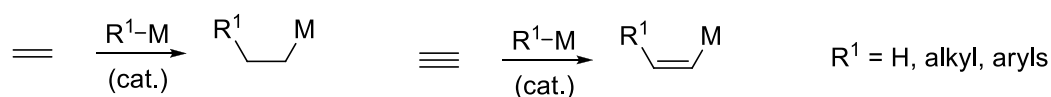

The carbo- or hydro- metalation of olefins and alkynes is an atom economical method to access alkyl and vinyl organometallic reagents. The reaction proceeds directly from bulk reagents such as olefins and alkynes without the generation of waste. The reaction can be fast with borane, zirconium hydride or aluminium hydride reagents, but requires a catalyst in the case of silane or the carbometalation reactions. The catalytic reactions will be seen in section 7.3.

Synthetic important reactions:

Hydroboration: diastereoselective synthesis of vinyl organometallic reagents and electrophiles

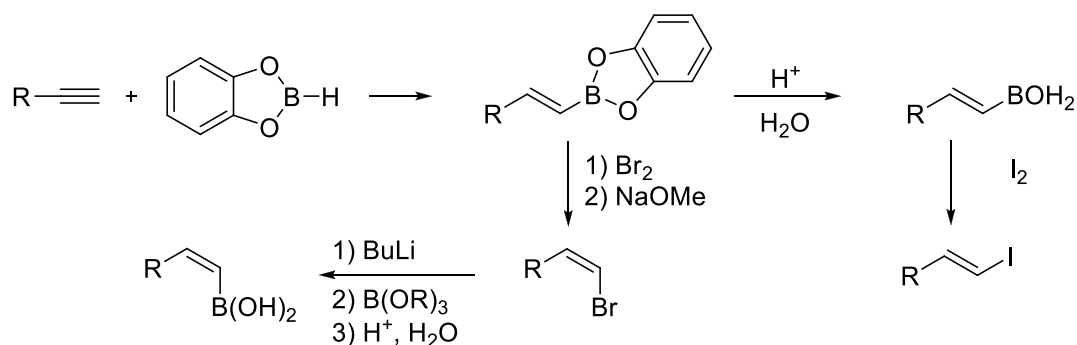

The hydroboration of alkenes is an important reaction for the synthesis of alkyl boranes, which has already been seen in details in other lectures. The hydroboration of alkynes gives access to *E* alkene boranes. Hydrolysis of the borate ester gives the *E* vinyl boronic acid. Oxidation with iodine gives then the *E* vinyl iodide. On the other hand, treatment of the boronic ester with bromine followed by sodium methoxide gives the *Z* vinyl bromide. Lithium halogen exchange followed by transmetalation to boron and hydrolysis finally gives the *Z* vinyl boronic acids. Consequently, all four building blocks required for the synthesis of the geometric isomers of dienes (*E,E*; *Z,E*; *E,Z* and *Z,Z*) can be accessed.

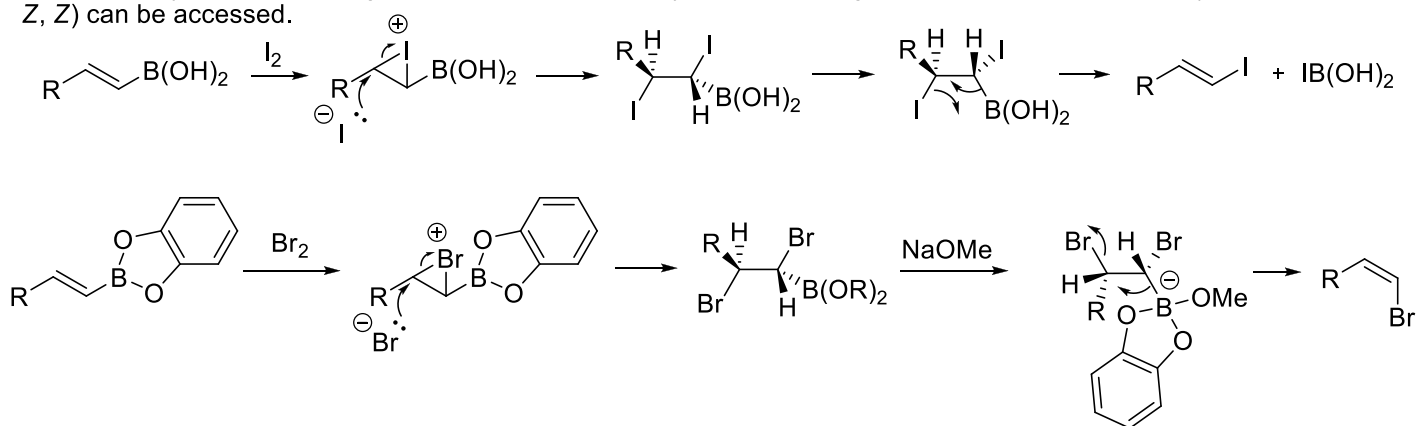

In the case of the oxidation of vinyl-boronic acids with iodine in the absence of a base, a possible mechanism is diiodination of the double bond, followed by *syn* elimination. If nucleophilic base is present, activation of the boronic ester is possible and an *anti* elimination takes place to give the *cis* vinyl bromide. In this case, better selectivities are obtained for bromine.

Hydrozirconation

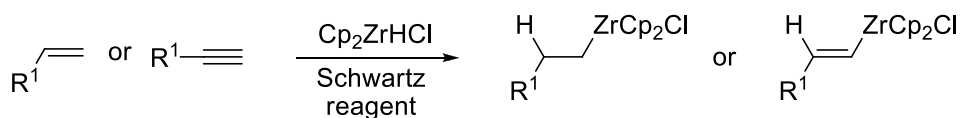

The zirconocene reagent developed by Schwartz is one of the most efficient reagent for the regioselective hydrometalation of olefins and alkynes. An advantage of the formed organozircon reagent is its easy transmetalation to other metals, especially zinc and copper.

7.1.2 Classical Cross Couplings

General Scheme

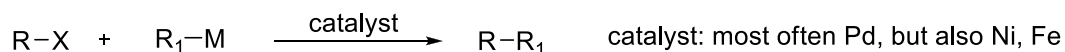

The metal catalyzed cross-coupling of carbon electrophiles with nucleophilic organometallic reagents is the most classical cross coupling reaction. Pd is by far the most often used catalyst, but other cheaper metals are currently also intensively investigated.

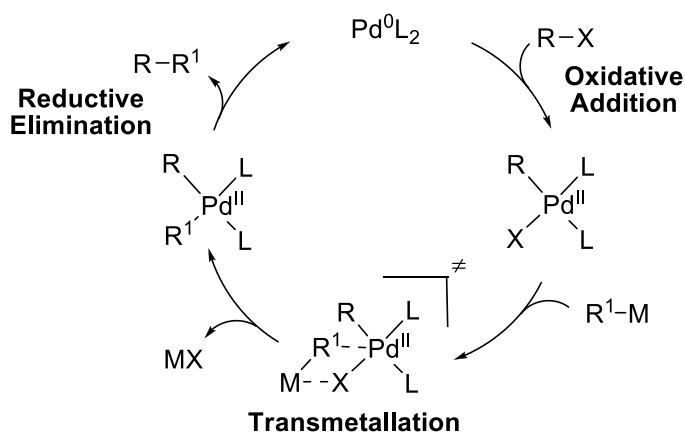

M = SiX₃: **Hiyama**
 M = BX₂: **Suzuki**
 M = SnR₃: **Stille**
 M = ZnX: **Negishi**
 M = MgX: **Kumada**

Scope:

R and R¹ groups

easy: R, R¹ = aryl, alkenyl, alkynyl

difficult: R¹ = alkyl

very difficult R = alkyl (topic of current research)

X groups

easy: I, Br, OTf

difficult but more interesting: Cl, OTs, H

Comparison of organometallic reagents

Reactivity: SiX₃ < BX₂ < SnR₃ < ZnX < MgX

Stability: SiX₃ > BX₂ > SnR₃ > ZnX > MgX

In the cross coupling methods, a metal catalyst promotes the reaction between an electrophilic and a nucleophilic partner. The direct reaction between the two partners either does not take place at all, or is very slow and ask for harsh conditions. Most metal-catalyzed cross couplings follow the same general scheme: oxidative addition of a low valent metal catalyst (especially Pd(0)) to the electrophile, followed by transmetalation with an organometallic nucleophile. Reductive elimination from the formed dialkyl complex then gives the coupling product and regenerates the catalyst. The exact mechanism of these key steps will be seen in lectures in inorganic chemistry.

Nucleophilic activation for transmetalation:



The less reactive organometallic reagents need to be activated by a nucleophile prior to transmetalation. This is in particular important for the Suzuki and the Hiyama coupling.

Important side reactions

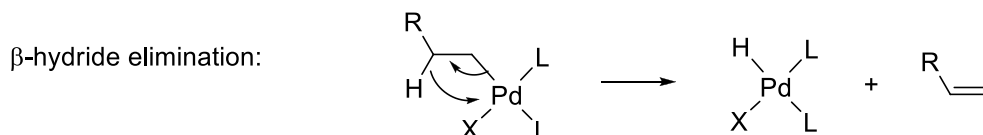
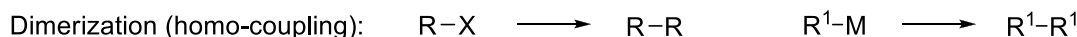

Beside low conversion, side reactions can lower the yield of cross-coupling reactions. In particular, dimerization (homo-coupling) and protodematalation can occur in all cross-coupling reactions. The cross-coupling of alkyl derivatives is particularly difficult, as a fast beta-hydride elimination can occur.

Synthetic important reactions:

Important recently introduced ligands for faster oxidative addition

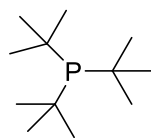

Tri-tert-butyl phosphine

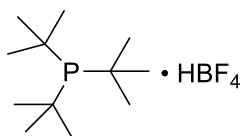

Fu, MIT

Steric bulk to promote mono-coordination

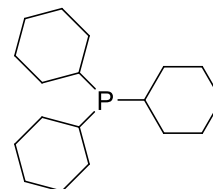

Tricyclohexylphosphine

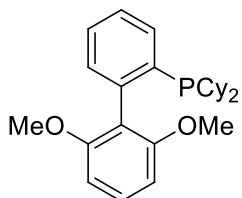

SPhos

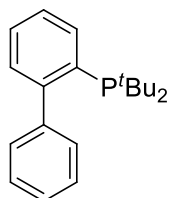

JohnPhos

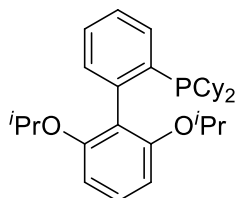

RuPhos

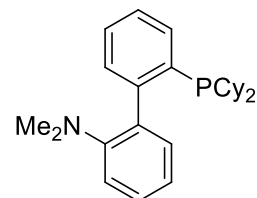

DavePhos

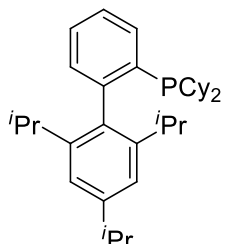

XPhos

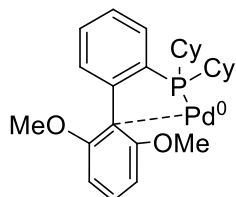

Biarylphosphine

Buchwald, MIT

Pd-Aryl interaction to promote mono-coordination

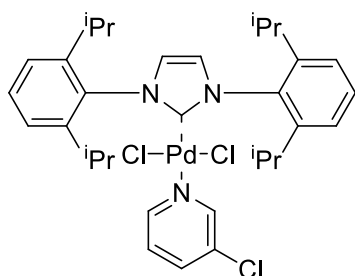

N-Heterocyclic Carbenes (NHC)

more electron-rich than phosphines

here: commercially available PEPPSI ligand (Aldrich)

The originally developed cross-coupling reactions used simple phosphine ligands, such as triphenyl phosphine. These reactions worked best for aryl bromides and iodides, which are more expensive than other electrophiles. An important field of modern research is the discovery of conditions for the cross-coupling of cheaper aryl chlorides. The oxidative addition is very slow for these substrates, but it can be accelerated by using electron-rich, sterically encumbered phosphines. Such phosphines form a mono-coordinated palladium (0) complex, which is able to add to aryl chloride. **Greg Fu** in MIT introduced tri(*tert*-butyl)phosphine as ligand. Tri(*tert*-butyl)phosphine is very air sensitive, but the corresponding stable protonated form with tetrafluoroboric acid can be used to generate the ligand *in situ*. Another important sterically hindered phosphine is tricyclohexylphosphine. A second class of ligand has been introduced by **Stephen L. Buchwald** at MIT: biaryl phosphines can stabilize mono-ligated Pd(0), and this system is also very efficient for oxidative addition on aryl chloride (*Acc. Chem. Res.* **2008**, *41*, 1461.). A library of these ligands has now been introduced. N-heterocyclic carbenes are another important class of electron-rich, sterically hindered ligands. They have been shown to be stronger sigma donor and weaker pi acceptors than phosphines (see inorganic chemistry).

Use of organotrifluoroborates

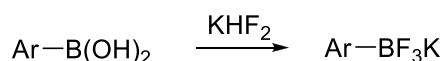

Organotrifluoroborates, introduced by **Gary Molander** (*Angew. Chem., Int. Ed.* **2009**, *48*, 9240) have several advantages: there are more stable than boronic acids, easy to store and less protodeboration side reaction is observed with these reagents.

Microwave and water

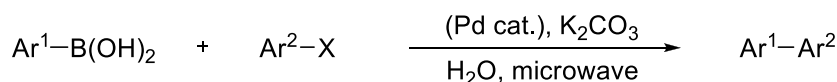

The search for "greener" reaction conditions is another important field of research. The least toxic solvent is obviously water and especially efficient Suzuki coupling in water under microwave irradiation have been developed. In some cases, the Pd catalyst can be omitted, as the ppb impurities of Pd in the carbonate base are enough to catalyze the reaction.

Alkyl Suzuki

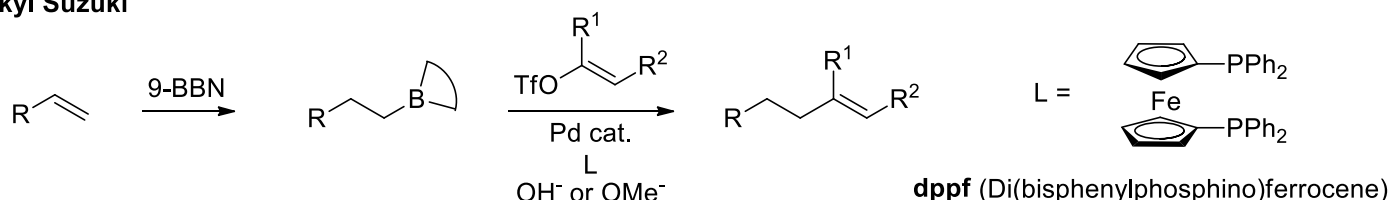

Because of the beta-hydride elimination, the development of alkyl Suzuki reactions was difficult. One of the best systems use the product obtained by the hydroboration of olefin with 9-BBN (nonabicycloborane) together with a vinyl electrophile. Again, a nucleophilic base is required for activation of the borane. The best ligands are bidentate ferrocenes, as the second coordination makes beta-hydride elimination more difficult. The use of alkyl halides, however, is still extremely difficult with Pd catalysts.

Dienes Synthesis

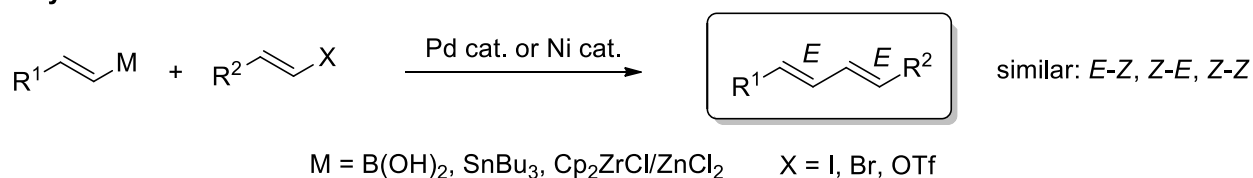

Dienes are important building blocks in organic synthesis, and cross-coupling is one of the most efficient methods for their stereoselective synthesis. The necessary partners can be accessed stereoselectively (see section 7.1.1). Beside the Suzuki reaction, the Stille reaction is often used with complex molecules, as it allows the use of milder reaction conditions. The Negishi coupling is also very efficient, both with palladium and nickel catalysts. The organozinc intermediates can be obtained in situ via transmetalation from the hydrozirconium reagents, which are easily synthesized from the corresponding acetylenes.

Alpha-arylation of carbonyls

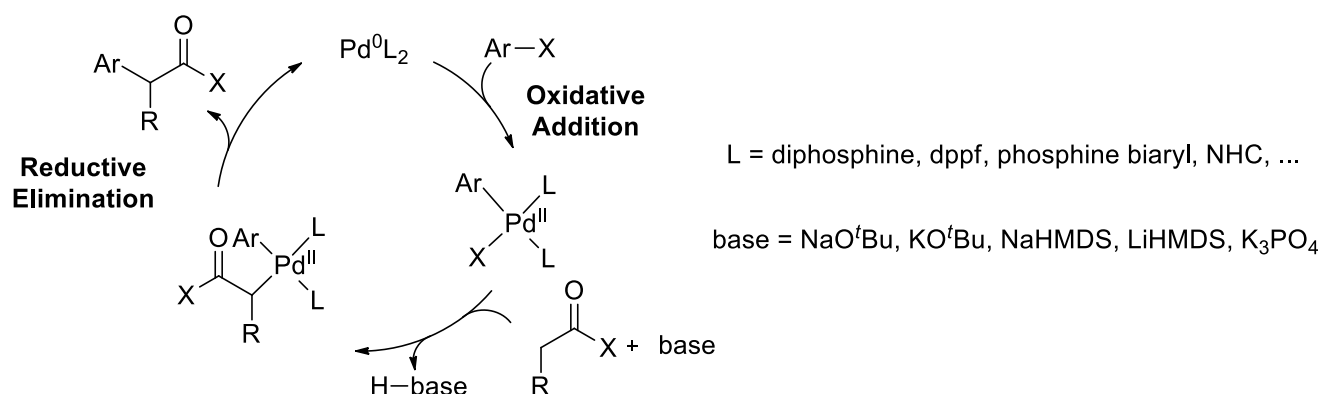

The alpha arylation of enolates cannot be done using classical substitution reactions. Cross-coupling using a Pd-catalyst works well in this case, and the enolate takes the role of the organometallic reagent in the catalytic cycle. A disadvantage of the method is the requirement of relatively strong bases. The same ligands used for more classical Suzuki cross-coupling were also successful in this case.

Early transition-metals for cross-coupling

Iron catalysts

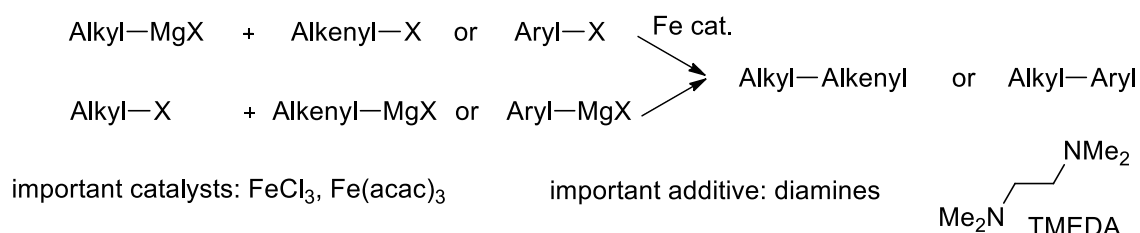

The Kumada-Corriu coupling with Grignard reagents using Pd catalysts is less often used, as transmetalation is usually slower than side reactions. Important progress has been realized with early transition-metal catalysts, which react faster with Grignard reagents. These are less expensive and also less prone to beta-hydride elimination, which make them particularly well suited for the coupling of alkyl reagents. In particular, both the coupling of alkyl Grignard reagents and alkyl halides has been realized using iron catalysts, especially under the impulsion of **Alois Fürstner** (*Acc. Chem. Res.* **2008**, *41*, 1500.). Iron(III) chloride and Iron(III) acetylacetonate are the most often used catalysts, sometimes with diamine additives, such as tetramethylethylenediamine (TMEDA). The mechanism of the Fe-catalyzed cross-coupling is still under investigation and is more complex than with palladium.

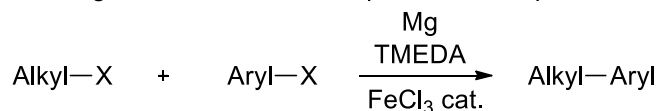

An interesting modification was recently reported by von Wangelin (*Angew. Chem., Int. Ed.* **2009**, *48*, 413.), starting directly from an alkyl and an aryl halide. The cross-coupling product is obtained with magnesium powder and an iron catalyst in the presence of TMEDA.

Nickel catalysts

Use of ethers

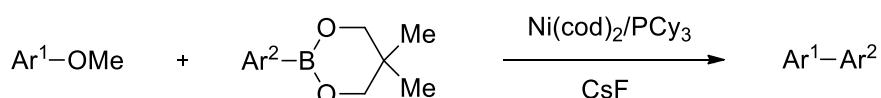

Alkyl-alkyl and alkyl-aryl cross coupling

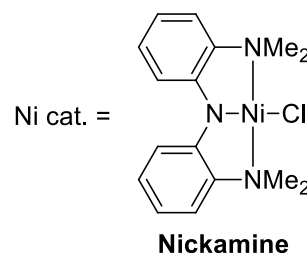
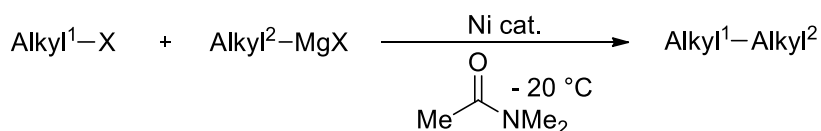

Nickel catalysts have been useful in several cases. They allowed the use of much less reactive aryl ethers as electrophiles (although the scope is still limited, *Angew. Chem., Int. Ed.* **2008**, *47*, 4866.). Ni Pincer catalysts, e.g. Nickamine by Hu allow for cross-couplings of alkyl halides, both with alkyl and aryl Grignards.

7.1.3 Sonogashira cross-coupling

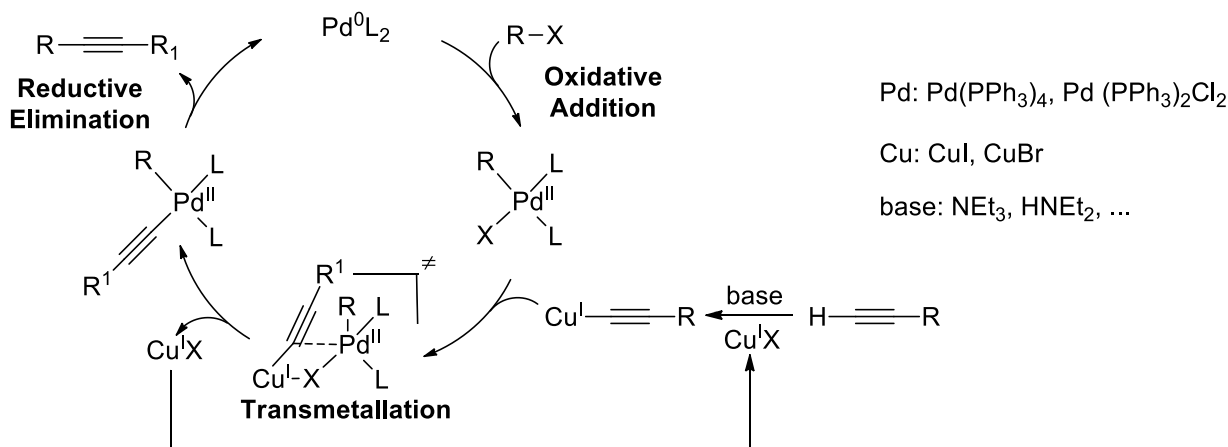

The Sonogashira cross-coupling occurs between acetylenes and aryl or vinyl halides. The high acidity of the C-H bond of acetylenes allows the formation of the organocopper reagent under catalytic conditions. The classical conditions for the Sonogashira reaction are a Pd catalyst with triphenylphosphine, triethylamine and copper iodide. Nevertheless, the yield can be improved in difficult cases by the use of one of the new ligands developed for cross-coupling reactions, which we have seen before. Current research in the reaction tries to go to a single catalyst system, either palladium or copper.

7.1.4 Heck Coupling

Classical Heck

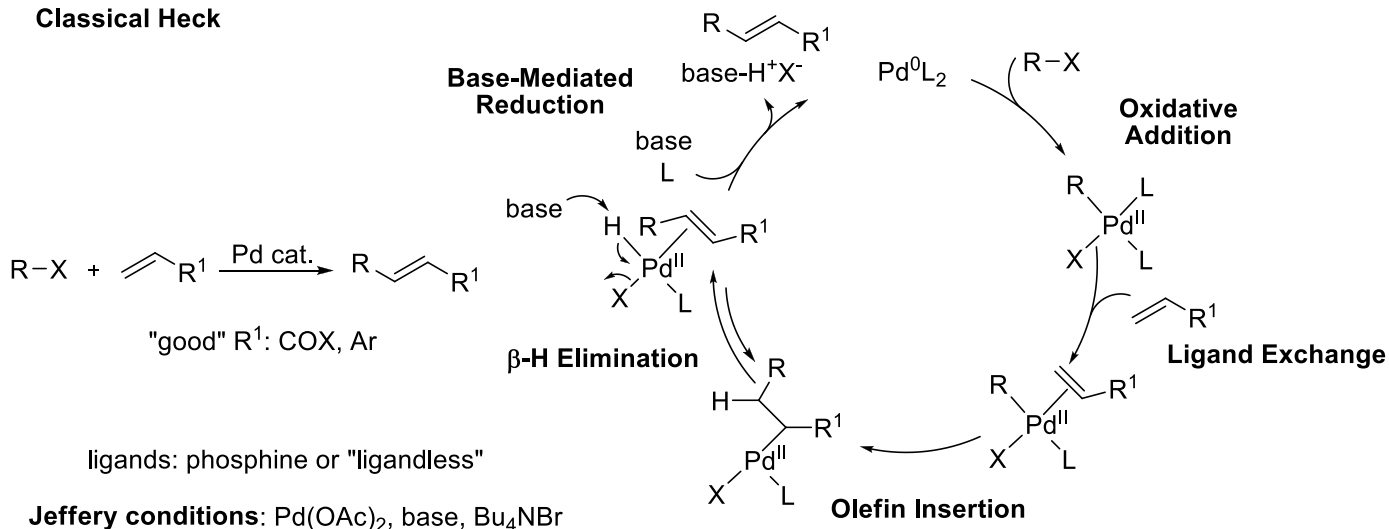

The Heck coupling is formally the cross-coupling between a vinyl C-H bond and a C-X bond. In reality, the reaction proceeds via oxidative addition, ligand exchange and olefin insertion. The last step is a beta-hydride elimination, which can lead to a mixture of products if several beta hydrogens are present. Depending on the leaving group, the reaction can proceed either via neutral or cationic Pd complexes, which changes the reactivity and selectivity of the process. The reaction works especially well intramolecularly, and for specific intermolecular cases (unsaturated carbonyl compounds, styrenes). The best ligands are often phosphines, but in certain cases ligandless conditions can give better yields, in particular the **Jeffery conditions** with an excess of halogen ions.

Oxidative Heck

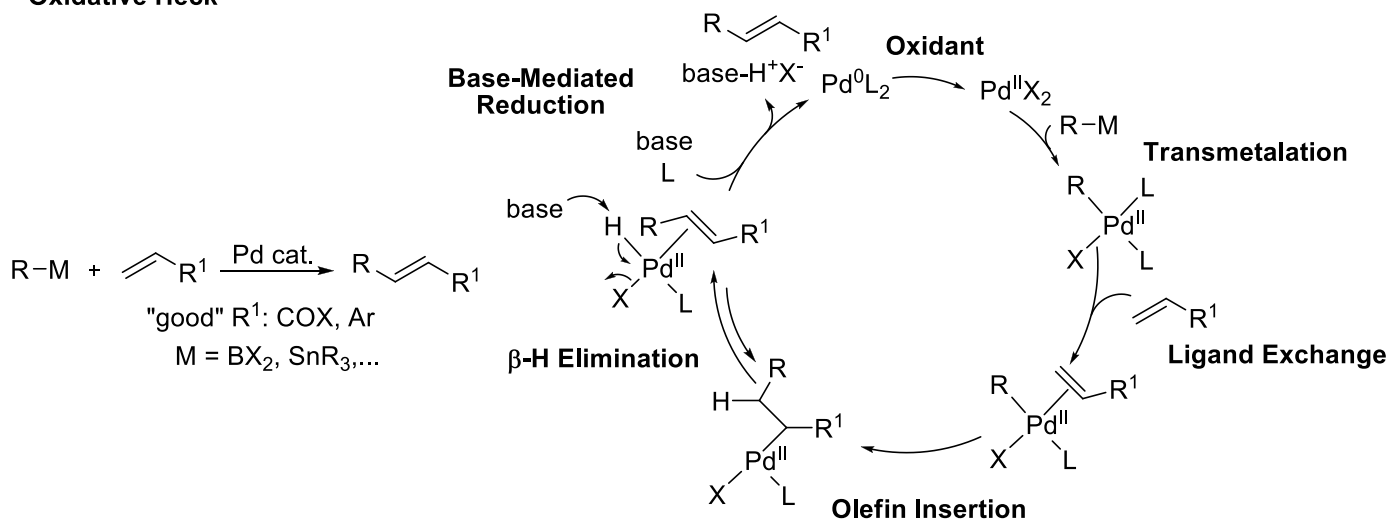

The oxidative Heck reaction allows the coupling of organometallic reagents, often organoboron reagents, with olefins. In this case, the reaction starts with transmetalation on a Pd(II) complex. After olefin insertion and beta-hydride elimination, the formed Pd(0) is re-oxidized with an external oxidant (often a copper salt, oxygen or a quinone) to close the catalytic cycles.

7.1.5 C-X coupling

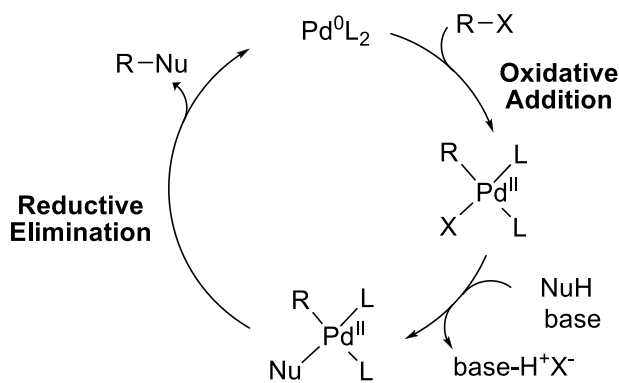
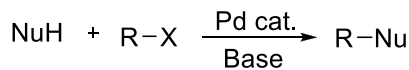

Most successful ligands for amines (**Buchwald-Hartwig amination**)

Hartwig

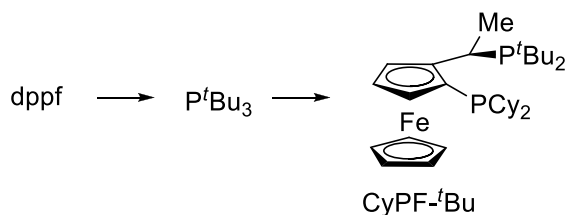

Buchwald

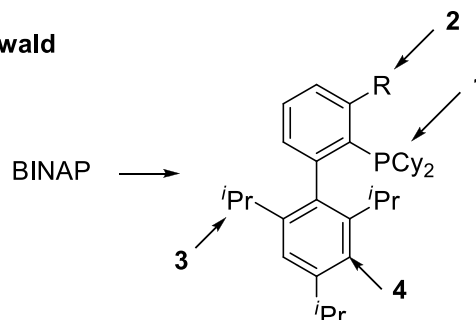

The introduction of heteroatoms onto aromatic rings is essential for medicinal chemistry and the pharmaceutical industry. The development of cross-couplings with heteroatoms was especially difficult, as amines, alcohols or thiols are often also good ligands for metal and can saturate the active sites of the catalyst. In particular, the development of Pd catalyzed aminations of aryl halide by **Buchwald** (*Angew. Chem., Int. Ed.* **2008**, *47*, 6338.) and **Hartwig** (*Acc. Chem. Res.* **2008**, *41*, 1534.) was an important progress (**Buchwald-Hartwig amination**). Hartwig first used biphosphine ligands such as dppf. He then found that tri-*tert*-butyl phosphine was a better ligand. Finally, the best ligand in his case were bulky biphosphines derived from ferrocene (Josiphos type ligands). Buchwald was initially working with BINAP, and then discovered the biaryl monophosphines as exceptional ligands. In this case, the substituent on phosphine (**1**) has to be an alkyl (more electron-rich, faster oxidative addition) and bulky (faster reductive elimination, only one ligand on Pd). The substituent on the upper aryl ring (**2**) can fix the conformation and accelerate the reductive elimination. The large substituent on the lower aryl ring (**3**) prevents side-reaction with the Pd center (cyclometalation) and promotes mono-ligation. Finally, the second aryl ring (**4**) stabilizes the phosphine towards oxidation, stabilizes the Pd center via secondary interaction and promotes reductive elimination.

Cu catalyzed C-X bond formation

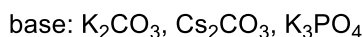
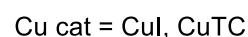
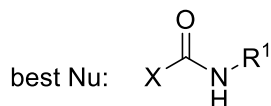
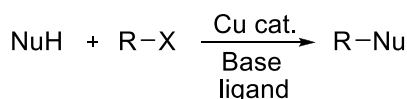

best ligands:

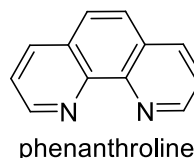
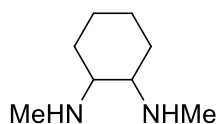
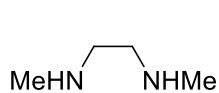

amino acids

Copper catalysts are a cheaper alternative when compared to palladium. They are especially successful for the coupling of less nucleophilic amines, such as amides. The ligands were essential to develop mild catalytic conditions. The best ligands are diamines, phenanthroline and amino acids. The bases are usually inorganic salts and the copper catalyst copper iodide or copper thiophenecarboxylate (CuTC). The method also works for etherification reactions.

7.2 Metathesis

alkene metathesis

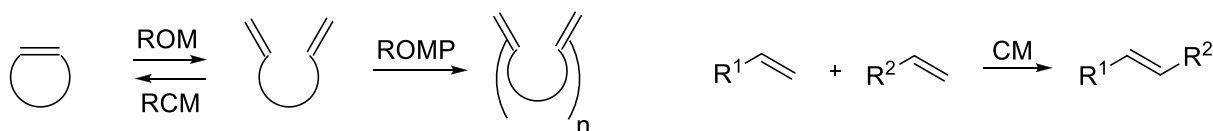

Catalysts:

Schrock: Mo

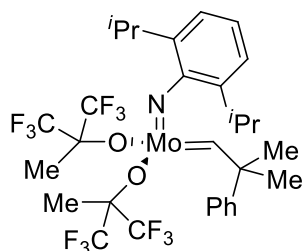

Grubbs: Ru

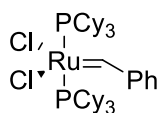

1st generation

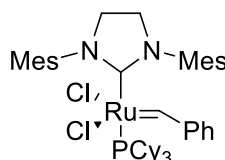

2nd generation

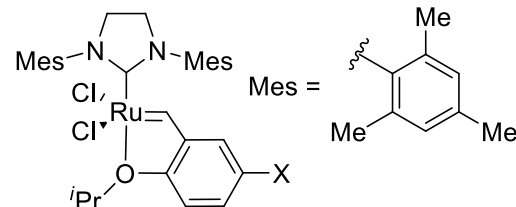

Hoveyda (-Blechert)-Grubbs

X = NO₂, Grela modification

Olefin synthesis has completely changed the way organic chemists synthesize alkenes. The most important processes are ring-opening metathesis (ROM), ring-opening metathesis polymerization (ROMP), ring-closing metathesis (RCM) and cross-metathesis (CM). The Mo catalysts developed by Schrock are very reactive, but sensitive and not tolerant to all functional groups. The Ru catalysts introduced by Grubbs are more tolerant. The first generation were based on phosphine ligands, whereas the second generation includes NHC ligands. This process is described in details in inorganic chemistry.

alkyne metathesis

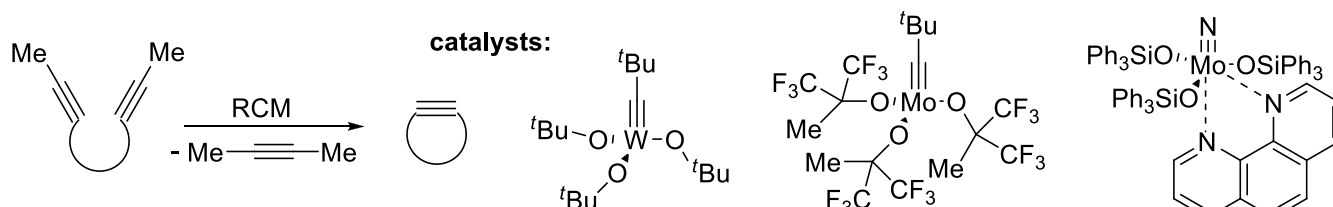

Alkyne metathesis has been less developed than alkene metathesis. It works best with very sensitive Mo or W catalysts. In contrast to olefin metathesis, it doesn't work with terminal alkynes. The advantage of ring-closing alkyne metathesis is that there are no issues of *E/Z* selectivity, which is still a major weakness of olefin metathesis. It is furthermore possible to reduce the triple bond selectively to the *trans* or the *cis* olefin. An interesting discovery of Fürstner is the introduction of phenanthroline-stabilized Mo-nitride complexes as pre-catalysts. These complexes are bench stable, and the active catalyst is generated by complexing the phenanthroline ligand with MnCl₂, followed by alkyne-nitride metathesis (*J. Am. Chem. Soc.* **2010**, *132*, 11045.).

7.3 Olefins and Carbonyls Functionalization

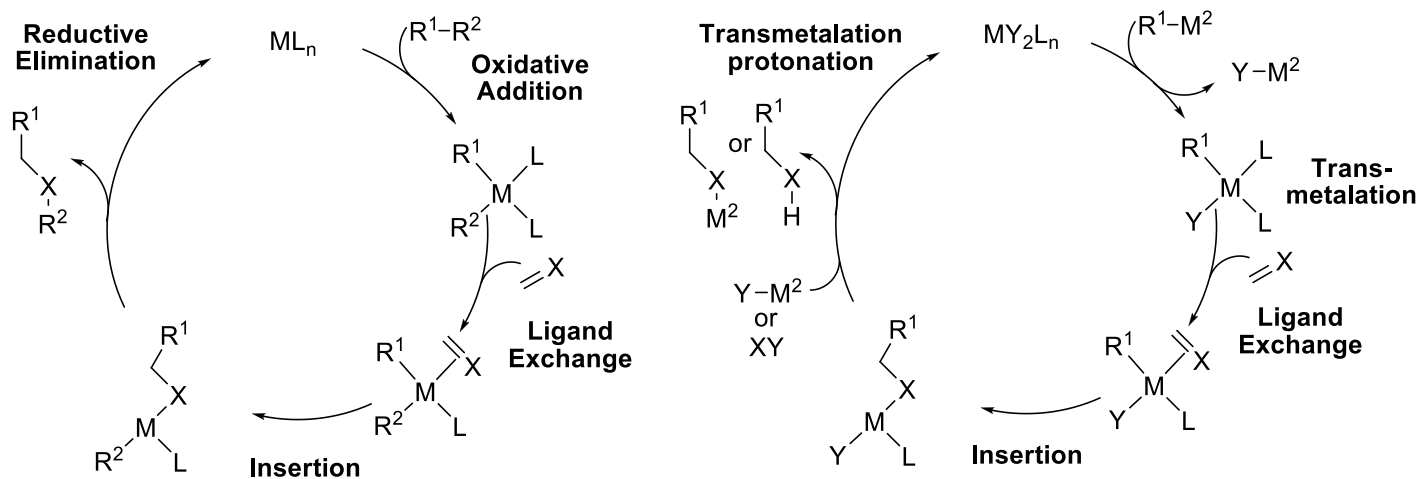

Redox active catalyst

important cases:

mostly: $X = C$, also O, N

- $R^1-R^2 = H_2$, Hydrogenation
- $= H_2$, with CO , Hydroformylation
- $= HSiR_3$, Hydrosilylation
- $= HBR_2$, Hydroboration
- $= HSnR_3$, Hydrostannylation
- $= R_2BBR_2, R_3SiSiR_3$

catalysts: Rh, Ru, Ir, Pd, Pt,....

Not Redox active catalyst

important cases

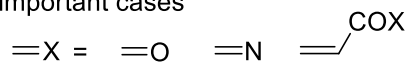

$M^2 = B, Mg, Zn, Si, Sn, Ti, Zr, \dots$

special: OM^2 $M^2 = Li, Na, K$

catalysts: Rh, Cu, ...

The functionalization of olefins, carbonyls, imines and acetylenes using transition metal catalysts is a very important field of research in modern organic chemistry. Although many of these reactions can be performed without transition metals, catalysis offers several important advantages: (1) milder conditions, which allows often broader functional groups tolerance. (2) Control over regio and stereo selectivity by modulation of the metal center and the ligands. (3) Potential for asymmetric reactions using chiral ligands. The functionalization of less polarized system is often done using a redox active catalyst. The reaction starts with an oxidative addition, followed by insertion and reductive elimination. A typical reaction is the hydrogenation of olefins. With more polar substrates, the reaction can proceed without oxidation/reduction of the metal center. The active metal nucleophile is generated via transmetalation, and the catalytic cycle is closed by protonation or transmetalation. Particular important reactions are the additions of organometallic reagents to carbonyls or conjugate additions. As these types of reactions are very important for the development of asymmetric methods, they will be seen in details in the course catalytic asymmetric reactions in organic synthesis.

7.3.1 Nozaki-Hiyama-Kishi Coupling

Original procedure

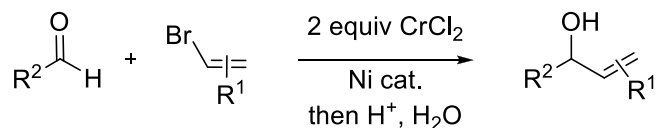

Catalytic in chromium (Fürstner)

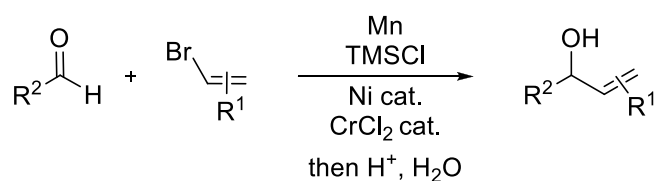

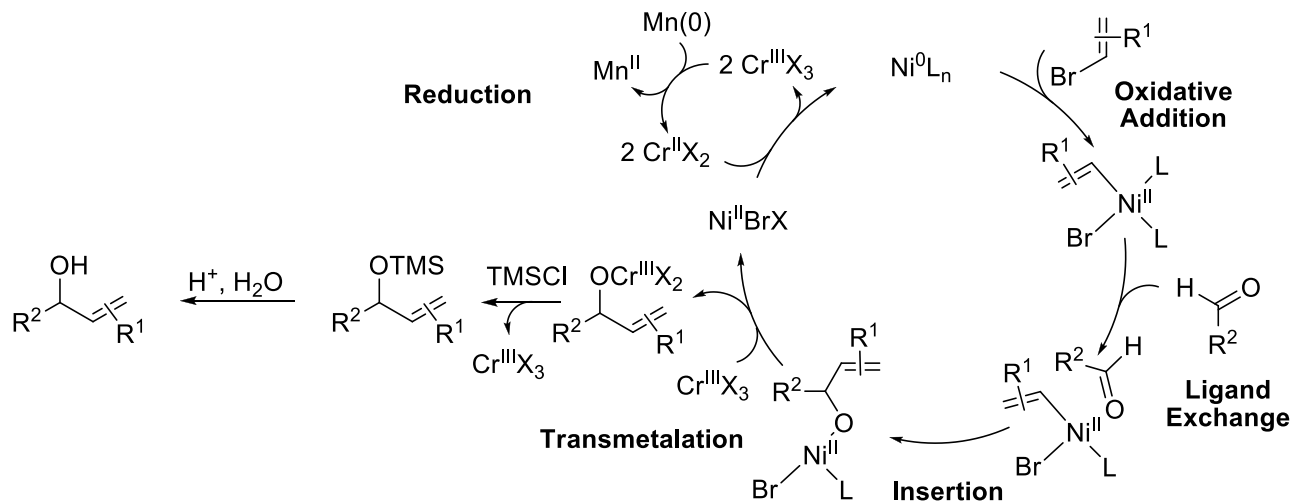

The Nozaki-Hiyama-Kishi coupling is a very mild method for the synthesis of allylic alcohols starting from vinyl halides and aldehydes, as it does not involve basic organometallic reagents such as Grignards. For this reason, it has been used successfully in many total syntheses. The mechanism is more complex than other classical reactions with carbonyl compounds. After oxidative addition and insertion, the nickel alkoxide formed is transmetalated to chromium. The Ni(II) salt is then reduced by two equivalents of chromium(II) salt. In the original method, a large amount of toxic and sensitive chromium(II) was required. Fürstner then introduced Mn powder as a stoichiometric reductant. For the catalytic reaction to be efficient, it is necessary to break the chromium alkoxide formed at the end of the reaction using trimethylsilyl chloride. The reaction also works for allyl halides, but in this case more methods are existing.

7.3.2 Allylic Alkylation

Direct reaction

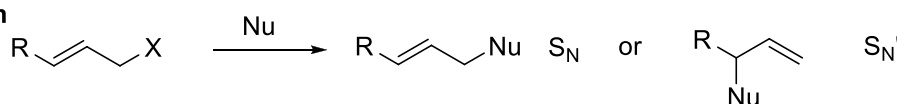

Electrophilic activation

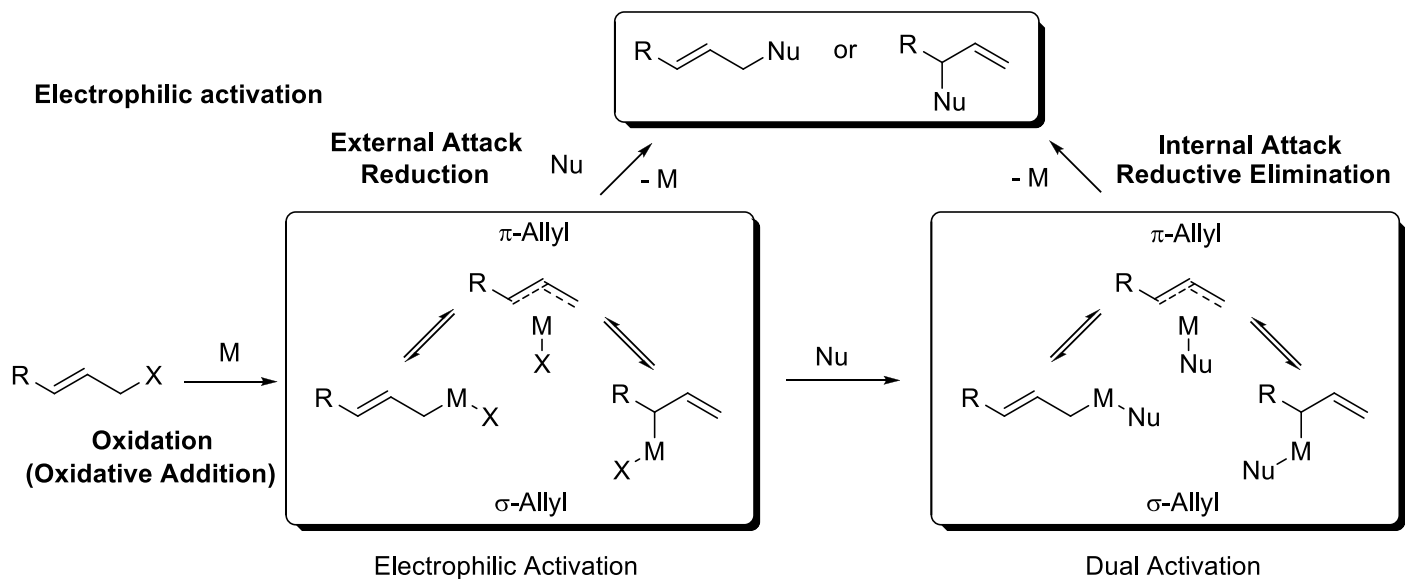

Nucleophilic activation

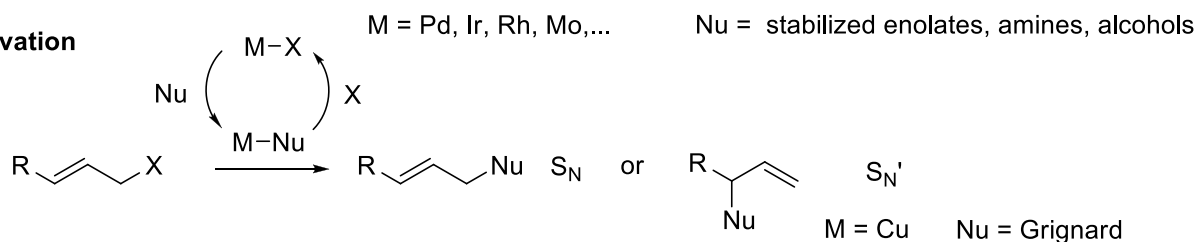

The metal catalyzed alkylation using allylic electrophiles is one of the most powerful methods in organic chemistry. The direct reaction, the S_N1 substitution, is possible, but difficult to control. The most frequent method uses the activation of the allylic system with a metal catalyst via oxidative addition (the most common one is palladium). Either a sigma or a pi allylic complex can be formed with the metal. At this point, an external attack of a nucleophile can take place to generate the product and reduce the metal. Alternatively, the nucleophile can first bind to the metal, and the product is then formed through a reductive elimination. By the choice of metal and ligands, it is possible to control the mechanism and the regioselectivity of the reaction, and many chiral ligands have been developed for this process (see lecture catalytic asymmetric reactions in organic synthesis). Alternatively, activation of the nucleophile by the metal (usually copper) can be used.

7.4 Catalytic C-H Functionalization

Bibliography: Yu, J. Q.; Shi, Z. *Top. Curr. Chem.* **2010**, Vol. 292.

7.4.1 General Mechanisms

A biomimetic approach?

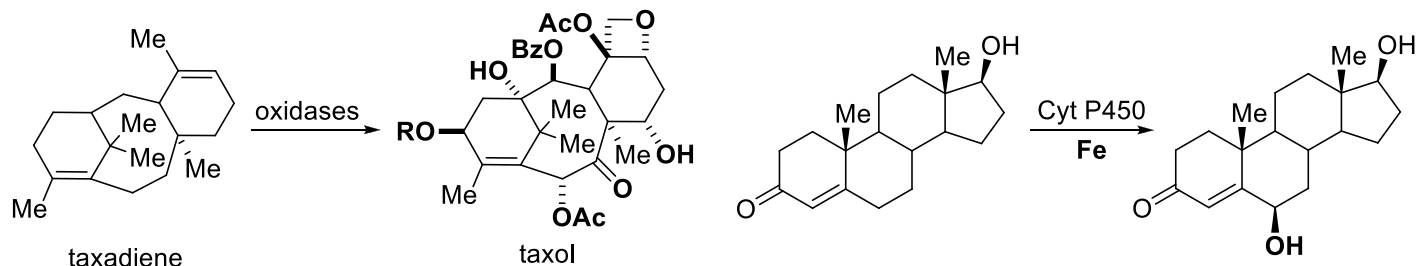

To introduce functional groups, organic chemists usually use pre-functionalized building blocks (for example in the aldol reaction). Another approach followed by nature is the late-stage functionalization of C-H bonds. This approach has several advantages: less steps, less waste generated, no problem of functional group compatibility in the early stage of synthesis. For chemists, there are challenges in reactivity and selectivity: there are usually many C-H bonds in organic molecules, and the C-H bond is strong and difficult to break. The classical way to do that is by radical H abstraction (see chapter 5), but stoichiometric reagents are usually required in this case. For these reasons, catalytic C-H functionalization is still not a routine method in organic chemistry, but it is one of the most investigated reactions in fundamental research.

Some possible mechanisms

Inner sphere/metalation

A/ oxidative addition

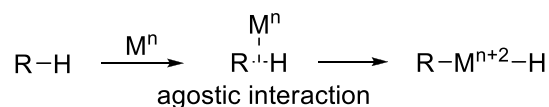

B/ sigma bond metathesis

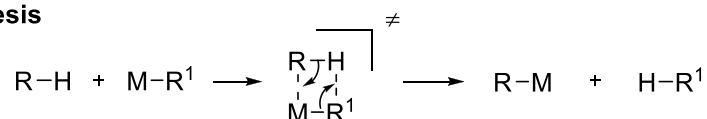

C/ sigma-pi bond metathesis

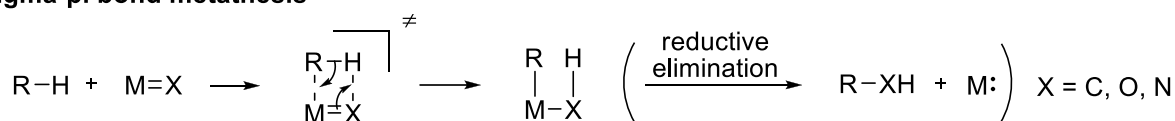

D/ CDM (Concerted Deprotonation Metalation)

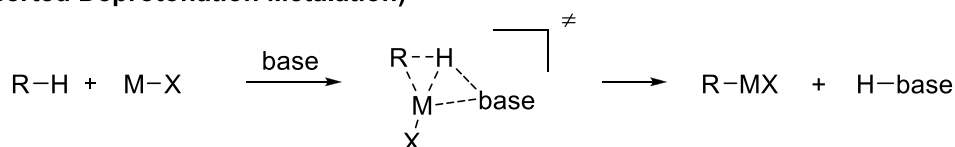

E/ Deprotonation-Metalation

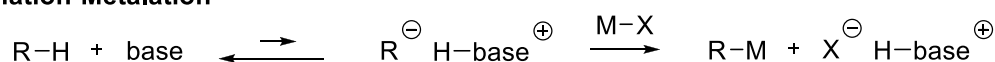

F/ Radical Recombination

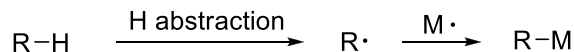

G/ Electrophilic Metalation (For SP² only)

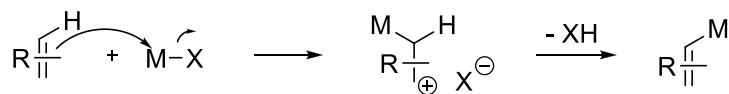

The methods for catalytic C-H functionalization can be roughly separated into inner sphere/metalation, in which a metal-C bond is formed, and outer sphere, in which no metal-C bond is formed.

For the inner sphere reaction, an organometallic reagent is generated. It is usually quite easy to find a metal to make the metalation step, or one metal which is catalytic active, but very difficult to find a metal able to do the C-H metalation, and then be catalytic active. The possible catalytic cycles are all we have seen before in this lecture. Some possible mechanisms for C-H functionalization are:

A/ Oxidative addition: this is a difficult process for C-H bonds, which proceeds better when intramolecularly. It is important that the metal center has a strong interaction with the C-H bond (agostic interaction).

B/ Sigma bond metathesis: The metathesis with sigma bond is much more difficult than for alkenes.

C/ Sigma-pi bond metathesis: The reaction of metal carbenoid (or nitrenoid, oxo) can also occur. One classical follow up reaction is a reductive elimination. This mechanism is less easy than for two olefins, and alternative outer sphere mechanisms are sometimes more favored (H, I)

D/ CDM (Concerted Deprotonation Metalation): The CDM mechanism has proven to be favored in many cases. The best bases for this process are the one able to act as a base and coordinate the metal at the same time, typically carboxylates.

E/ Deprotonation/metalation: This process is interesting, when a weak base is enough to promote the metalation, which ensures broad functional group tolerance. The use of a stoichiometric amount of strong base (BuLi) followed by transmetalation has already been seen for cross-coupling reactions.

F/ Radical recombination: In principal, radical intermediates can be recombined with high spin metal complexes. This method is less useful, as stoichiometric radical abstraction reagents are usually required.

G/ Electrophilic metalation: In the case of olefins and arenes, a possible mechanism is first the reaction of the pi system with an electrophilic metal to generate a carbocationic intermediate. After elimination, the organometallic reagent is formed and can enter the catalytic cycle. An exogenous base can be added to accelerate the reaction.

Outer Sphere/No M-C bond formed

H/ Concerted Insertion

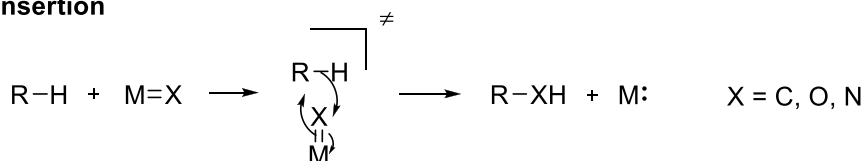

I/ Radical Rebound

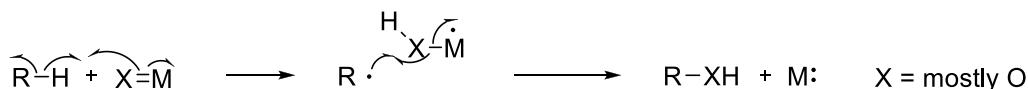

J/ Oxidative Dehydrogenation

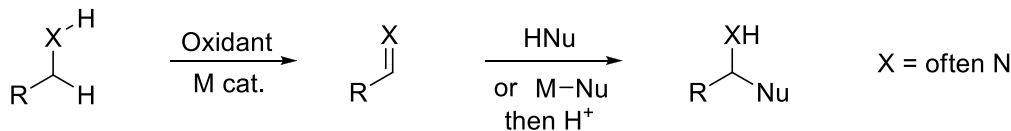

K/ Electrophilic activation (only for SP²)

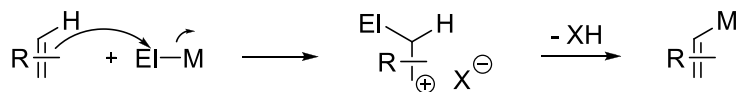

In the outer sphere mechanisms, no C-M bond is formed, and direct functionalization is observed. A few possible mechanisms are:

H/ Concerted insertion: This mechanism is similar to the cyclopropanation of olefins with carbenes. It has been very successful for the insertion of carbon into C-H bonds, especially intramolecularly.

I/ Radical rebound: The mechanism is very close to the concerted insertion, but occurs stepwise. Stepwise processes are more probable for oxygen insertion. This mechanism has also been proposed for enzyme-catalyzed oxidation reactions.

J/ Oxidative dehydrogenation: many catalysts and reagents are able to dehydrogenate C-H bonds, especially in alpha position to an heteroatom. If the dehydrogenation step can be combined with the addition of a nucleophile (metal-activated or not) onto the olefin, an overall C-H functionalization is achieved.

K/ Electrophilic activation: In the case of olefins or arenes, many catalysts are able to activate electrophiles for addition (classical Friedel-Craft reactions). The result is formally also a C-H functionalization, although reactions proceeding following this mechanism are often considered separately.

As there are many different possibilities, it is often difficult to determine the exact mechanism of C-H functionalization reactions. The term C-H activation should be used only for the case in which the metal is involved directly in the breaking of the C-H bond (mechanisms **A-D**).

7.4.2 Synthetically important examples

7.4.2.1 C-H borylation

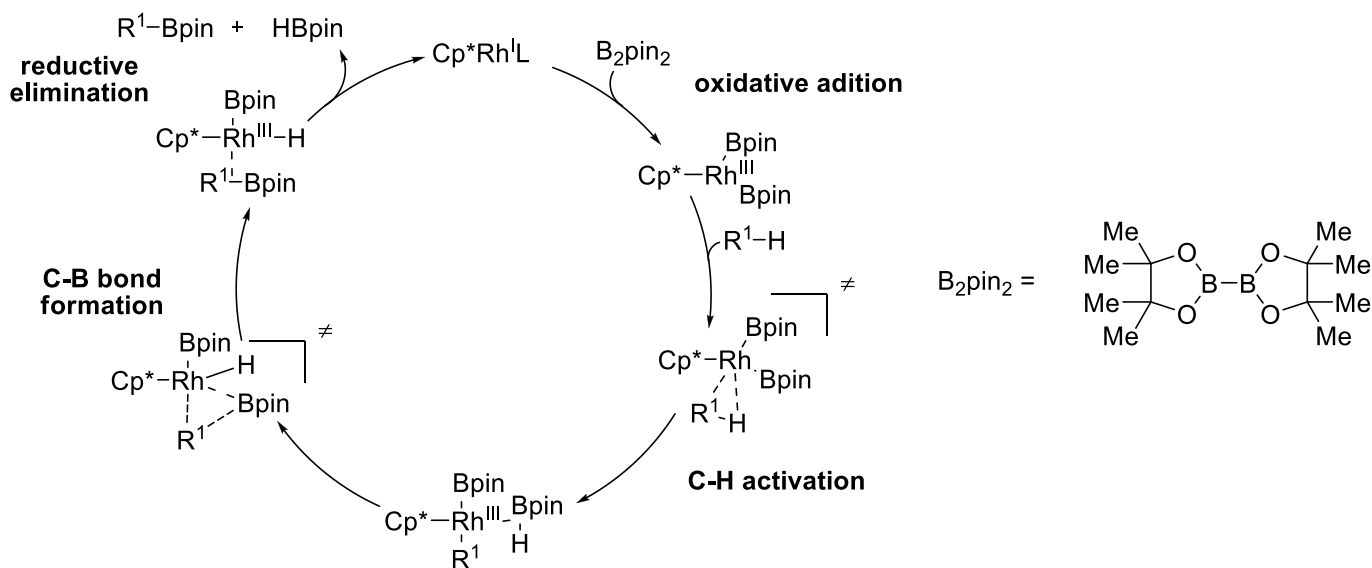
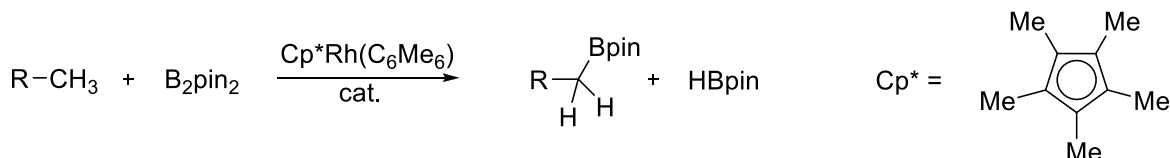

Boranes are versatile compounds in organic chemistry, either as precursors of alcohols or in cross-coupling reactions. The rhodium-catalyzed borylation of C-H bonds developed first by **Hartwig** works both for SP² and SP³ C-H bonds (*Science*, **2000**, 287, 1995. *Chem. Rev.* **2010**, 110, 890). Mechanistically, the C-H functionalization reaction has been proposed to go via "partial oxidative addition", as the transition state looks like for an oxidative addition, but a B or H atom is transferred without formation of an oxidated intermediate (Mix of mechanism **A** and **B**). The other steps of the catalytic cycle are oxidative addition on the B-B bond and reductive elimination of HBpin.

7.4.2.2 Directed Pd-catalyzed functionalization of benzene C-H bonds

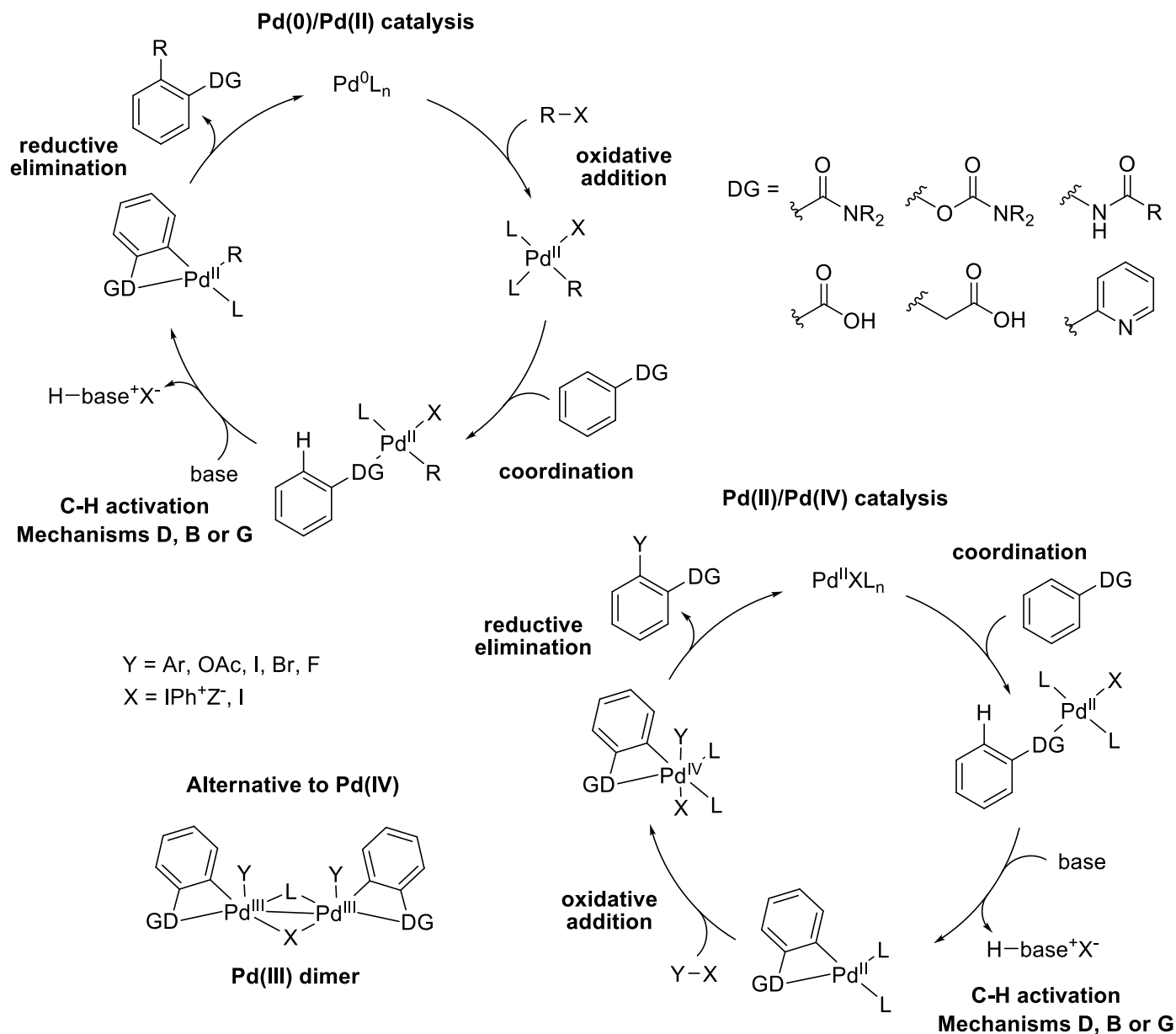

The Pd-catalyzed functionalization of benzene C-H bond directed by coordinating groups can work either via a Pd(0)/Pd(II) or via a Pd(II)/Pd(IV) mechanism. In the first case, the reaction is especially good for C-C bond formation to make biaryls. In the second case, the high reactivity of Pd(IV) allows unusual reductive elimination reactions to make also C-X bonds. The exact nature of the reactive Pd intermediate is still matter of some debate, and the reaction could also proceed via Pd(III) dimers. The oxidation to Pd(IV) usually requires stronger oxidants, and the best are usually hypervalent iodine reagents. The research in this field has been driven by **Melanie Sanford** (*Chem. Rev.* **2010**, 110, 1147.). An important part of research is the extension of the coordinating groups that can be used. The first reactions were developed for amides and pyridines, but recent results (especially by **Jin-Quan Yu**) allow the use of more versatile functional groups such as acids. The mechanism for C-H activation is most probably a concerted deprotonation metalation mechanism (**D**), although sigma bond metathesis (**B**) or electrophilic metalation (**G**) could also be considered. In some cases, Rh and Ru catalysts have also been successful.

7.4.2.3 Directed Pd-catalyzed functionalization of SP³ C-H bonds

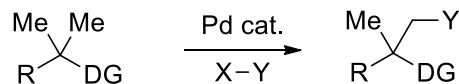

The direct functionalization of aliphatic C-H bonds proceeds via the same mechanisms than for benzene C-H bonds, but the C-H activation step is more difficult. Consequently, only pioneering results have been obtained and this field is currently one of the "hot field" of research.

7.4.2.4 Pd-catalyzed functionalization of heteroaromatic and acidic C-H bonds

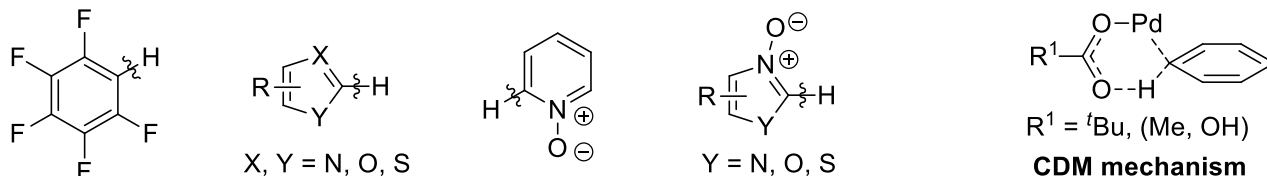

In the case where acidifying groups or heteroatoms are present, the formation of the Pd-intermediate is possible without a directing group. This method is particularly important for the functionalization of heterocycles, such as indoles, pyrroles, thiophenes, imidazoles, oxazoles, thiazoles and pyridines. Except for the initial coordination step, the catalytic cycle is similar to that for the functionalization of benzene C-H bonds. The activation of the C-H bond proceeds via concerted metalation deprotonation (CDM, **D**) or deprotonation/metalation (**E**) for acidic bonds, and probably via electrophilic metalation (**G**) for electron-rich heterocycles, such as indoles. The oxidation of electron-poor nitrogen heterocycles to the corresponding *N*-oxide was found by **Keith Fagnou** to increase greatly the reactivity of the C-H bond, which allows directly the functionalization of pyridines. For the CDM mechanism, carboxylate bases are best, as they allow a 6-membered transition state. The best conversion is often observed with pivalate. In certain cases, the Pd catalyst can be replaced by a copper or a nickel catalyst.

7.4.2.5 Pd-catalyzed functionalization of allylic C-H bonds

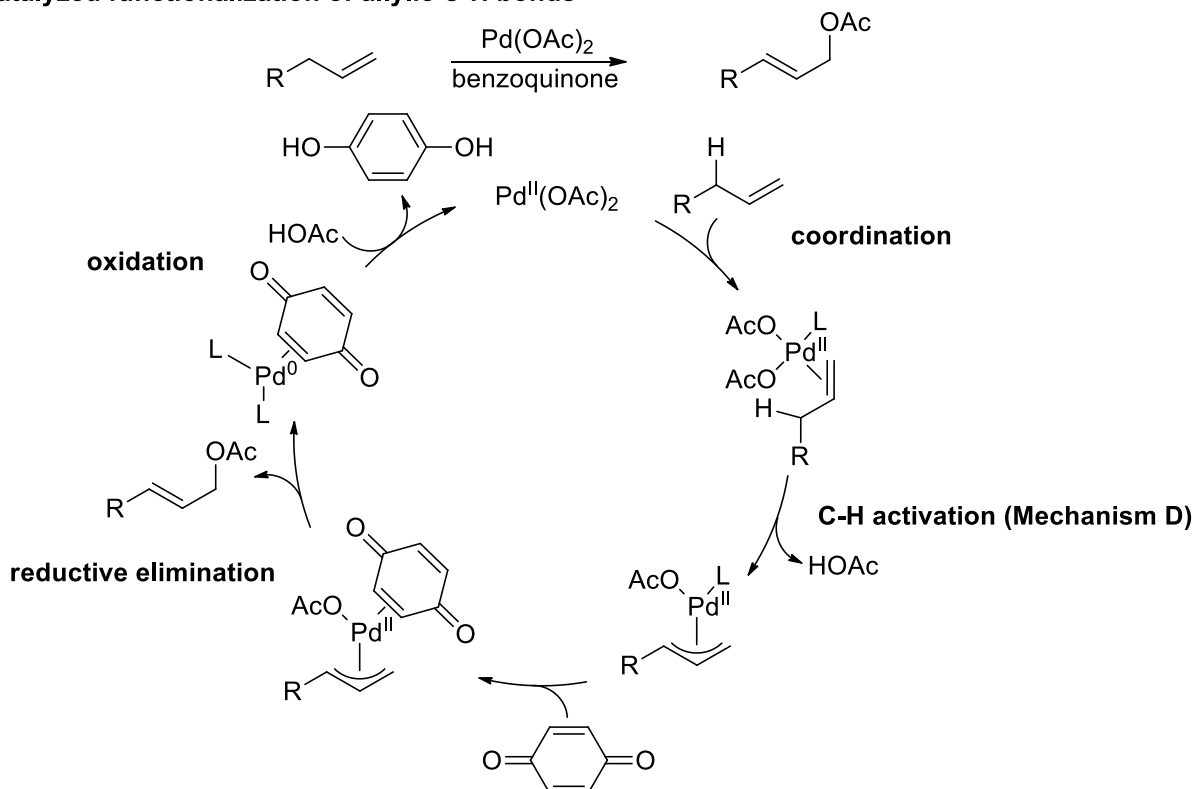

The palladium-catalyzed oxidation of allylic C-H bonds is a synthetic method, which was improved recently by **Christina White**. The coordination of the olefin to palladium facilitates the C-H activation via internal deprotonation. The oxidant benzoquinone was also found to play a key role as a ligand, as it is essential to promote an otherwise difficult reductive elimination to form the C-O bond. The last step of the catalytic cycle is oxidation of the Pd(0) back to Pd(II) by the quinone. Recently, the reaction has been extended to other nucleophiles.

7.4.2.6 Catellani (norbornene) method

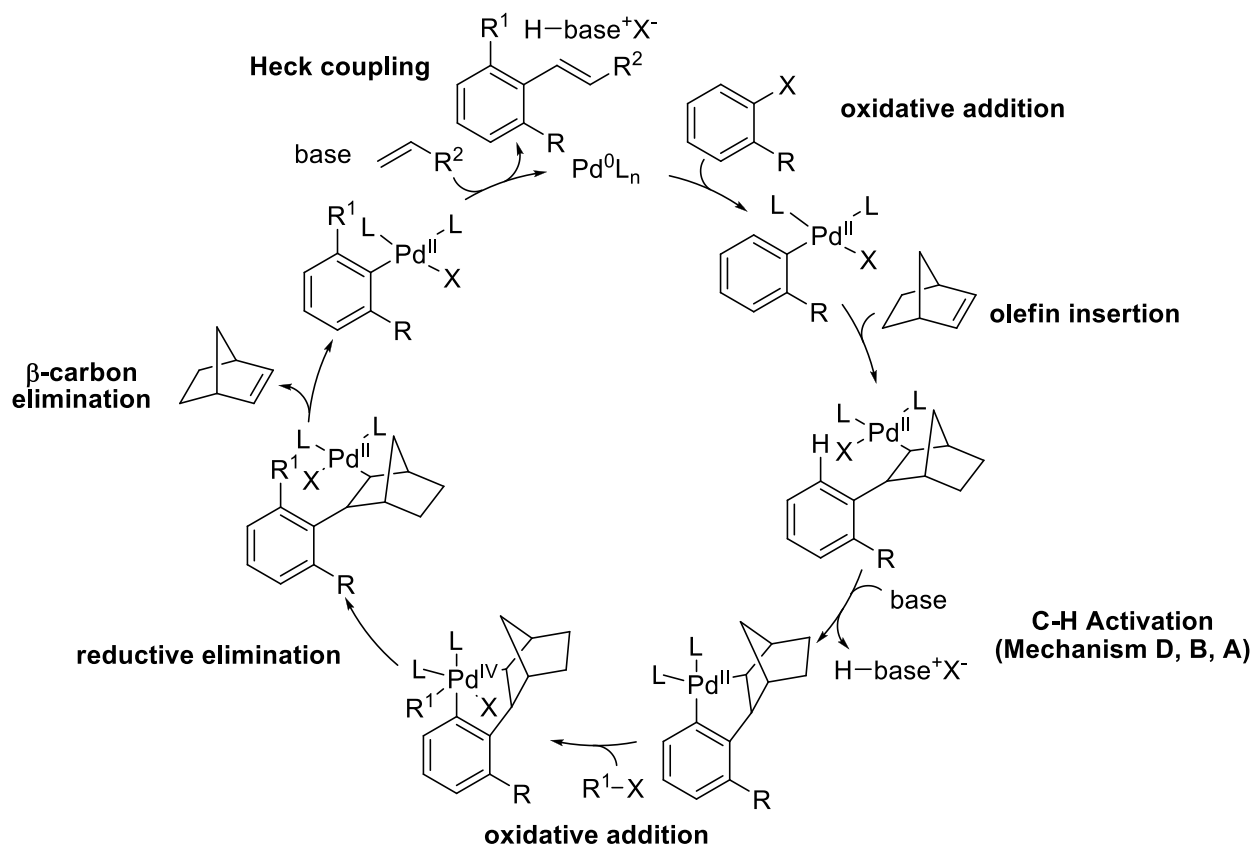

The Catellani method using norbornene as co-catalyst allows the C-H functionalization in *ortho* position to halide groups. The reaction starts with classical oxidative addition on the C-X bond, followed by insertion of norbornene. In the presence of a base, an intramolecular C-H activation is now possible to form a palladacycle. As both substituents are alkyl groups, the Pd center is rich in electrons, which allows oxidative addition with a second aryl halide to form a Pd(IV) intermediate. After beta-carbon elimination of norbornene, a Pd(II) intermediate is obtained, which can be used in classical cross-coupling reactions, for example a Heck reaction to regenerate Pd(0). In a single step, both C-X and C-H functionalization are achieved in this process.

7.4.2.7 Oxidative Heck coupling

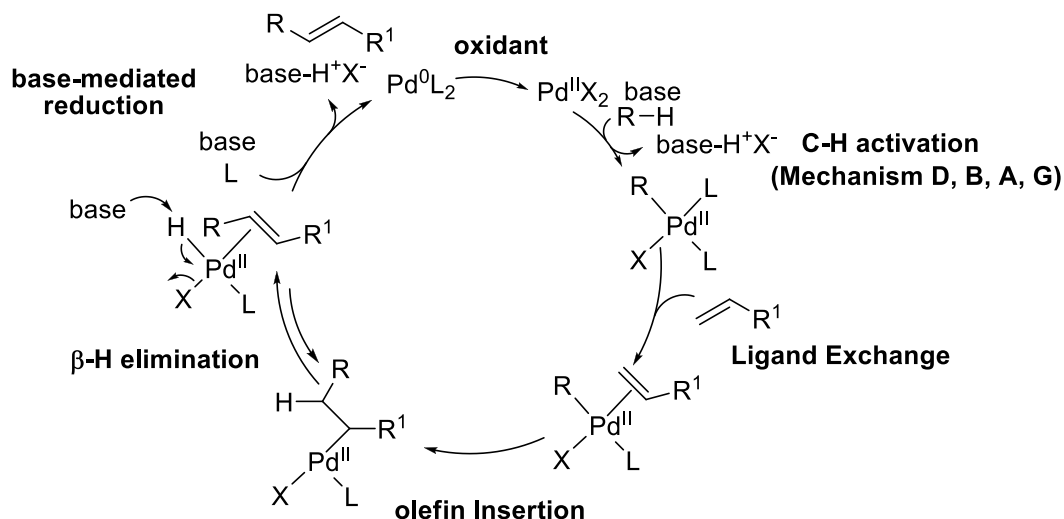

In the oxidative Heck coupling, C-H activation is followed by insertion and beta hydride elimination. At the end, the Pd catalyst need to be re-oxidized. The reaction has been successful both using directing groups or more acidic C-H bonds. The oxidant is usually copper salts, silver salts or oxygen. If oxygen can be used as oxidant, the reaction is nearly ideal as neither metal nor salt wastes are generated during the process (it is a formal C-H/C-H coupling).

7.4.2.8 C-H/C-H coupling

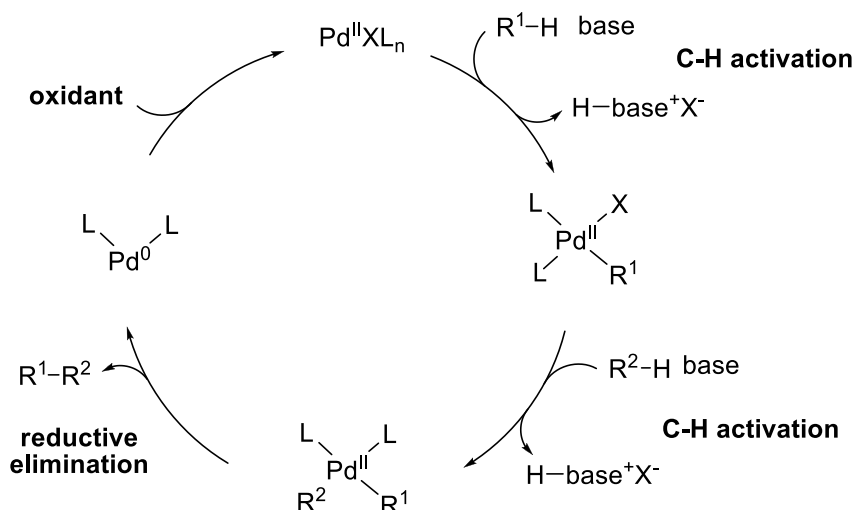

In principle, the direct C-H/C-H functionalization is the "ideal reaction" as no pre-functionalization of the partners are required. Each step of C-H activation can be done using the principles seen before. Nevertheless, it is difficult to do two challenging C-H activations in a single catalytic step, and it is very difficult to prevent homocoupling (two times activation of R¹-H to form the homo-dimer). Consequently, the reaction is already highly useful for homo-coupling, but further research is required in the case of heterocoupling.

7.4.2.9 Oxidative coupling in alpha position to heteroatoms

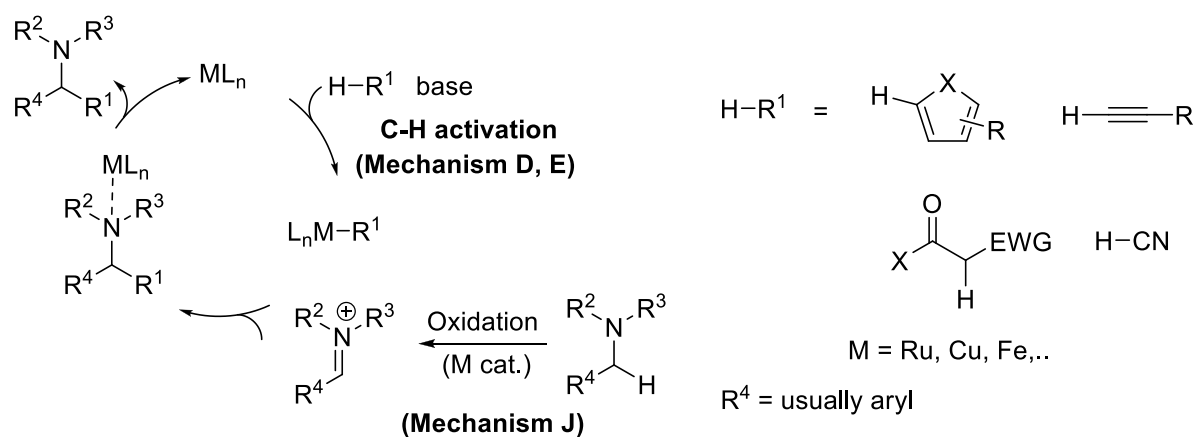

Another interesting approach to direct C-H/C-H coupling is possible in alpha position to heteroatoms, especially nitrogen. This class of substrates is easily oxidized to the corresponding iminium, which can react with an organometallic intermediate formed via C-H activation. As acidic C-H bonds are usually used, there is also a possibility of direct nucleophilic attack on the iminium, without involvement of the metal. The metal can also be involved in the oxidation step, which makes the exact mechanism of this reaction difficult to determine. Best catalysts are often copper and iron, and in this case single electron transfer (SET) mechanisms have to be considered.

7.4.2.10 Carbene, nitrene and oxo C-H insertion



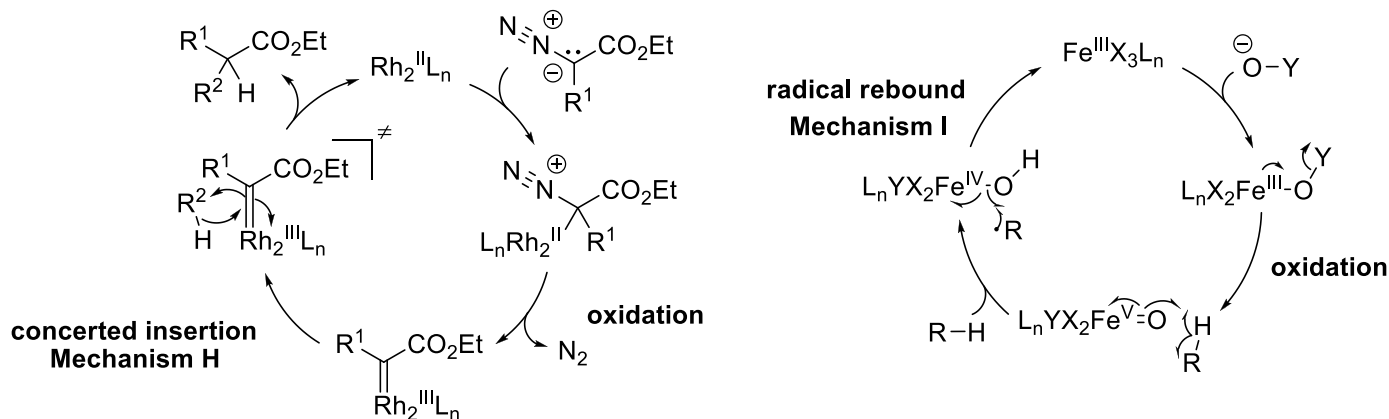

Important oxidants:

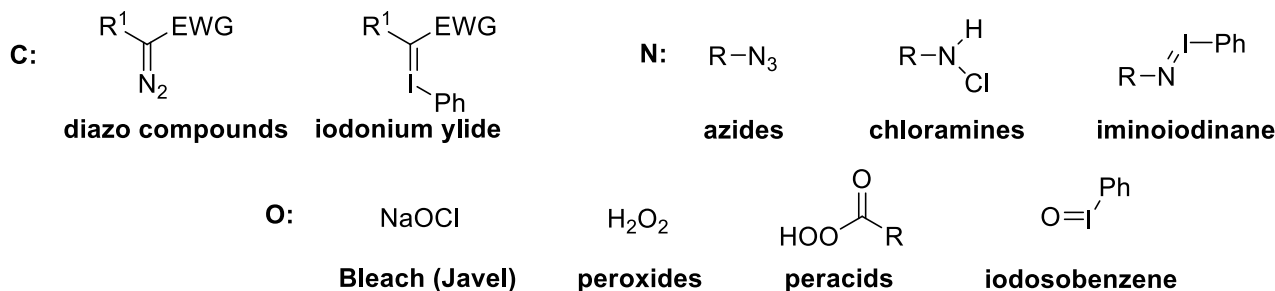

The insertion of carbene-like intermediates is an important method for the functionalization of C-H bonds, which usually proceeds via outer sphere mechanism. In the first step, the metal is oxidized to form the reactive carbene, nitrene or oxo intermediate. C-H bond functionalization can then be either concerted, mostly for carbene insertion using rhodium catalysts, or stepwise via a radical rebound mechanism, especially for iron catalysts and oxygen transfer. The carbene insertion reaction is especially useful intramolecularly, and the exact structure of the diazo compound and the ligand on rhodium are important to increase the efficiency of insertion compared to other carbene involving reactions (see section 4.4.3). The oxygenation reaction with iron also occurs in enzymes and efficient synthetic systems were developed especially by **Christina White**. The Iron oxo complex is highly electron-deficient and the most electron-rich C-H bond is oxidized (tertiary C-H > secondary C-H > primary C-H).

7.5 Synthesis of carbocyclic and heterocyclic systems using metal catalysts

7.5.1 Annulation (cycloaddition) reactions

7.5.1.1 Dötz benzannulation

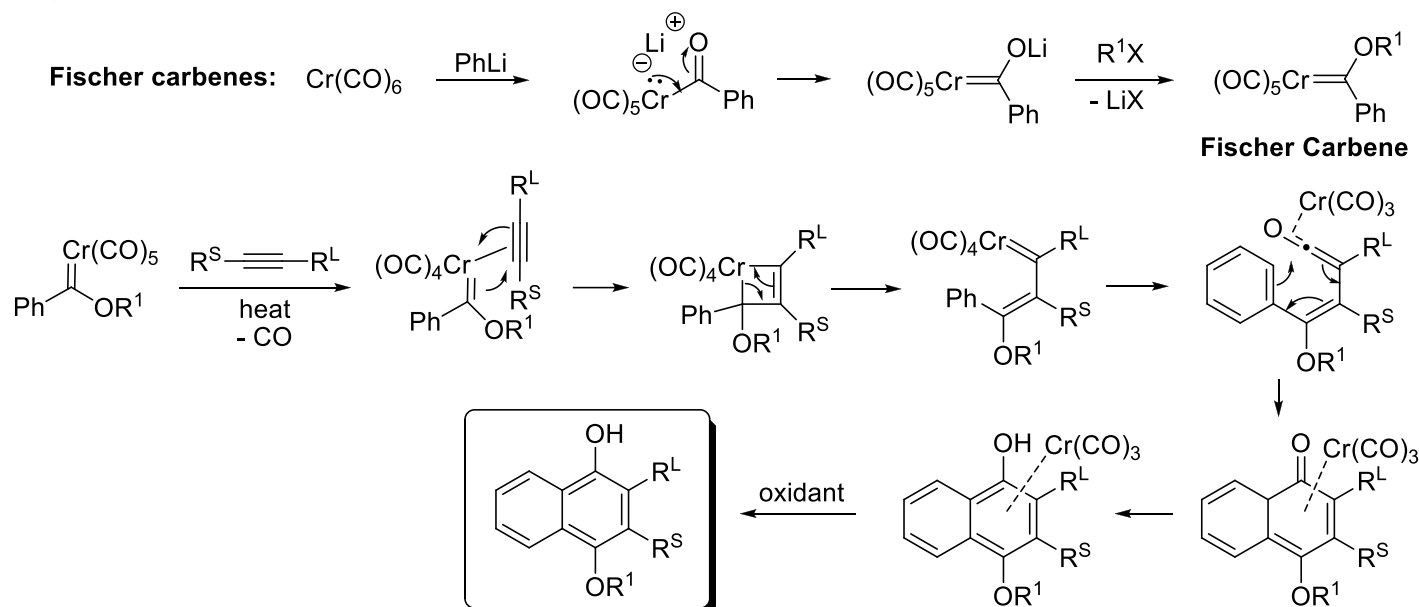

The Dötz annulation is one of the first transition metal mediated cycloaddition reaction and involves the reaction of aryl substituted **Fischer carbene** complexes with acetylenes. Fischer carbenes are obtained from the reaction of chromium hexacarbonyl with an organolithium reagent, followed by quenching with an alkyl electrophile. The annulation proceeds via two pi bonds metathesis, followed by CO insertion. Electrocyclization then gives a cyclohexadienone, which tautomerizes to the more stable phenol. Chromium can be removed from the product via oxidation. The Dötz reaction represented an important progress in the understanding of metal-mediated annulation reactions, but the requirement for stoichiometric chromium has limited its use.

7.5.1.2 "Trimerization" of acetylenes and alkenes

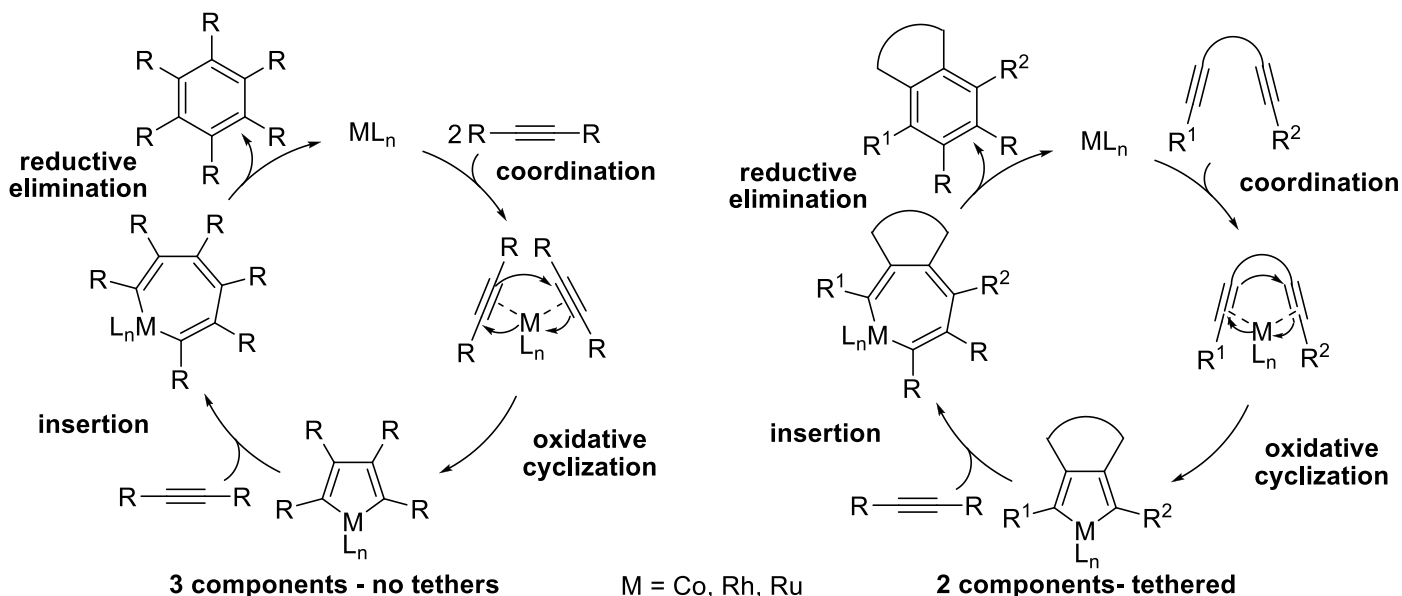

The metal-catalyzed trimerization of acetylenes is an important method for the synthesis of benzene rings. The reaction proceeds via acetylene coordination, oxidative cyclization, insertion of acetylene and reductive elimination. It is very difficult to control the regioselectivity of the reaction if different substituents are on the acetylenes. In this case, it is useful to use a two components approach, in which two acetylenes are covalently linked. Due to the chelate effect, coordination to the diyne will be more efficient, and oxidative cyclization will occur on this substrate. After insertion and reductive elimination, highly substituted benzene rings are obtained. In some case, the regioselectivity can also be controlled with two different substituents on the acetylene, playing on steric and electronic effects on substrates and ligands. The first reactions were developed using cobalt catalysts, but rhodium has been especially successful more recently.

Variations:

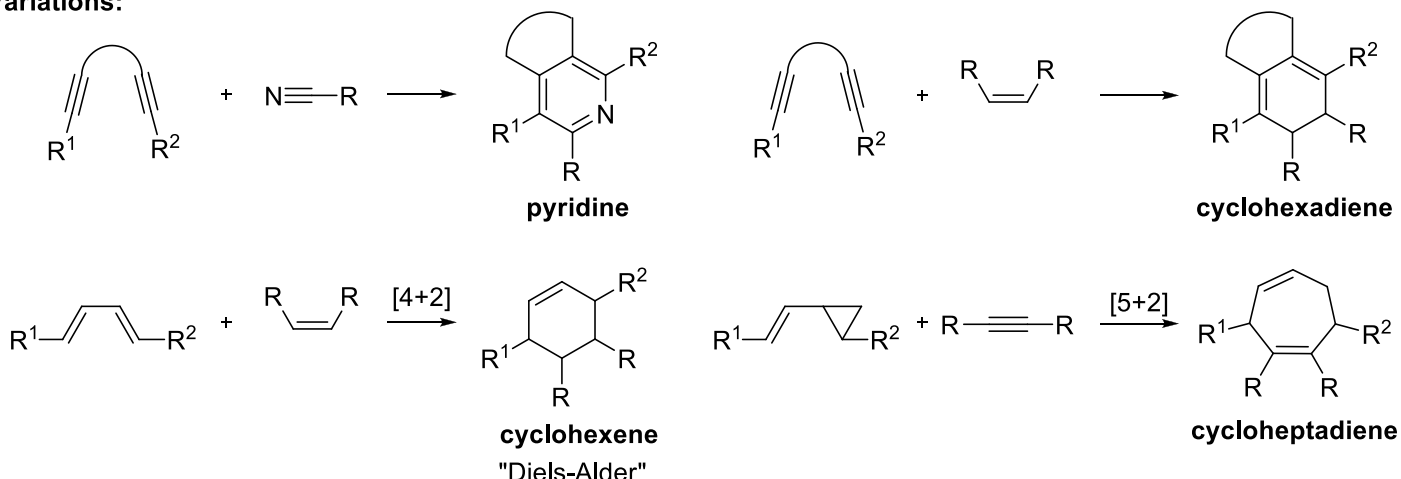

Based on the same mechanism, a very large number of processes can be designed. For example, replacement of one acetylene with a nitrile gives access to pyridines and with an alkene to cyclohexadienes. It is also possible to use a diene instead of the tethered diyne, and in the case of the reaction with an alkene, the reaction is a formal Diels-Alder reaction, but proceeds via a complete different mechanism, at lower temperature and with other selectivities. Finally, it is also possible to replace an olefin with a cyclopropane to obtain the homologous reaction.

7.5.1.3 Pauson-Khand reaction

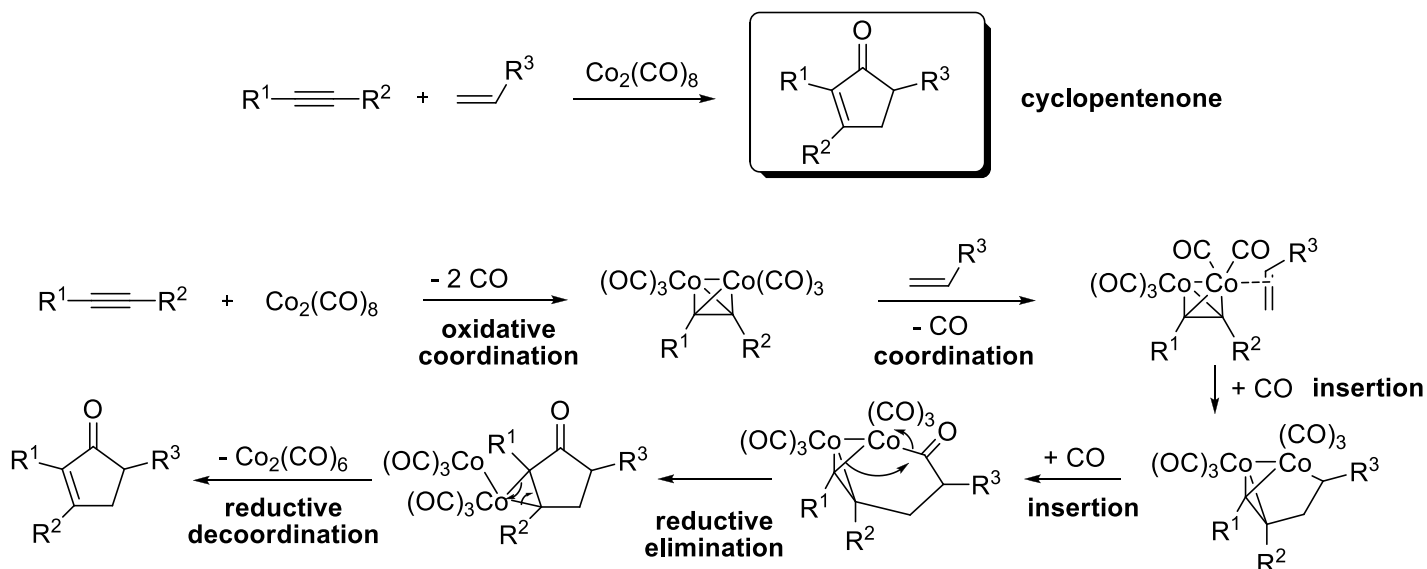

The Pauson-Khand is an important method for the synthesis of cyclopentenones starting from an alkyne, an alkene and CO (from stoichiometric cobalt octacarbonyl or CO gas). The original method started with the oxidative coordination of cobalt octacarbonyl with an acetylene. The obtained complex can then lose one CO ligand and bind the alkene. After insertion, a cobaltocyclopentane is obtained, as in the oxidative cyclization seen before. The next step is CO insertion followed by reductive elimination. Finally, reductive decomplexation of the cobalt gives the double bond. The reaction works with catalytic amount of cobalt, but in this case a high CO pressure is required. Recently, rhodium catalysts has been introduced for the reaction. The use of CO as a one carbon compound in cycloaddition reactions has then be generalized for the synthesis of other carbo and heterocycles.

7.5.1.4 Larock indole synthesis

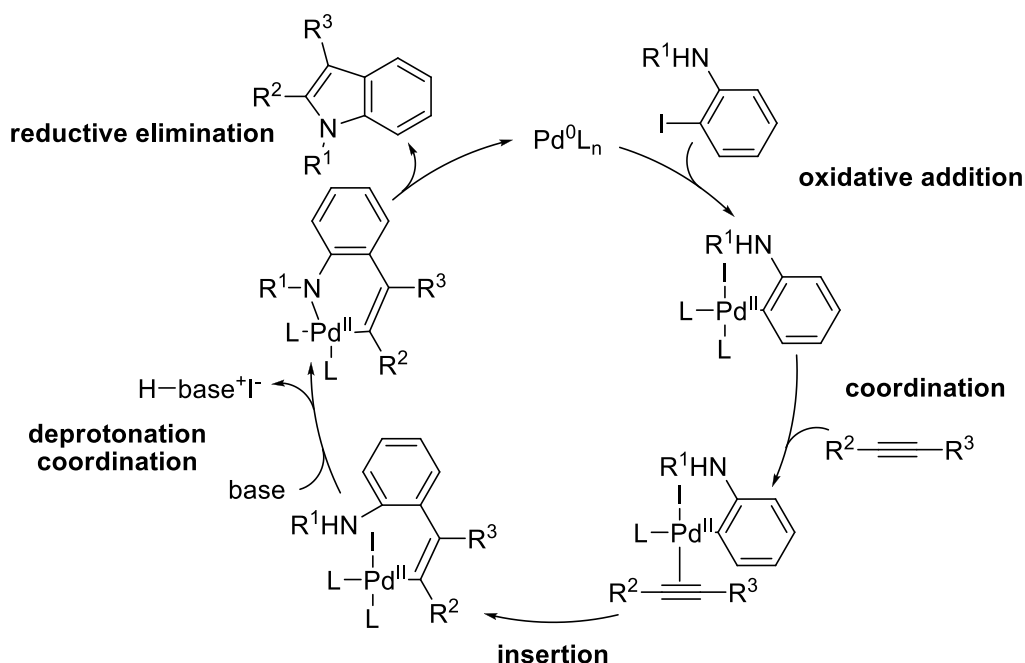

The Larock method is very useful for the synthesis of indole starting from iodo anilines and acetylenes. The mechanism is similar to the one of the Buchwald-Hartwig amination, except that there is insertion of the acetylene prior to intramolecular C-N bond formation. Similar approaches can be used for the synthesis of other heterocycles.

7.5.2 Cyclization Reactions

7.5.2.1 Wacker-type cyclization

Wacker oxidation

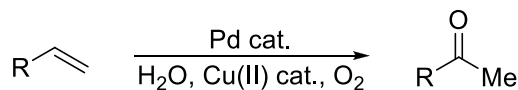

Wacker Cyclization

Y = O, NR, CREWG

R² = OAc, NR₂, ≡-SiⁱPr₃

Z = IOAcPh,

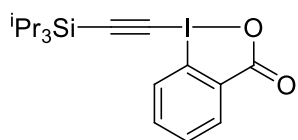
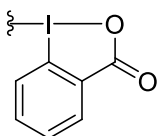

TIPS-EBX

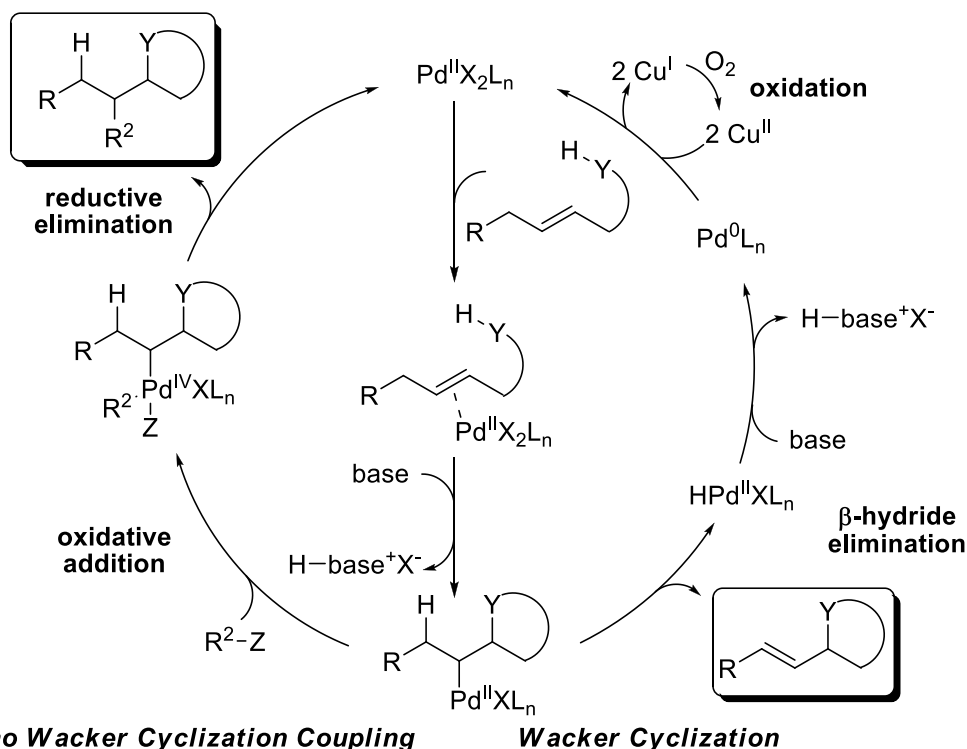

The Wacker reaction is the classical oxidation of olefins to ketons in the presence of a palladium and a copper catalyst with oxygen. The reaction is also possible intramolecularly (Wacker cyclization), but in this case the tautomerization to the ketone cannot occur. The first step is activation of the olefin with an electrophilic Pd(II) complex, followed by attack of the nucleophile to form a Pd(II) alkyl complex. After beta hydride elimination, a palladium hydride complex is obtained, which is reduced in the presence of base. The Pd(0) complex is then reoxidized by the copper to Pd(II). The reaction can be made catalytic in copper in the presence of oxygen. A difficulty in this method is to control the regioselectivity of the beta hydride elimination.

Recently, the development of cascade/domino reactions involving several C-C or C-X bond formations in a single process has become an intensive field of research in organic chemistry, as it allows to decrease the number of steps. In the case of the Wacker cyclization, the palladium alkyl intermediate can be intercepted with strong oxidants (typically hypervalent iodine), and this has been successful for the introduction of oxygen and nitrogen heteroatoms. Recently, the introduction of acetylenes was developed in the group of J. Waser at EPFL using TIPS-EBX as reagent.

7.5.2.2 Ene-Yne cycloisomerization reactions

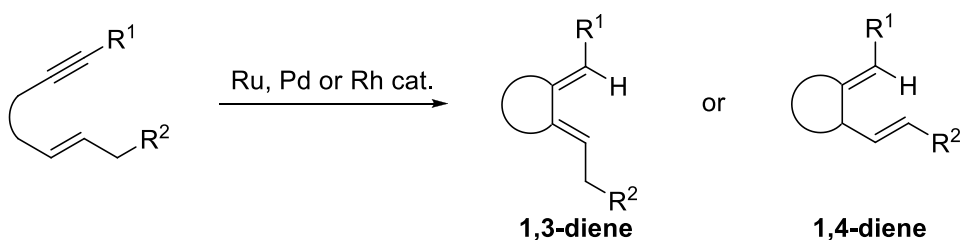

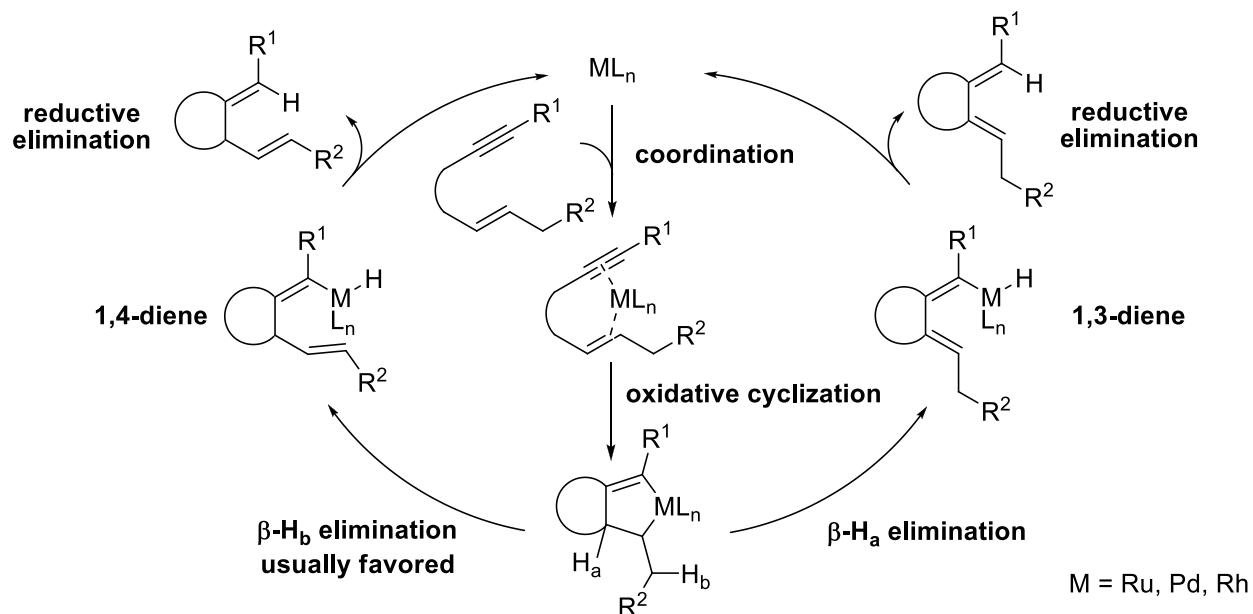

The cycloisomerization of enynes is another useful cyclization method. Ruthenium, palladium and rhodium are all able to catalyze this process, and for ruthenium, the intermolecular reaction is also possible. The first steps are the same as for cyclotrimerization reactions: coordination and oxidative cyclization. At this point, a beta hydride elimination takes place. As a metal-hydride interaction is required for beta hydride elimination, elimination at position H_b is favored to give a 1,4 diene after reductive elimination. The 1,3 diene is usually obtained only when no H_b is present.

7.5.2.3 Au and Pt-mediated cyclizations

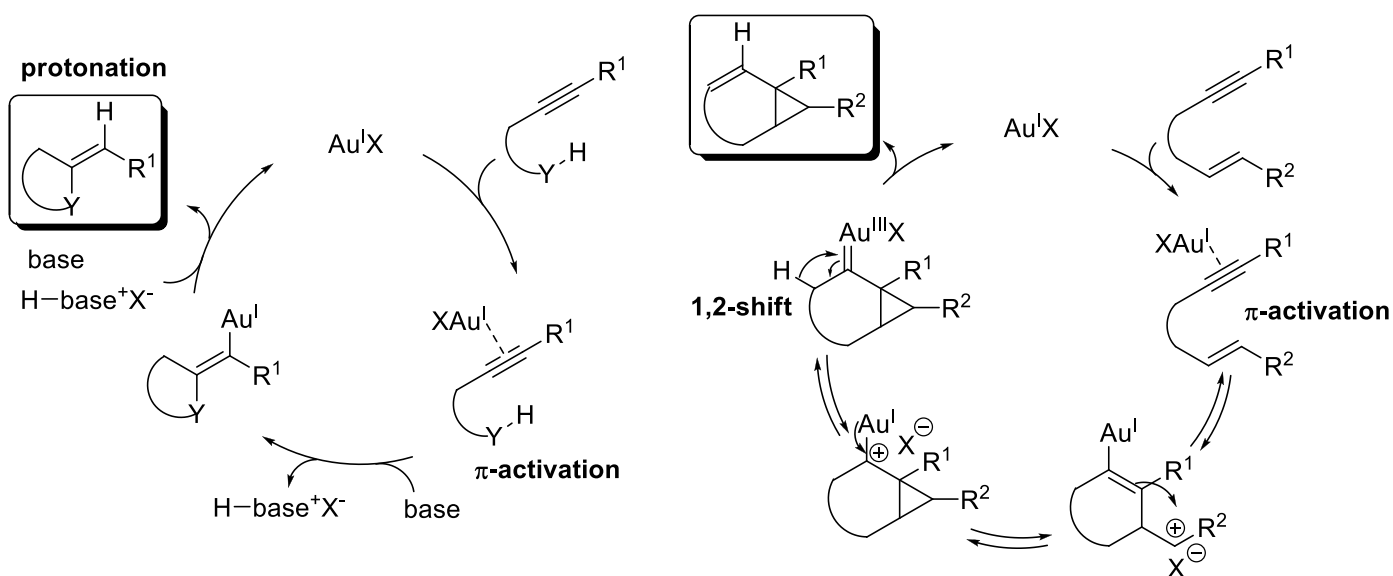

The intensive use of gold in organic chemistry is recent, as this noble metal was long considered to be not reactive enough for catalysis. In fact, redox chemistry on gold is much more difficult than on palladium, and some reactions, such as beta hydride elimination, do not occur with gold. However, gold is an exceptional Lewis acid for pi systems, especially acetylenes and is able to catalyze the intramolecular addition of heteronucleophiles on acetylenes. This can also be done with palladium, but with gold protonation of the obtained gold intermediate is easy and allows to close the catalytic cycle without the use of oxidant or beta-hydride elimination. Similar chemistry can be done with platinum.

The reaction of enynes with gold catalysts is fascinating. Intramolecular attack of the double bond on the coordinated alkyne leads to a carbocation, that can rearrange to give a gold vinylidene cyclopropane. 1,2-Hydrogen shift with loss of gold then gives a vinylcyclopropane product. During this process, shift or elimination are possible on all the carbocationic intermediates, and a very large amount of different products can be synthesized, if the result of the reaction can be controlled (Echavarren, *Chem. Rev.* **2008**, *108*, 3326.).